

15T4237

Suzuki Jimny; Md. 2018

Rear bumper 38 with mudguard
Heckrohr 38 mit Schutzblech
Tuyau arrière 38 avec garde-boue

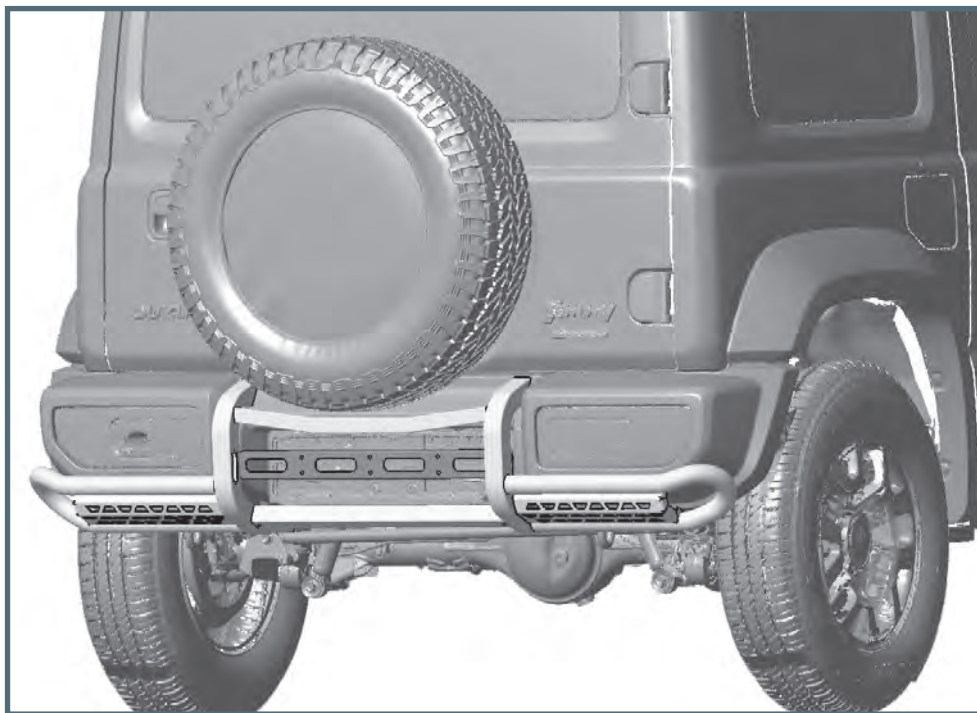

Bei Fahrzeugen mit Parksensoren hinten, kontaktieren Sie uns bitte.

For vehicles with rear parking sensors, please contact us.

ASSEMBLY INSTRUCTION

Montageanleitung • Instructions de montage

Bei Verbau mit einer Anhängerkupplung ist darauf zu achten, dass Schrauben der gleichen Güte und ausreichend langem Gewinde verwendet werden.

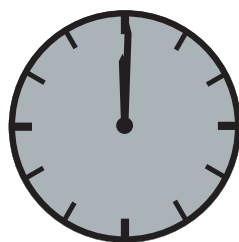

60 Minuten

When installing with a trailer hitch, ensure that bolts of the same quality and sufficiently long thread are used.

article no.:

15T4237S inox black
15T5237 steel black

Revision 4: 07.06.2022



ULLSTEIN
CONCEPTS
GMBH

M6(A2):
8,8 Nm
M8 (A2):
21,4 Nm
M10:
50 Nm
M12:
87 Nm



5T4237.1S / 15T5237

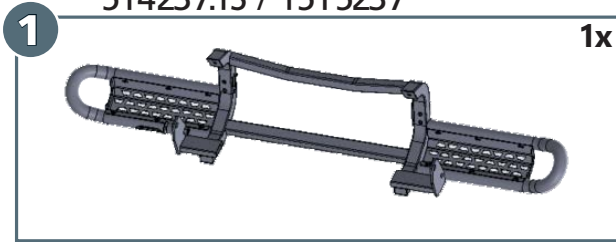

mounting kit: 15T9137

	M6x25; DIN 933 A2	4x
	M10x20; DIN 933 Zn	2x
	M12x50; DIN 933 Zn	1x
	M12x80; DIN 933 Zn	1x
	M12x1,25x40; DIN 961 Zn 10.9	4x
	M12x1,5x40; DIN 961 Zn 10.9	4x
	M12x1,25x100; DIN 960 Zn 10.9	1x
	M12x1,25x125; DIN 960 Zn 10.9	1x
	M4x10; ISO 7380 A2	4x
	M8; DIN 934 A2	2x
	M10; DIN 934 Zn	4x
	M12x1,25; DIN 934 Zn 10.9	2x
	Ø6,4; DIN 125 A2	4x
	Ø10,5; DIN 9021 Zn	6x
	Ø13; DIN 9021 Zn	10x
	GM Anschlagpuffer A2	2x
	Membrantülle 12,5mm Essentra 19433	2x

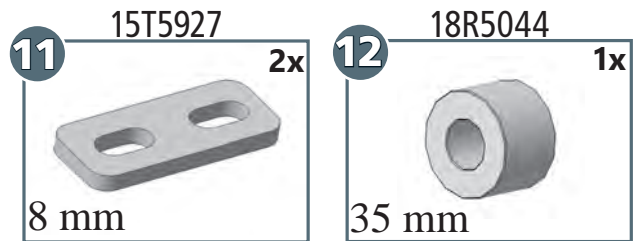
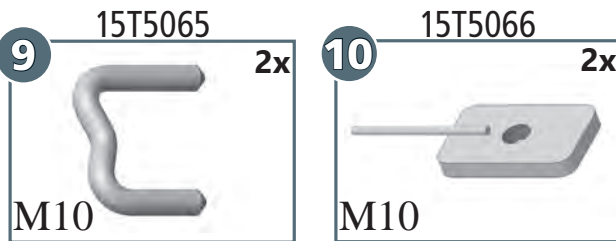
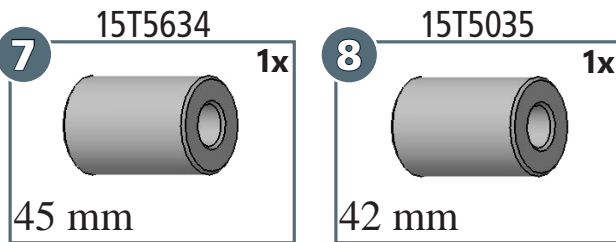
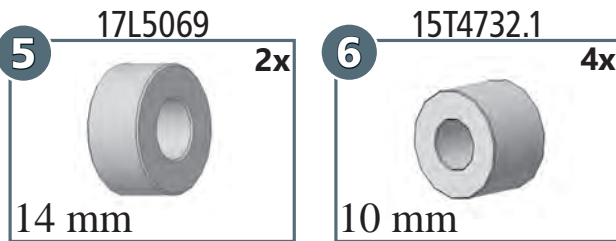
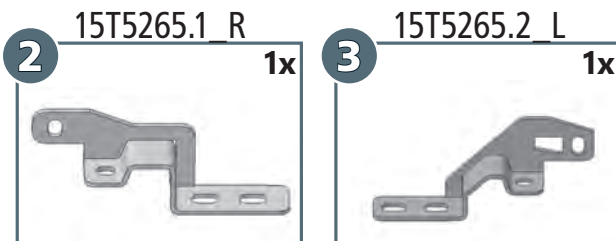

article no.:

15T4237S inox black
15T5237 steel black

Revision 4: 07.06.2022



ULLSTEIN
CONCEPTS
GMBH

page/Seite 2

Vorbereitung Elektrik

Elektro-kit

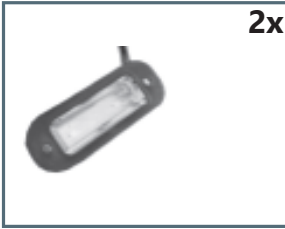

- 4 St. Quetschverbinder
- 2 St. Kabel 2 adrig 1,3m lang
- 4 St. Kabelschuhe männlich
- 4 St. Kabelbinder
- 4 St. Schrumpfschlauch

Step 1



Stoßfänger demontieren

Step 2

Stecker links unten abziehen



Step 3



Steckverbindungen in der Stoßstange zwischen Kennzeichenleuchte und Kabelbaum 2x lösen

Aus dem Steckergehäuse des Kabelbaums die Leitungen ausspinnen

Auf eine Seite der mitgelieferten Kabel die Kabelschuhe aufkröpfen.

Kabelschuhe und Kabelhülsen zusammenstecken und mit Schrumpfschlauch isolieren.

Step 4

Stoßfänger unten rechts und links wie dargestellt aus schneiden.

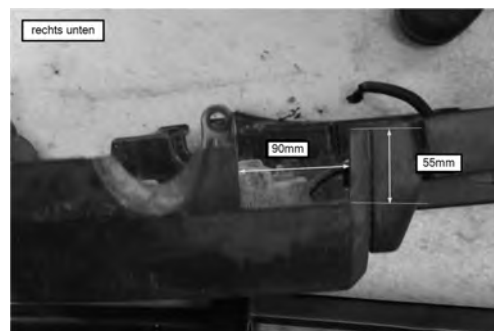
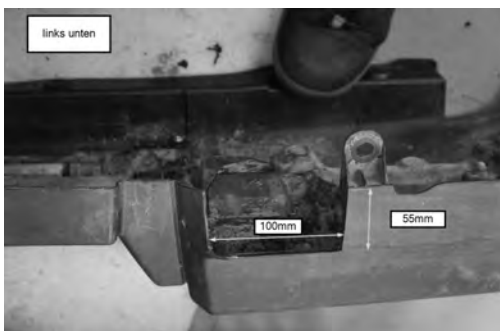

Step 4 Kabel mit Kabelbindern am Stoßfänger sichern

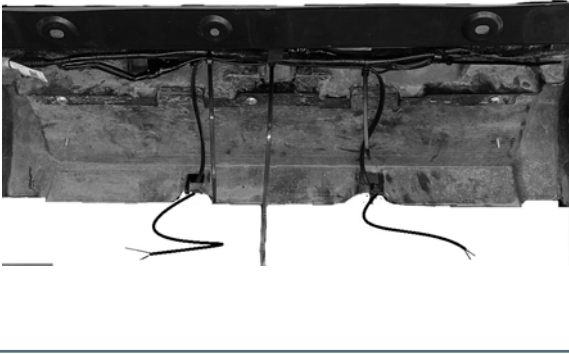

Step 5 Stoßfänger montieren



Step 6

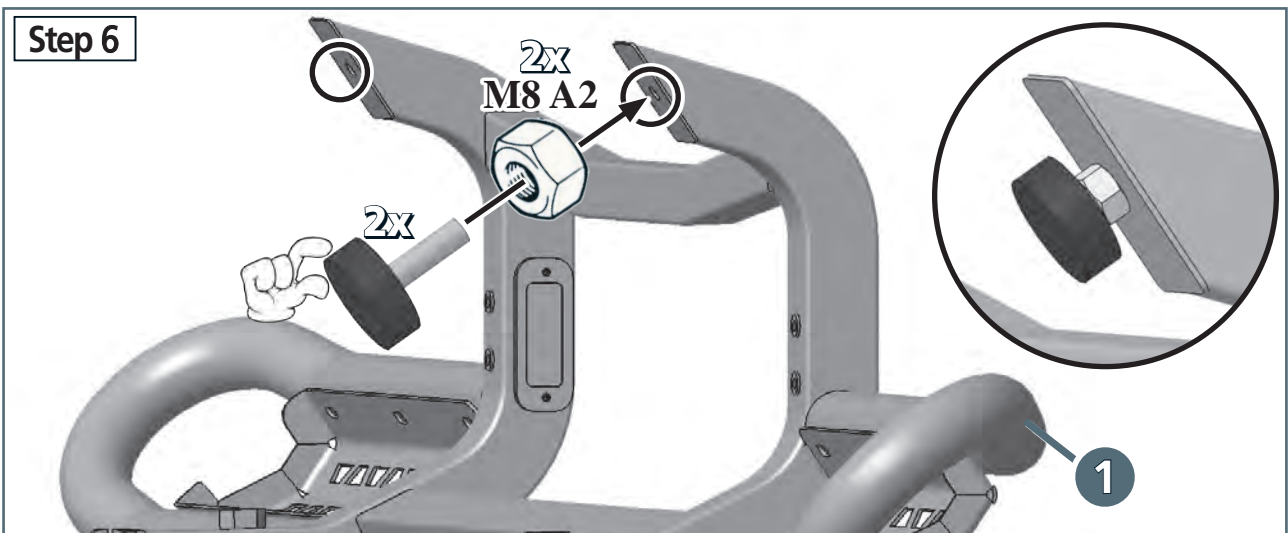

Step 7

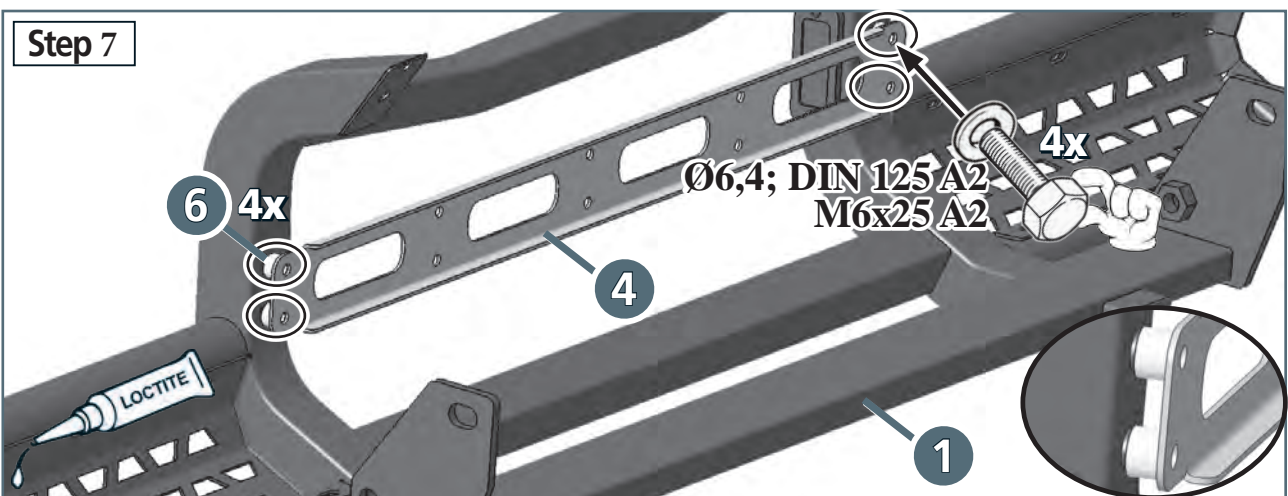

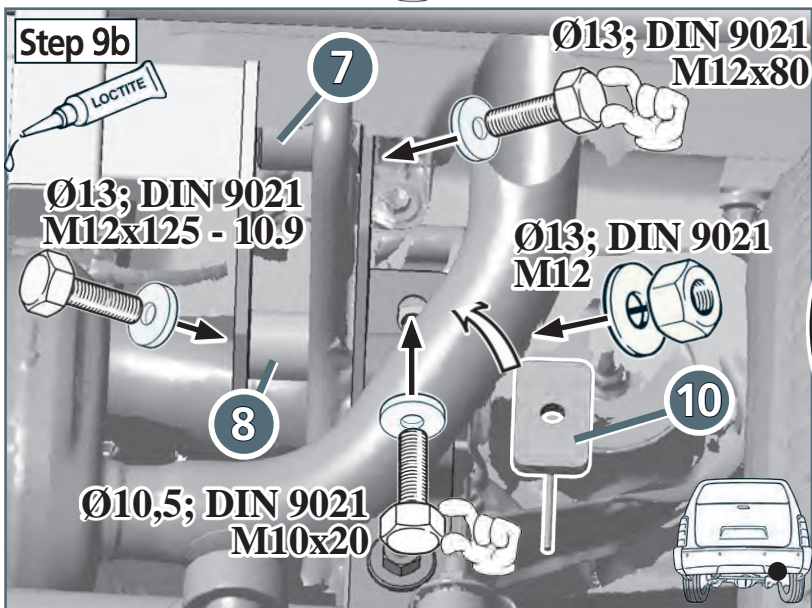
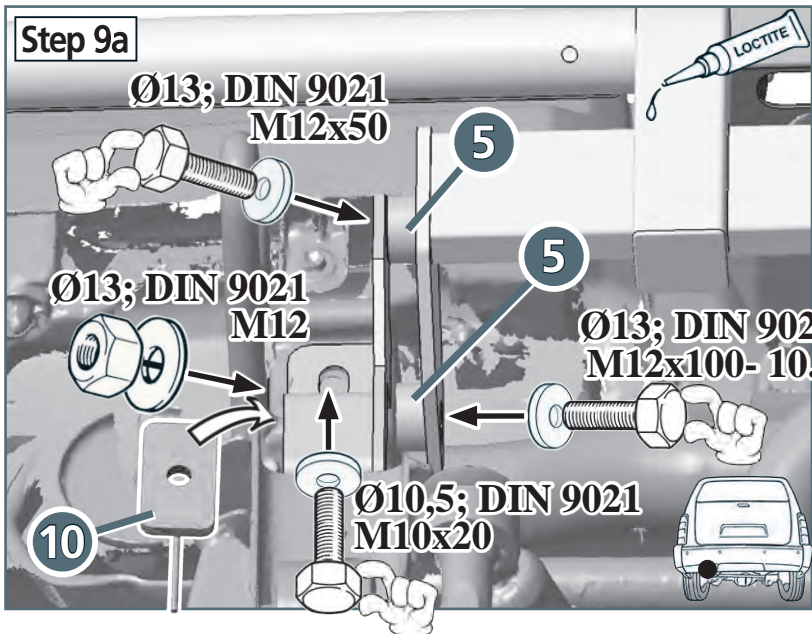
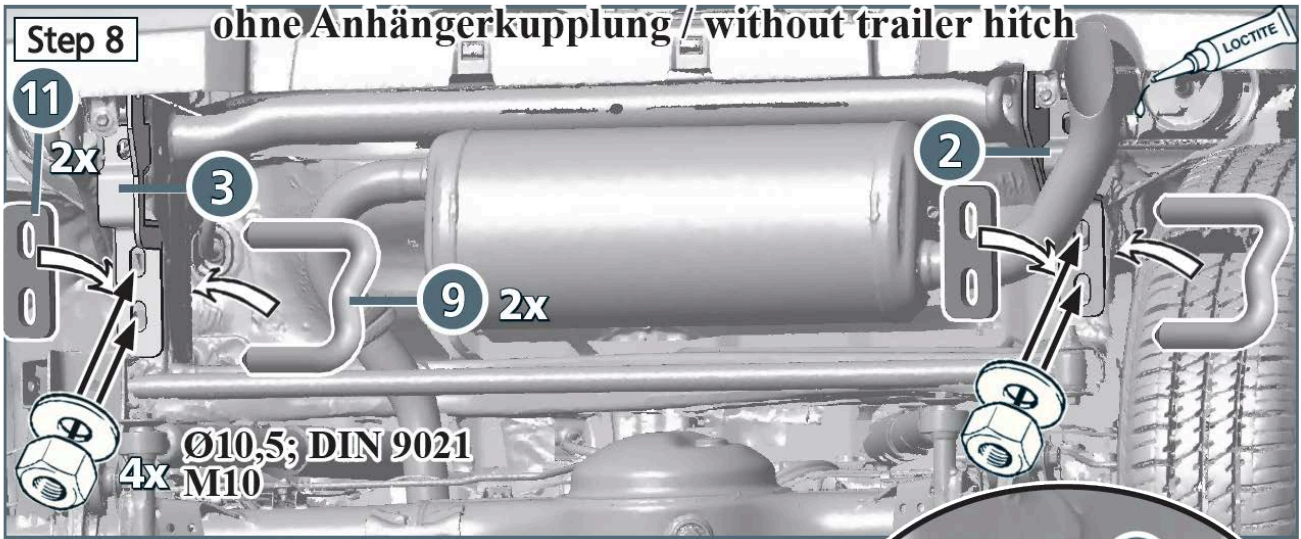

Seite 6 mit Step 10 fortfahren

Revision 4: 07.06.2022



ULLSTEIN
CONCEPTS
GMBH

page/Seite 5

Step 8

mit Anhängerkupplung / with trailer hitch

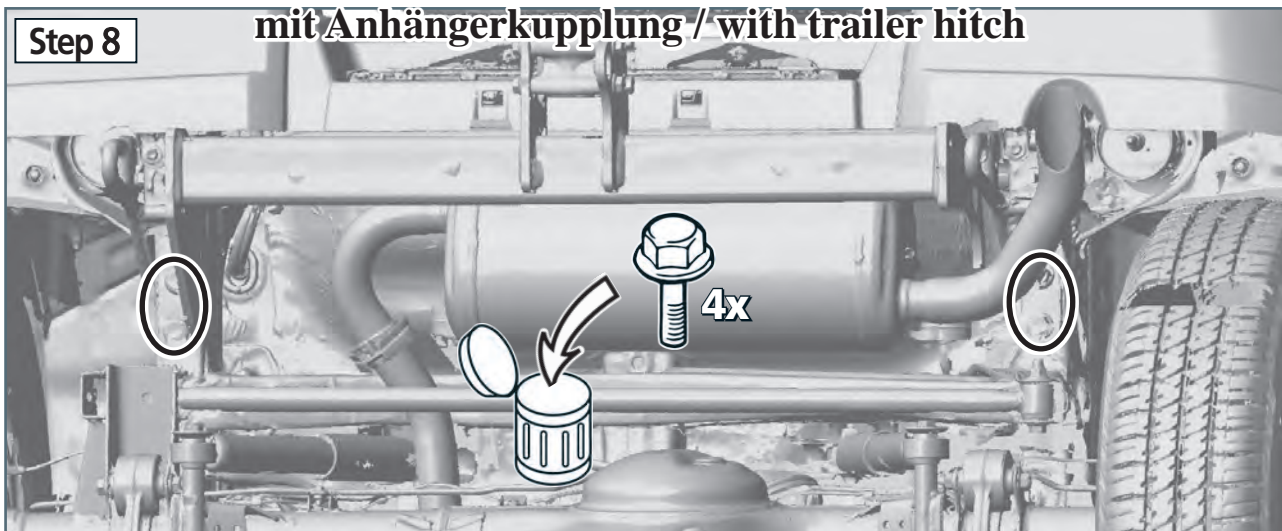

Step 9a

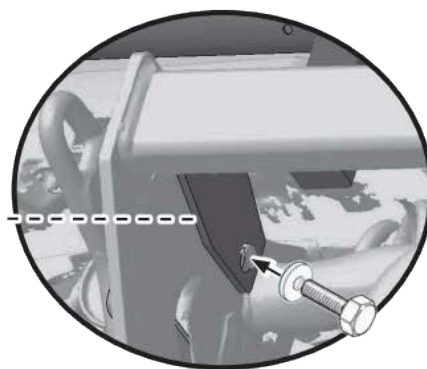
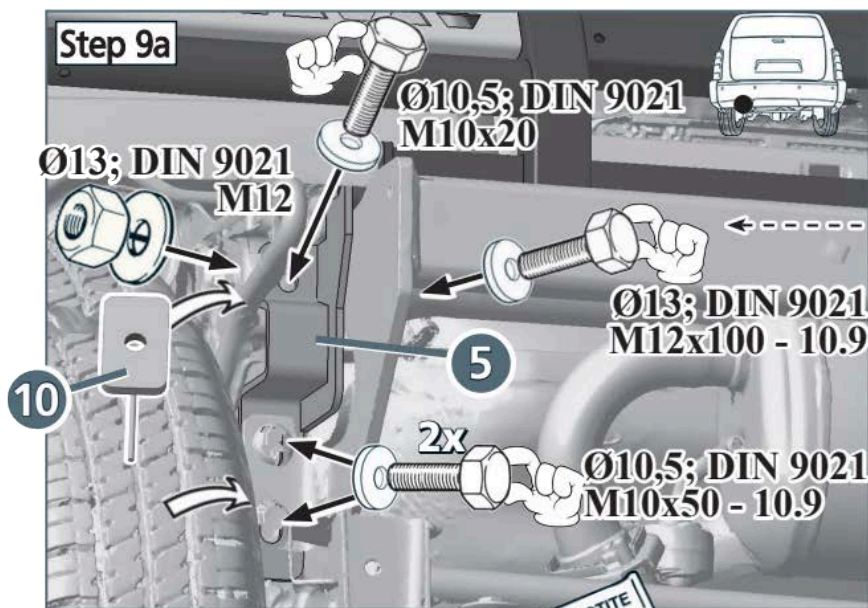

Step 9b

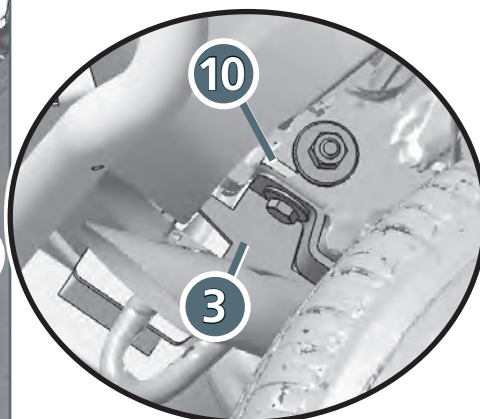
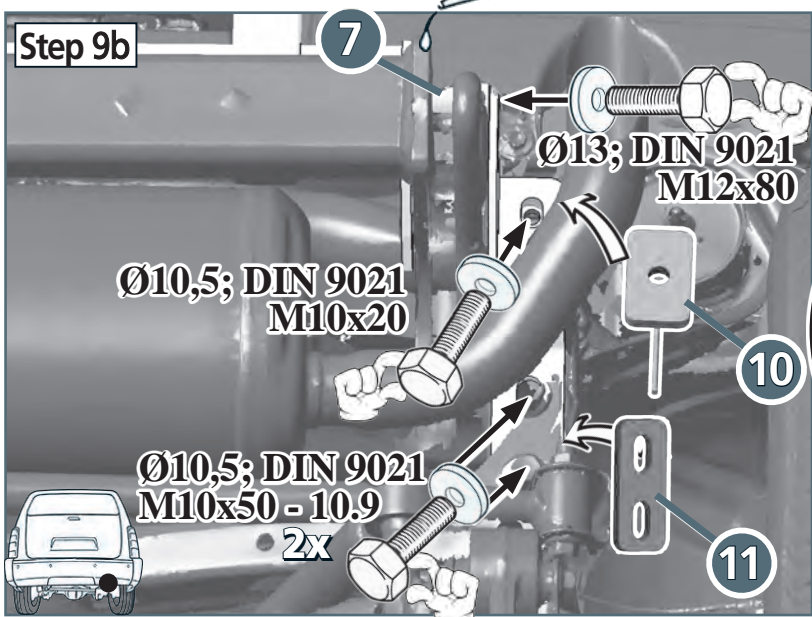

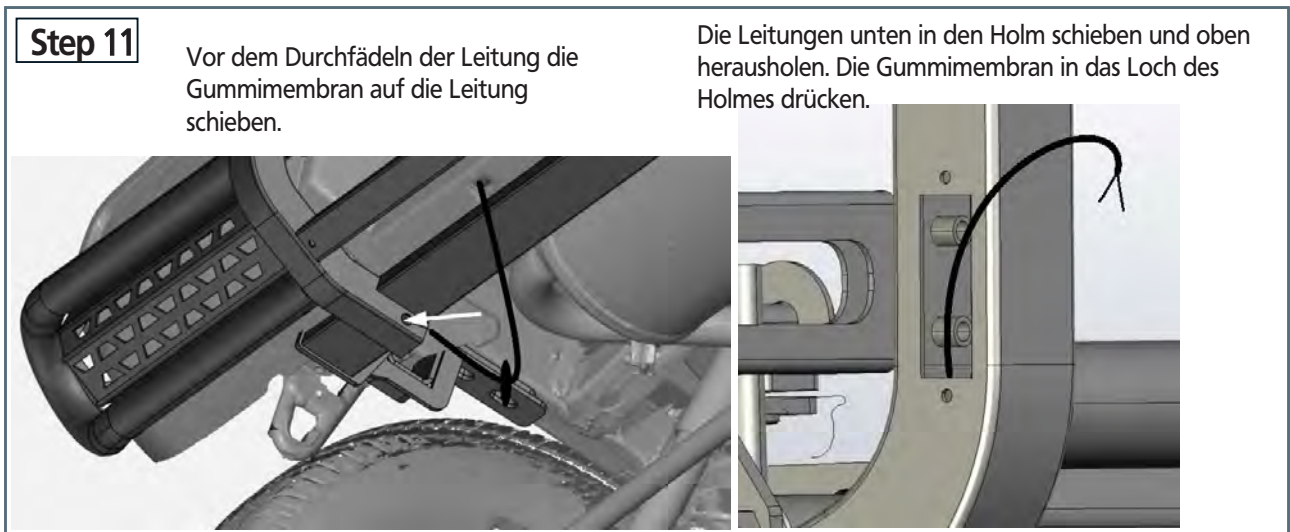
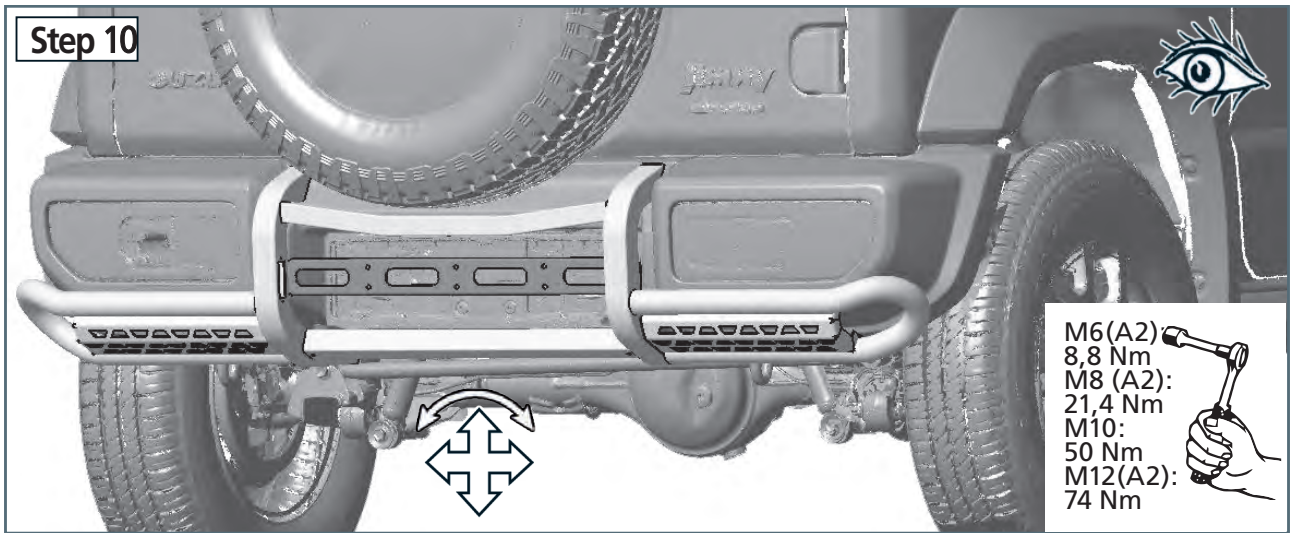

Elektrische Leitungen verbinden, Funktion überprüfen und Leuchte anschrauben

