

Schublade 1700 / Montagesatz mit 11E9290
Drawer 1700 / Assembly-kit with 11E9290
Tiroir 1700 / Assemble-kit avec 11E9290

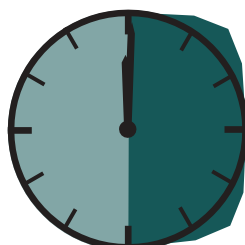

Assembly INSTRUCTION

Montageanleitung • Instructions de montage



90 Minuten

article-no:
006085 black Steel

Revision 5: 07.02.2019



ULLSTEIN
CONCEPTS
GMBH

Schublade 1700 / Montagesatz mit 11E9290

Drawer 1700 / Assembly-kit with 11E9290

Tiroir 1700 / Assemble-kit avec 11E9290



Required tools / Benötigte Werkzeuge / Outillage requis

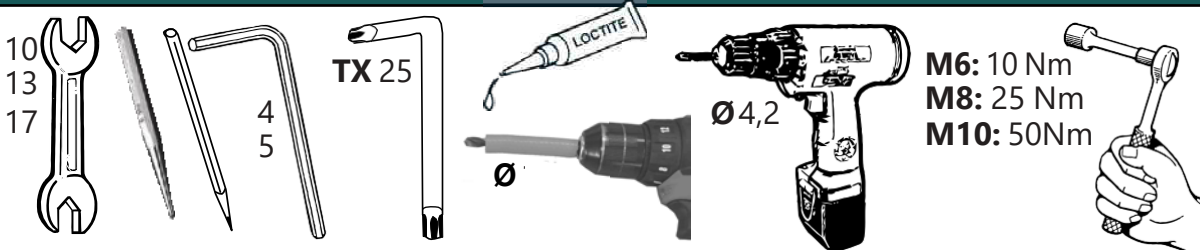

M6: 10 Nm
M8: 25 Nm
M10: 50Nm

Parts list/Teileliste/Lista de accesorios

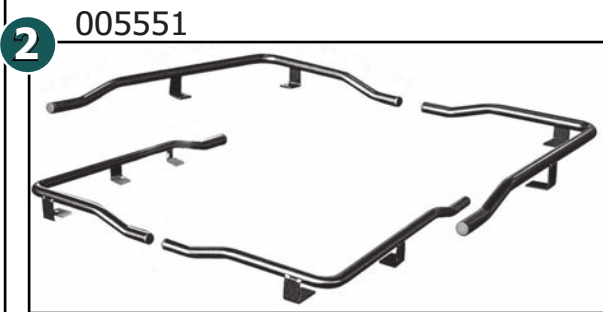

a		ø5,5x25; DIN 7976	2x
b		M6x30; DIN 7991	14x
c		M6x12; ~ISO7380	10x
d		M6x25; ~ISO7380	8x
e		M6x20; DIN 933	2x
f		M8x20; DIN 933	2x
g		M6 weld nut/Anschweißmutter/ soudure écrou	10x
l		ø6,4; DIN 9021	6x
m		M6; DIN 985 Zn	2x
n		M6; DIN 934 Zn	14x

8 ø9; 005497 **2x** **9** ø6,6; 005495 **14x**

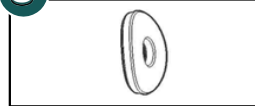

Assembly-kit / Montagesatz / Assemble-kit

11E9290

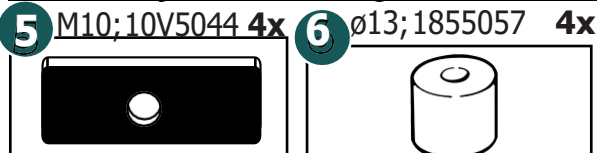

7 ø11; 005493 **8x**



o		M10x60; DIN 933	4x
p		M10; DIN 934	4x

article-no:
006085 black Steel

Revision 5: 07.02.2019



ULLSTEIN
CONCEPTS
GMBH

Schublade 1700 / Montagesatz mit 11E9290
Drawer 1700 / Assembly-kit with 11E9290
Tiroir 1700 / Assemble-kit avec 11E9290



4

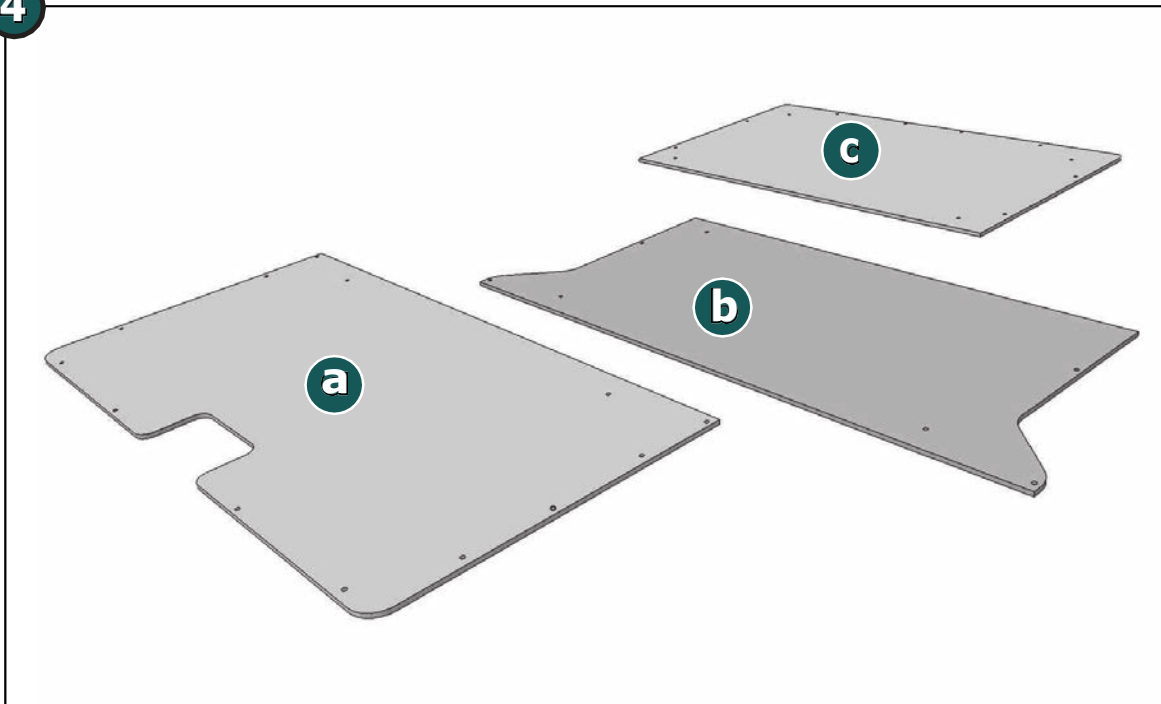

Artikel-Nr. Item-Nr. numéro d'article	KFZ Hersteller auto- motive manufacturer constructeur automobile	Bezeichnung designation désignation	Modell model modèle	Holzauflagen timber vehicle part exigences bois	A	B
11E5890N	Toyota	Hilux Extra Cab	11/2006 ->	005566N	85	217

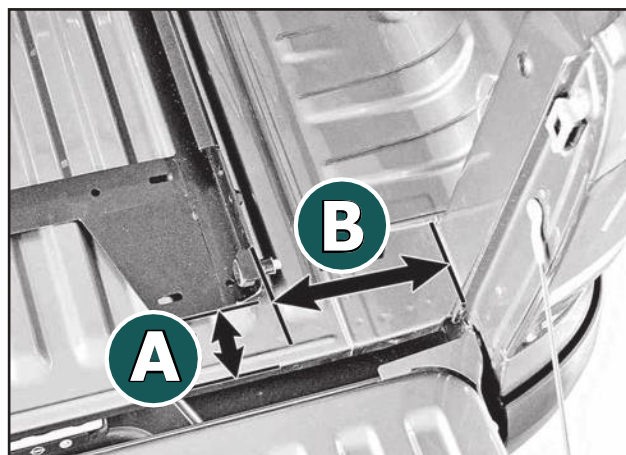

article-no:
006085 black Steel

Revision 5: 07.02.2019



ULLSTEIN
CONCEPTS
GMBH

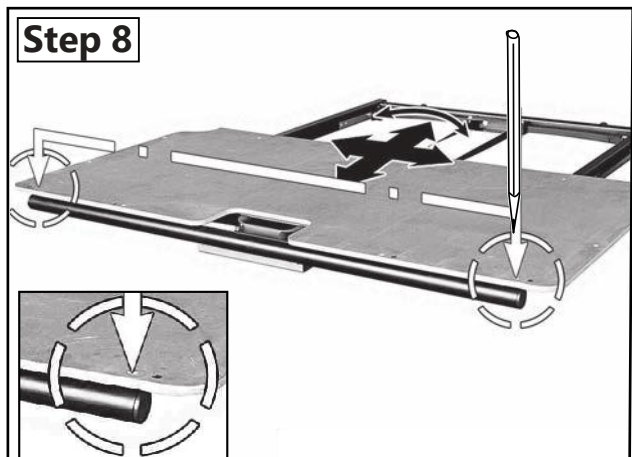
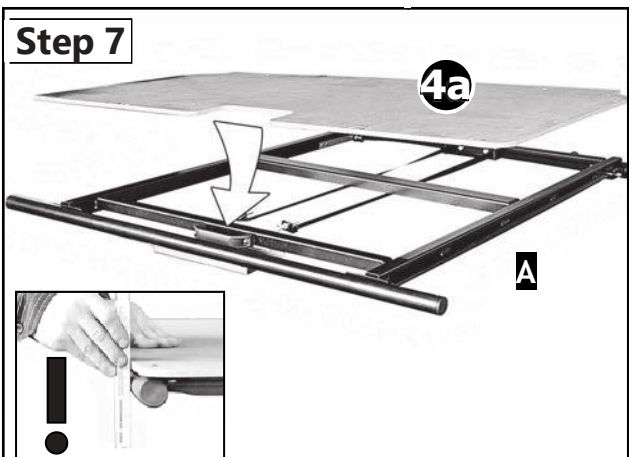
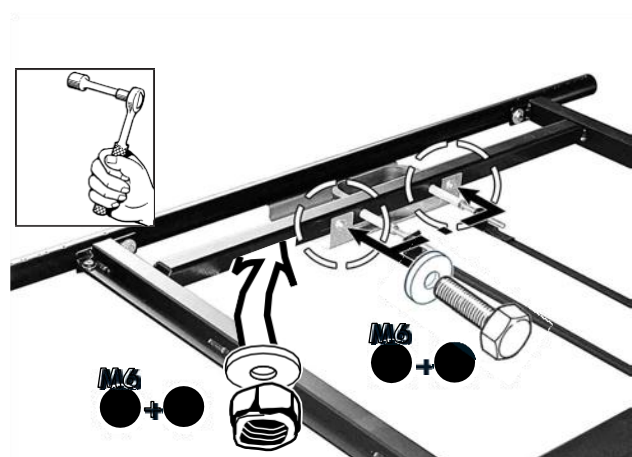
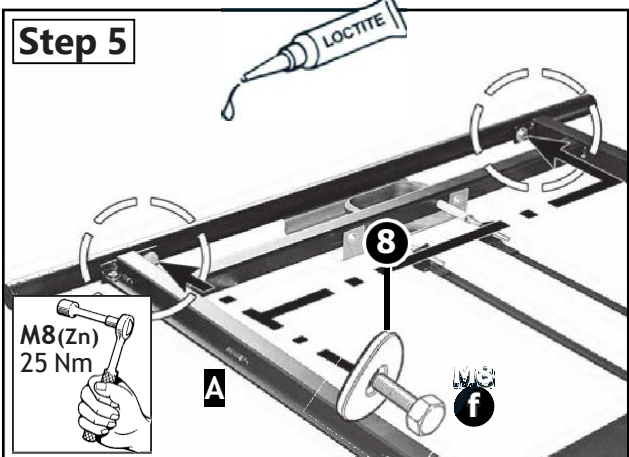
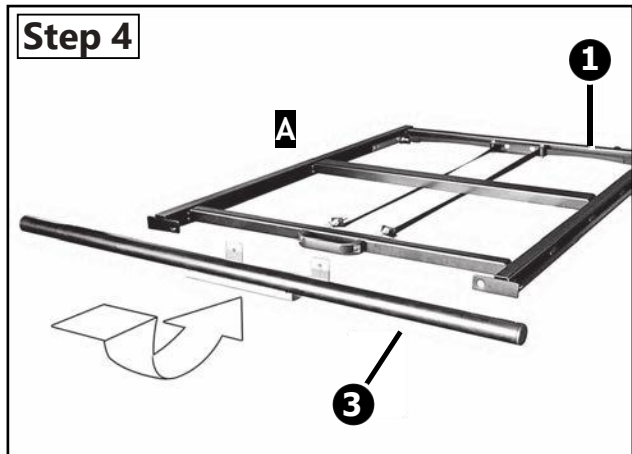
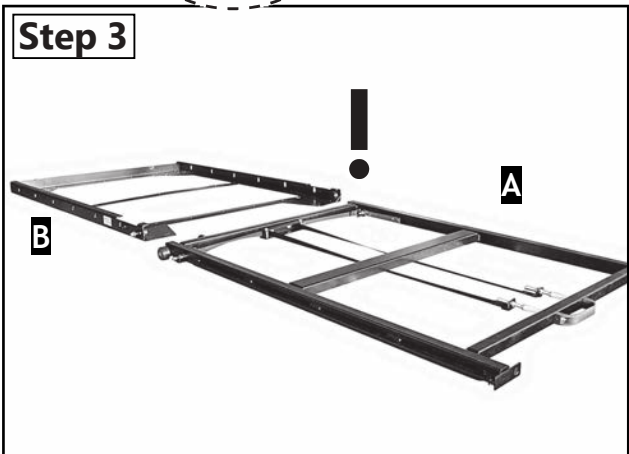
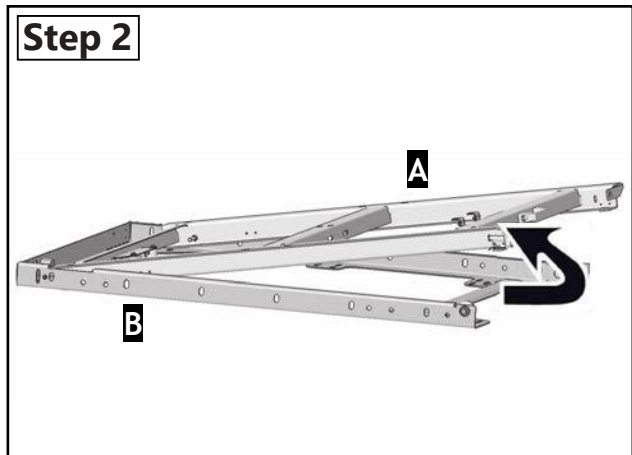
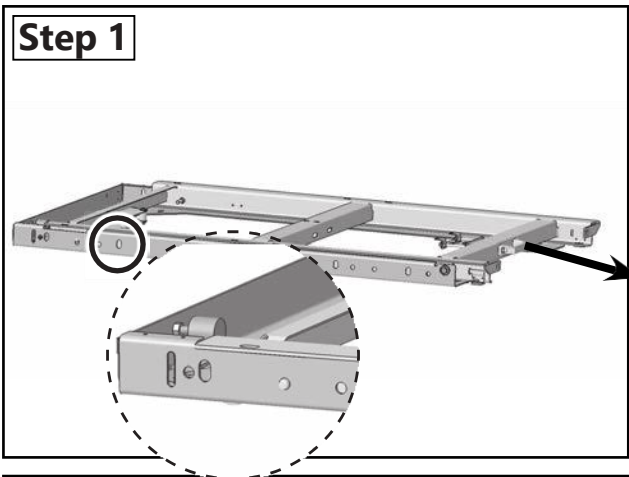

article-no:
006085 black Steel

Revision 5: 07.02.2019



ULLSTEIN
CONCEPTS
GMBH

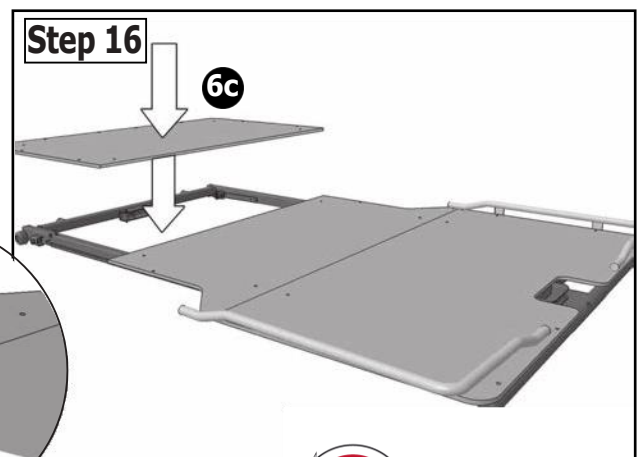
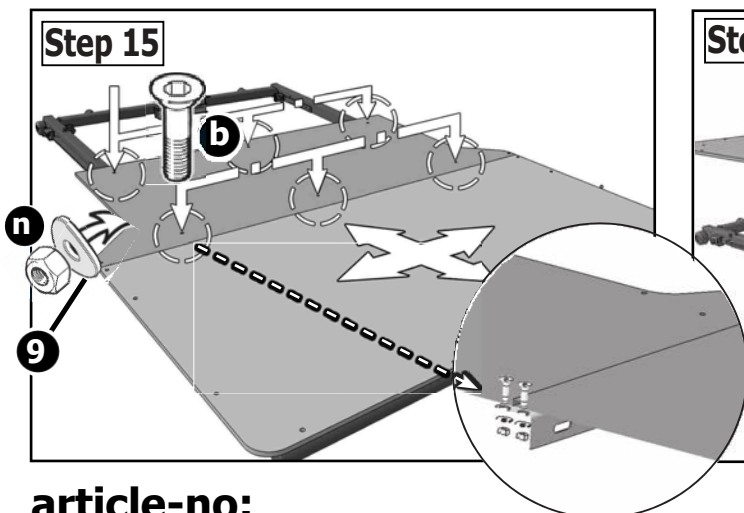
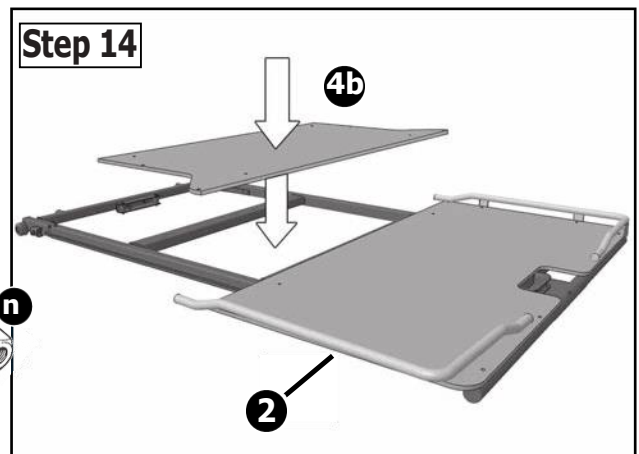
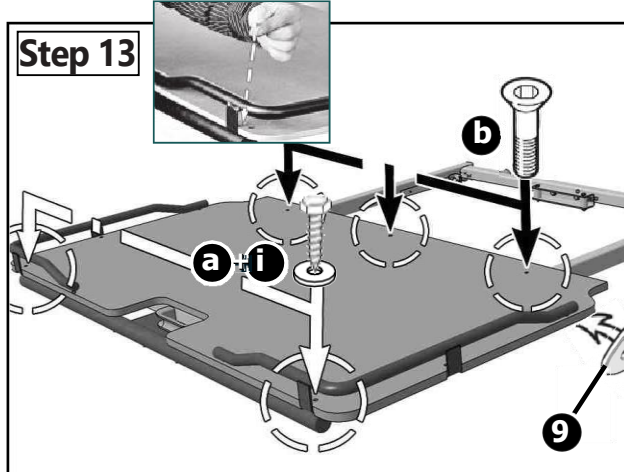
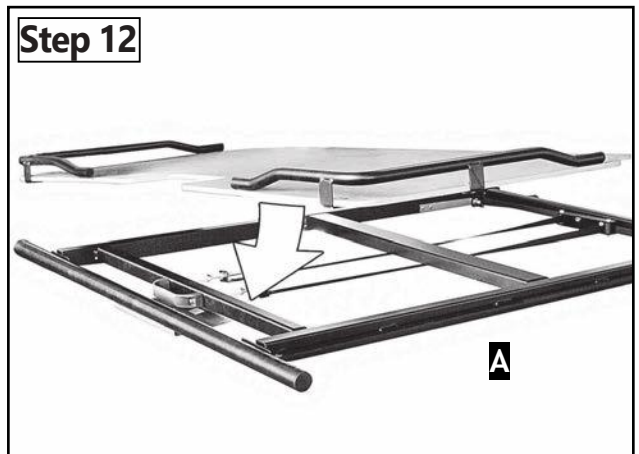
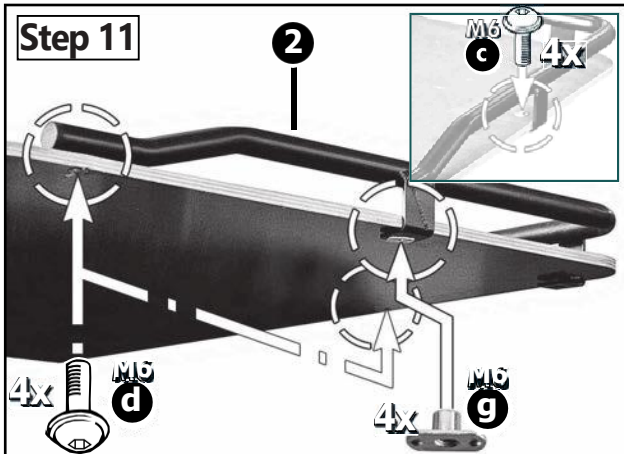
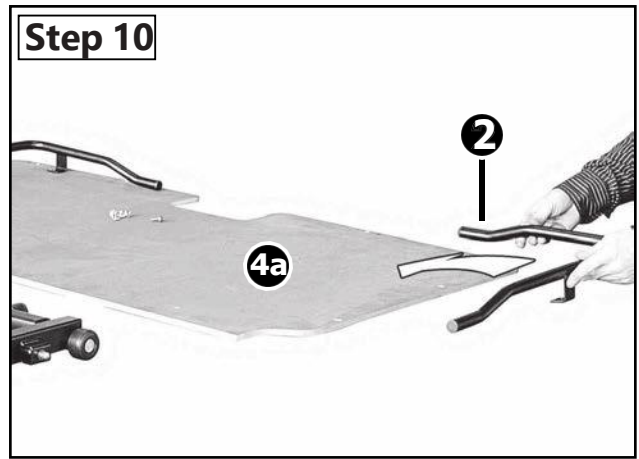
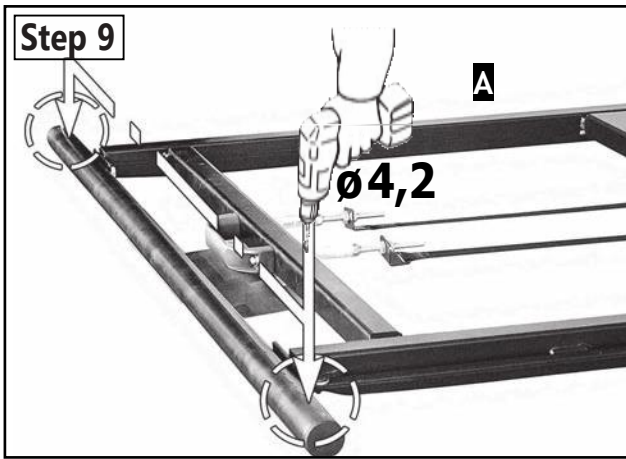

article-no:
006085 black Steel

Revision 5: 07.02.2019



ULLSTEIN
CONCEPTS
GMBH

Step 17

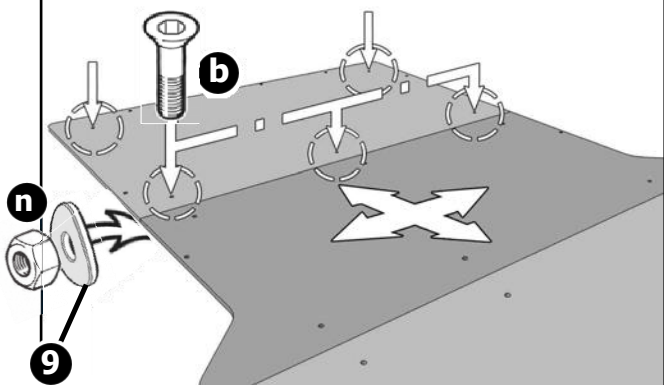

Step 18

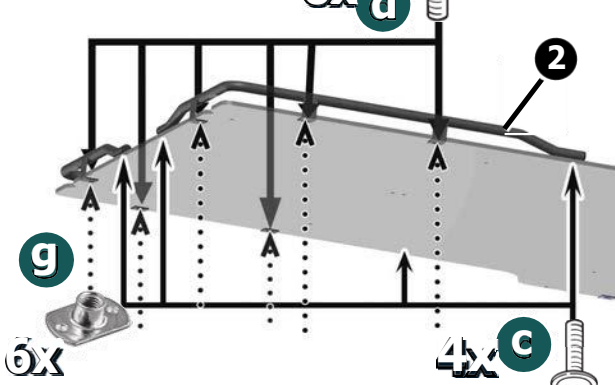

Step 19



Step 20

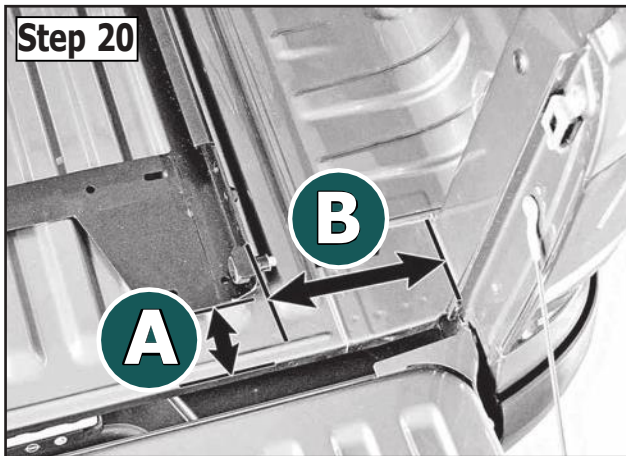

Step 21

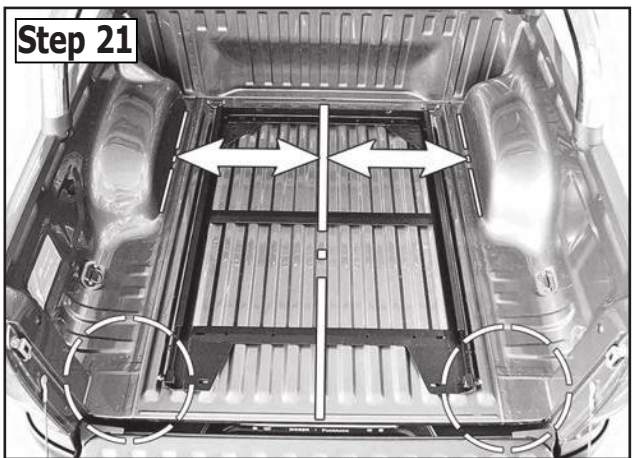

Step 22



Step 23



Step 24



article-no:
006085 black Steel

Revision 5: 07.02.2019



ULLSTEIN
CONCEPTS
GMBH

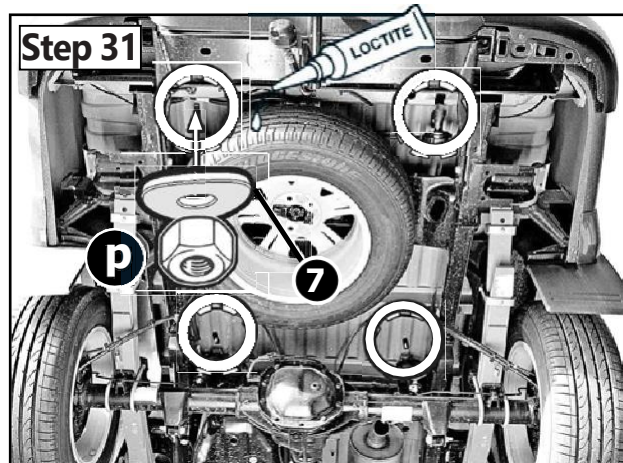
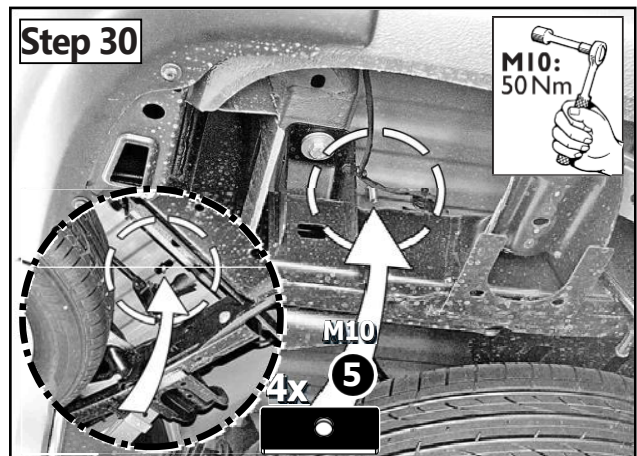
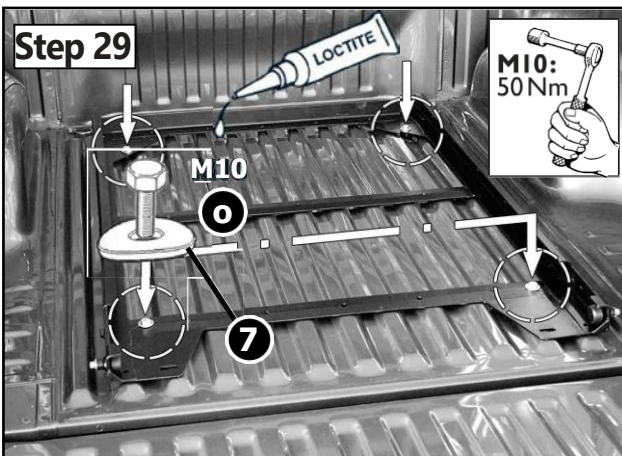
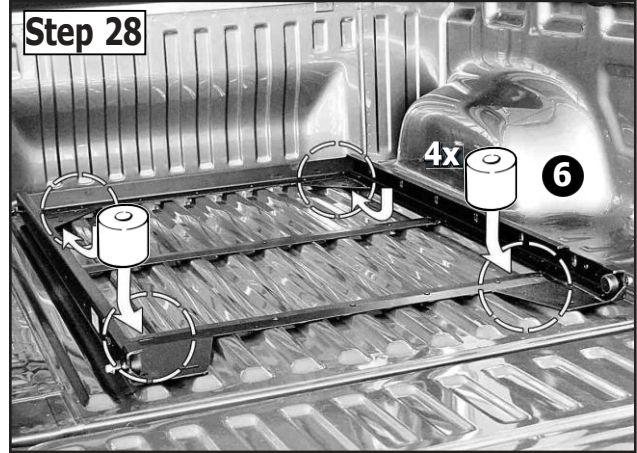
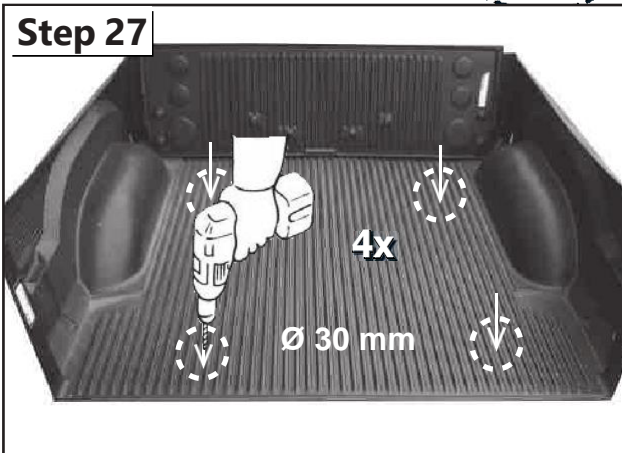
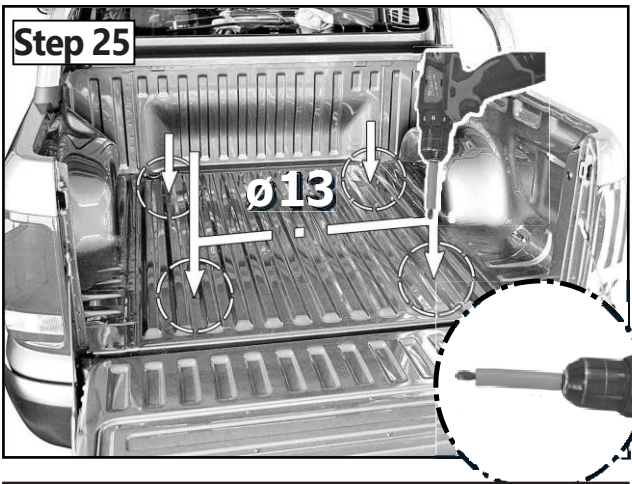

article-no:
006085 black Steel

Revision 5: 07.02.2019



ULLSTEIN
CONCEPTS
GMBH

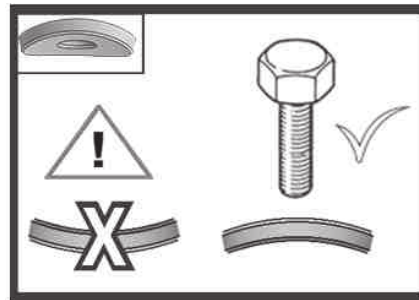
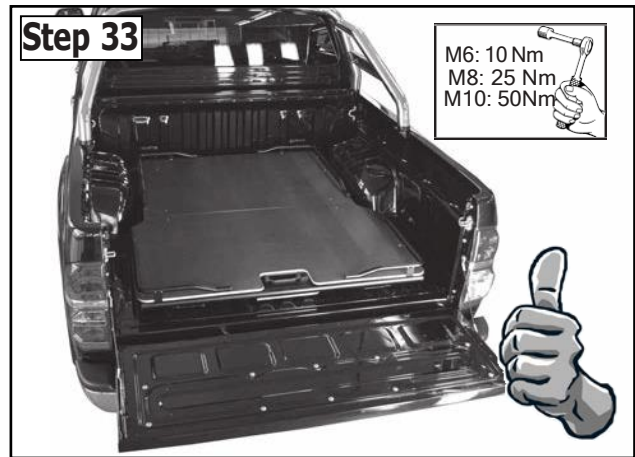
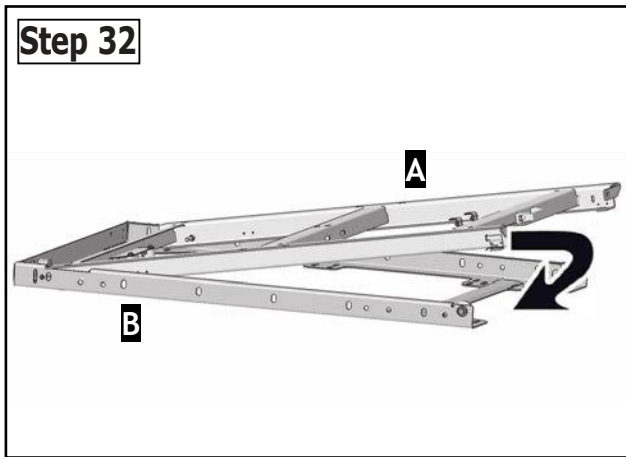

**350 kg
max**



article-no:
006085 black Steel

Revision 5: 07.02.2019



**ULLSTEIN
CONCEPTS
GMBH**