





MOUNTAIN TOP[®] EVOe

Installation manual

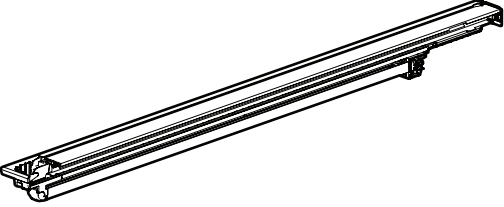
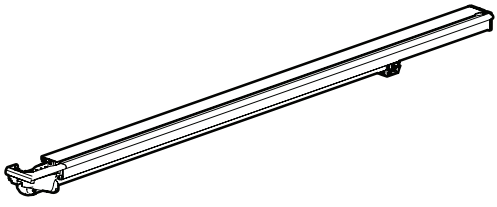
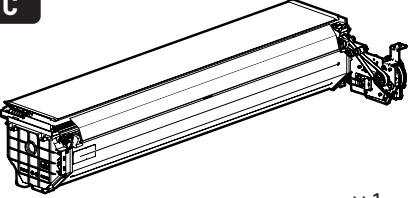

DOWNLOAD PDF

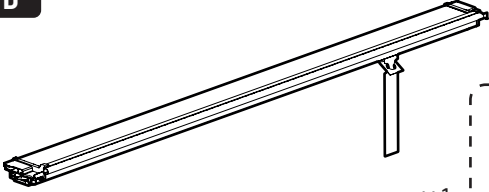

Parts

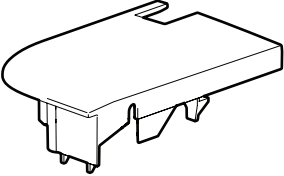
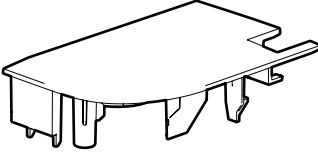

| | |
|--|---|
| <p>A</p>  <p>x1</p> | <p>B</p>  <p>x1</p> |
| <p>C</p>  <p>x1</p> <div style="border: 1px dashed black; padding: 2px; display: inline-block;"> <p>X2</p>  <p>x2</p> </div> | <p>D</p>  <p>x1</p> <div style="border: 1px dashed black; padding: 2px; display: inline-block;"> <p>Y2</p>  <p>x1</p> </div> |

Kit

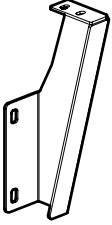
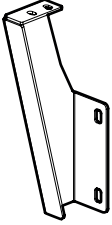
| | |
|--|--|
| <p>E</p>  <p>LEFT x1</p> | <p>F</p>  <p>RIGHT x1</p> |
|--|--|

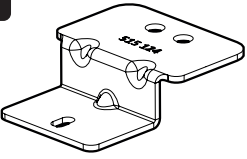
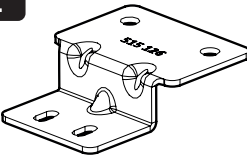
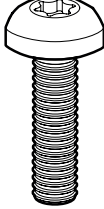
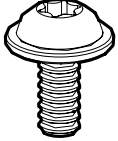
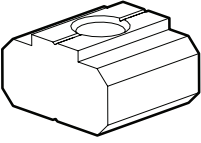
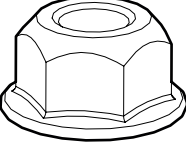
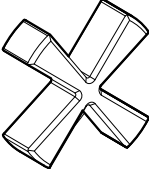
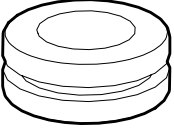
Kit

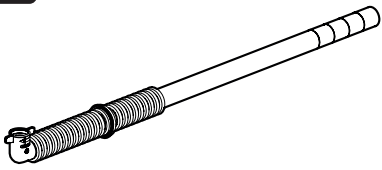
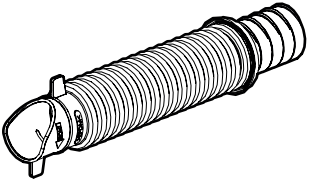
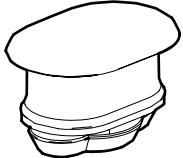
| | | | |
|---|---|--|---|
| <p>G</p>  <p>x1</p> | <p>H</p>  <p>x1</p> | <p>I</p>  <p>x1</p> | <p>J</p>  <p>x1</p> |
| <p>K</p>  <p>Rap Cab: x 0 Double Cab: x 2</p> | <p>L</p>  <p>Rap Cab: x 4 Double Cab: x 2</p> | <p>M</p>  <p>M8x30 x 18</p> | <p>N</p>  <p>Rap Cab: x 16 Double Cab: x 14</p> |
| <p>O</p>  <p>x6</p> | <p>P</p>  <p>x6</p> | <p>Q</p>  <p>x2</p> | <p>R</p>  <p>x1</p> |

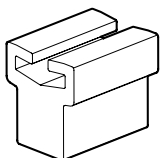
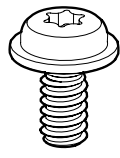
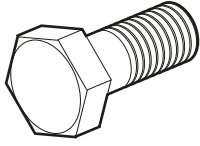
| Kit | | | |
|--|--|--|--|
| S  x2 | T  x2 | U  x2 | |
| V  M6x30 x2 | W  Rap Cab: x 7 Double Cab: x 5 | X  M6x16 Rap Cab: x 6 Double Cab: x 4 | Y  M6x14 x1 |

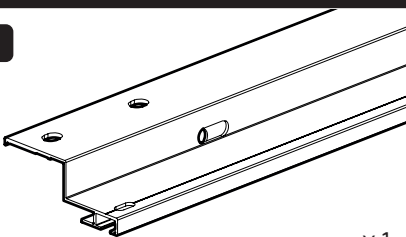
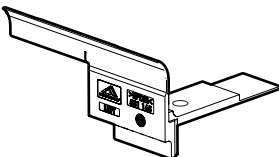
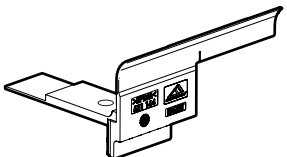
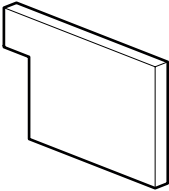
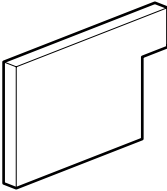
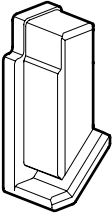
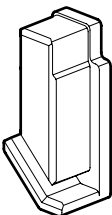
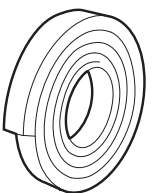
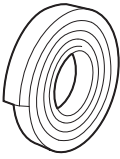
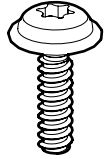
| Kit | | | |
|--|--|---|---|
| A2  x1 | B2  x1 | C2  x1 | |
| D2  x1 | E2  x1 | F2  x1 | |
| G2  x1 | H2  6x25mm x2 | I2  6x10mm x1 | J2  M5x14 x2 |

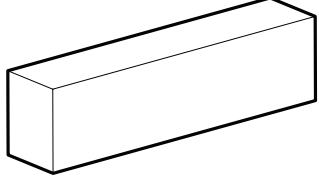
| Kit |
|---|
| K2  20x25x100mm x2 |

LED Kit

M2

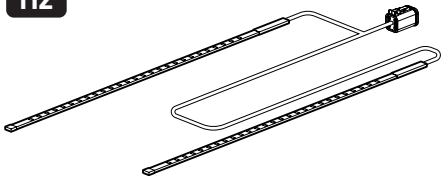

x1

N2

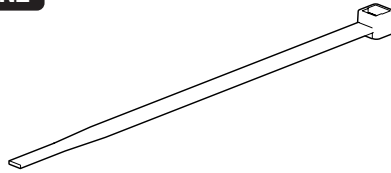

x6

O2

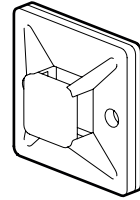

x6

Power supply kit

P2

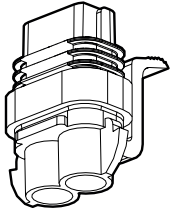

x1

Q2



x1

R2

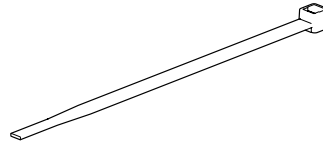

x16

S2

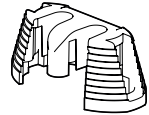

x1

Kit

T2

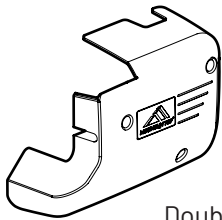

Double Cab: x1

U2

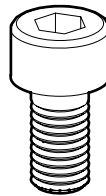

M5x10

Double Cab: x3

V2

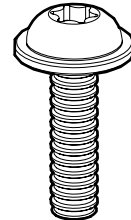

M6x20

x2

Kit

W2

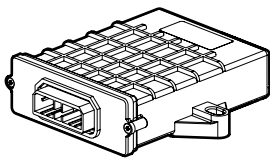

x1

Kit

Z2

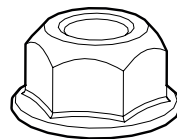

M6

x2

Z3

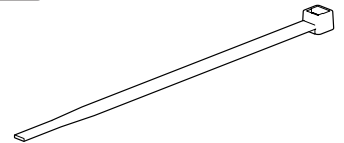

x10

Kit for Rap Cap

A3

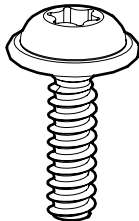

x2

B3

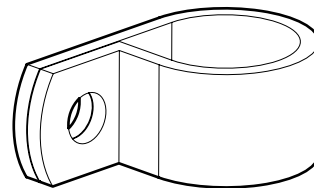

x2

Kit

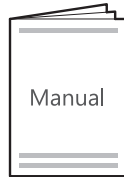

Manual

x1

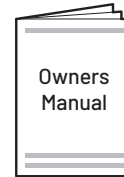

Owners
Manual

x1

Tools needed

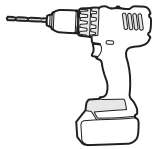

Ø3.5 + Ø10 MM

1 - 25 Nm

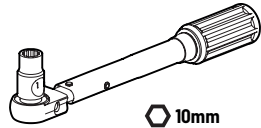

10mm
T20, T30, T40



Rust protection
Rostschutzmittel
Anti-rouille
Anti roest

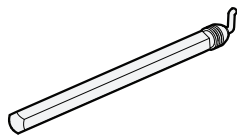
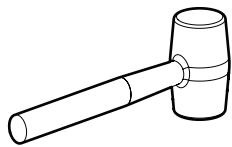

Silicone (RTV)

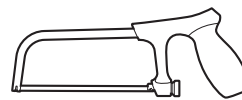
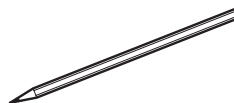
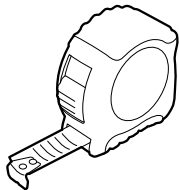
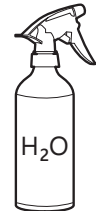
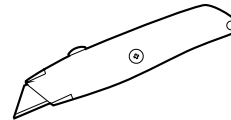

Applying rust protection

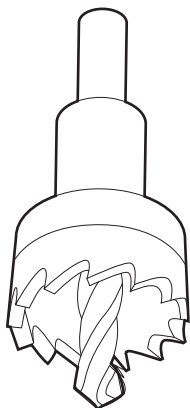

Ø18 / Ø30 / Ø40 mm

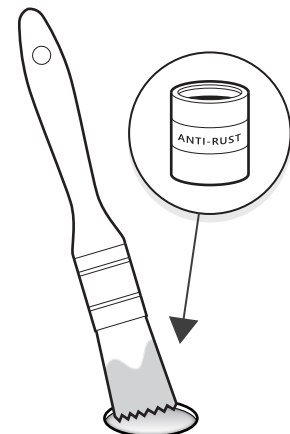
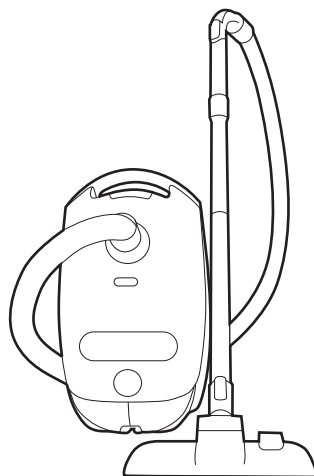



**If sheet metal is scratched during installation,
apply rust protection to damaged areas**



**Tie must not be attached to AC lines
(AC lines are the metal pipes in the engine bay)**



**Remove mass damper on tub
headboard prior to installing
Rollershutter (only applicable to
RAP CAB Variants)**

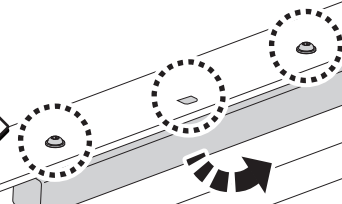

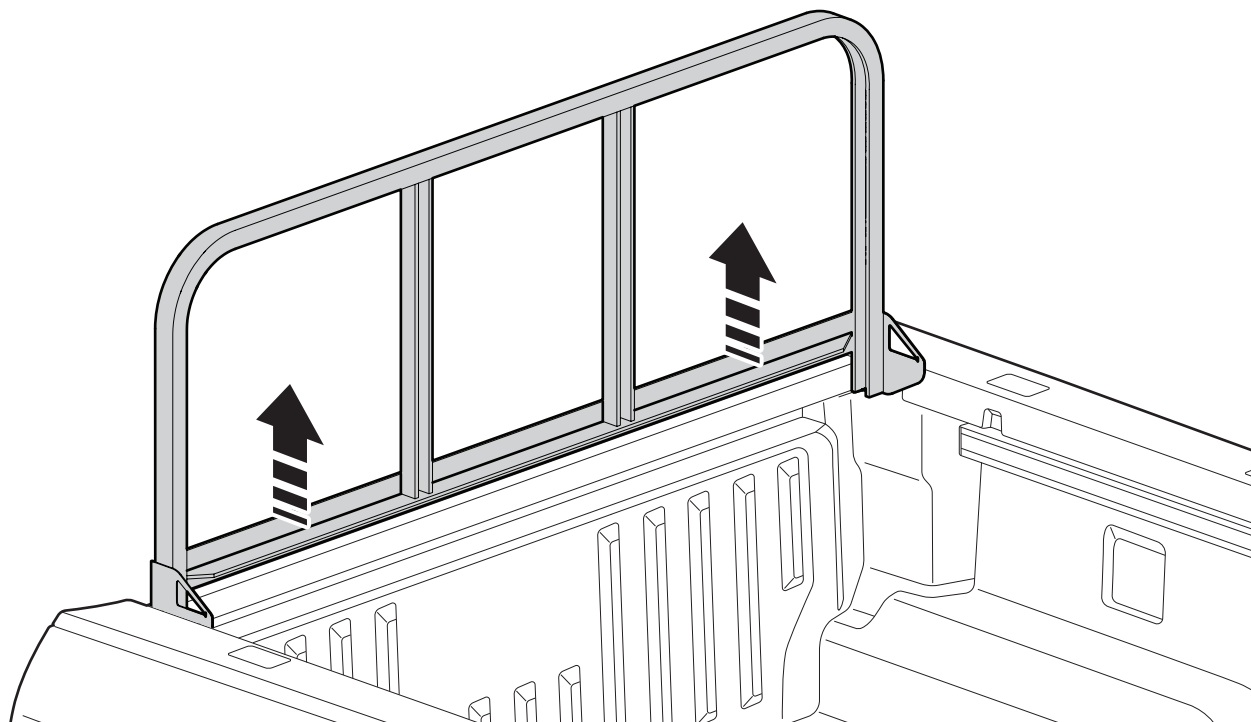

Rollershutter not compatible with load rest bar - part cannot be re-installed once Rollershutter have been installed (store parts)

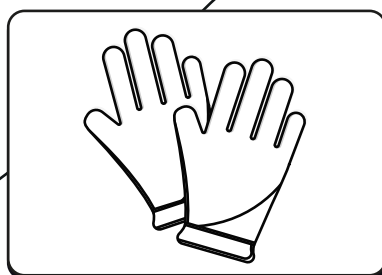

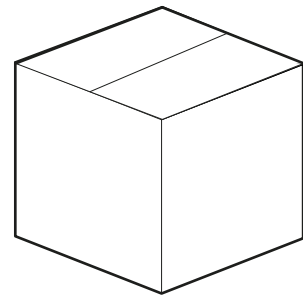
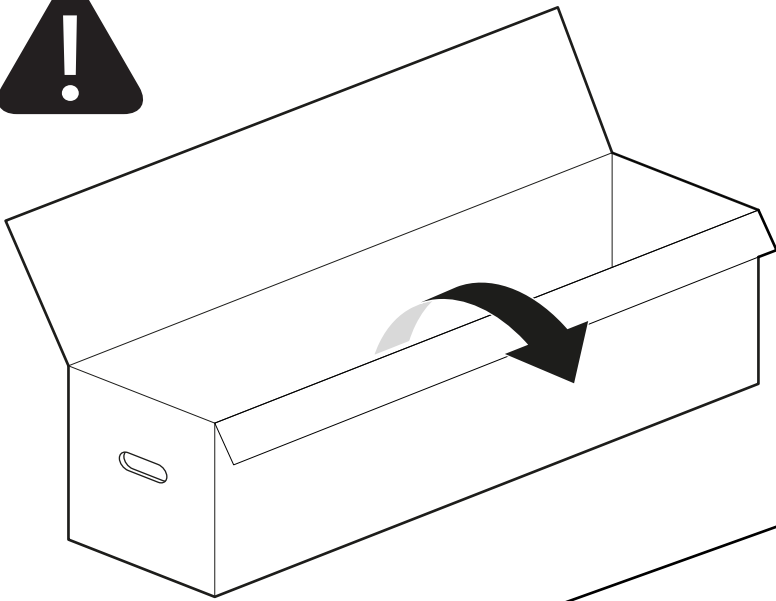

C

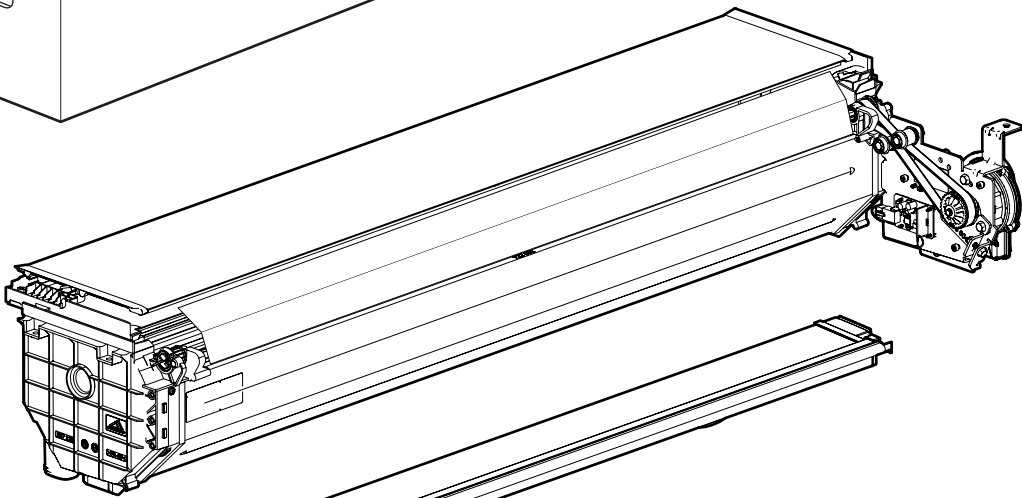

D

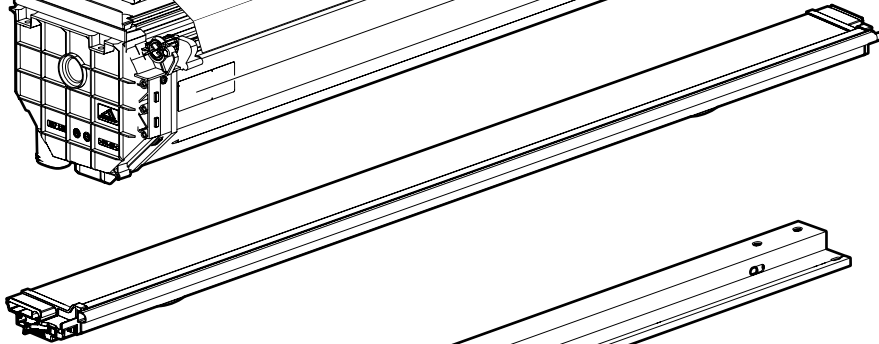

A2

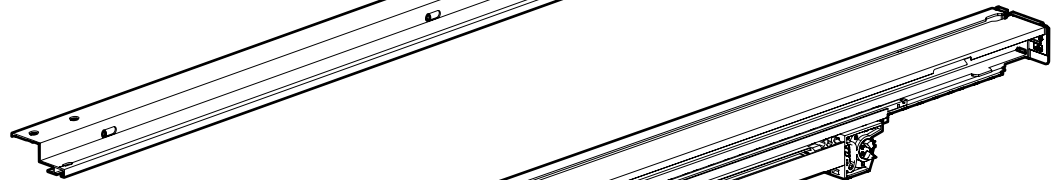

A

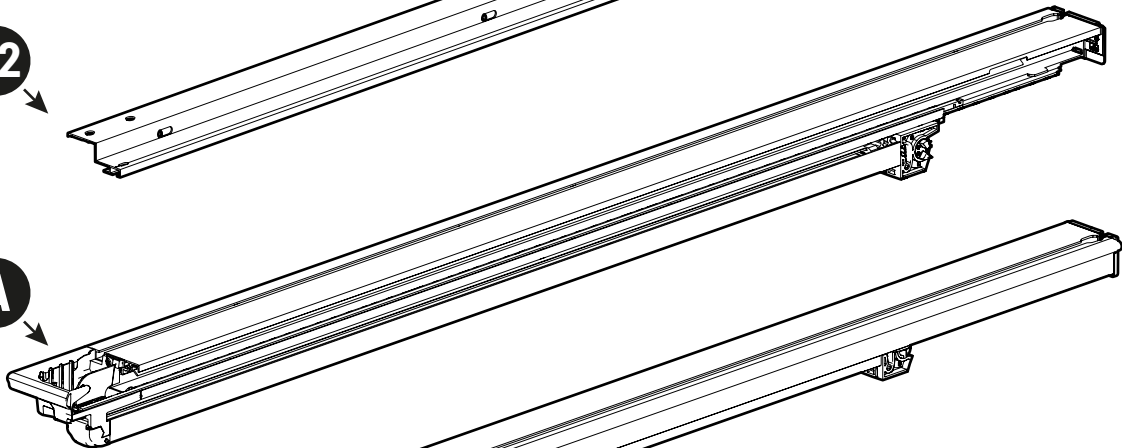

B

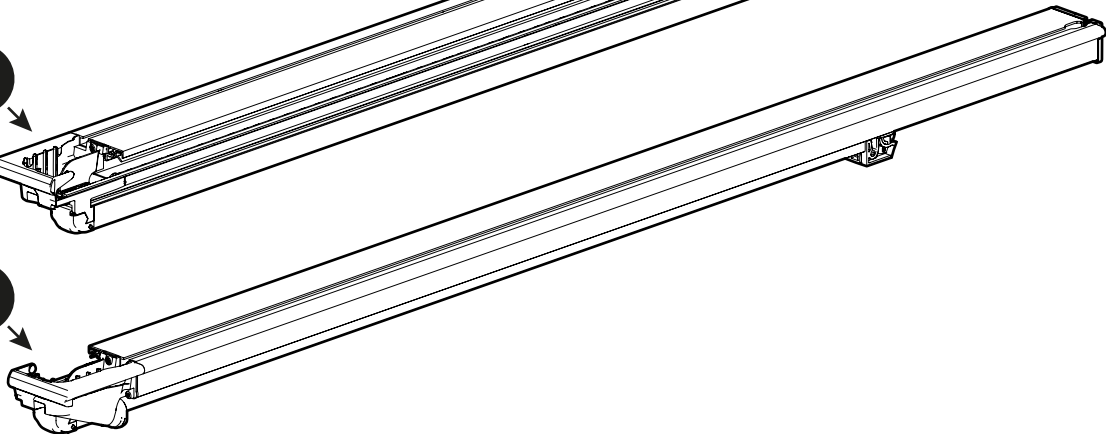

 Water & sponge



2

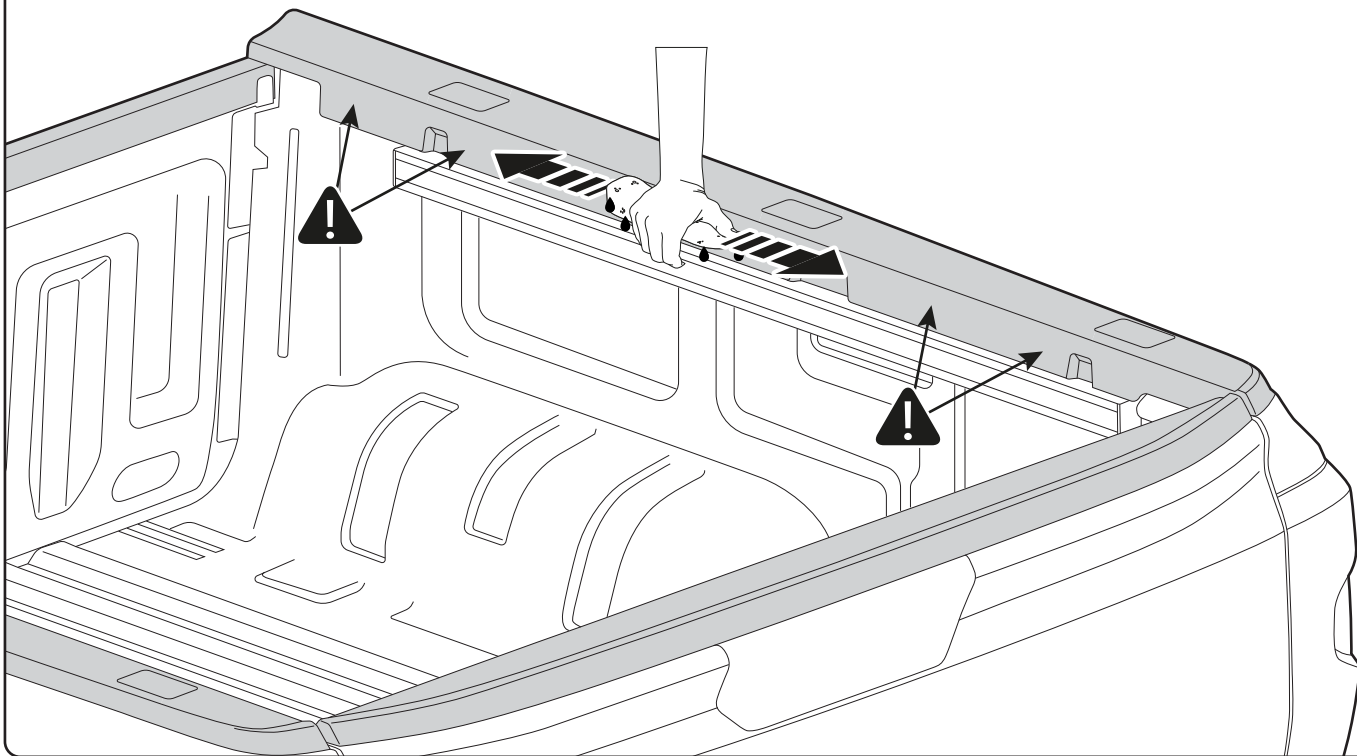

3

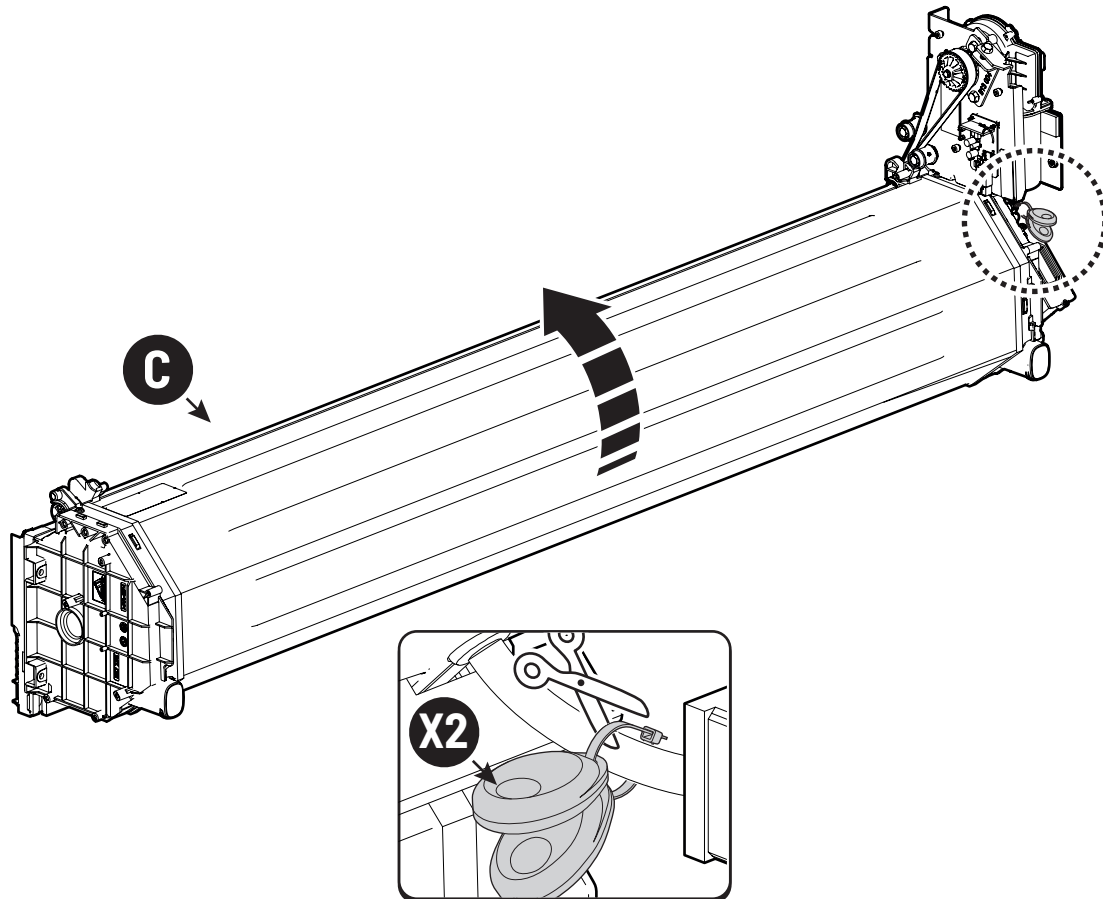

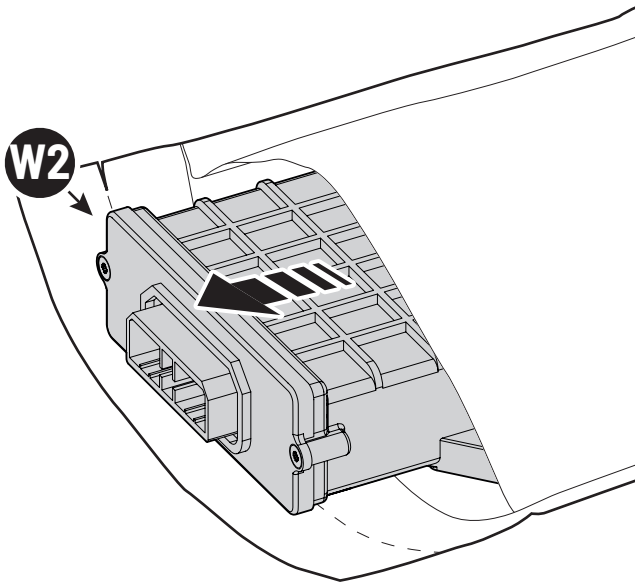

1

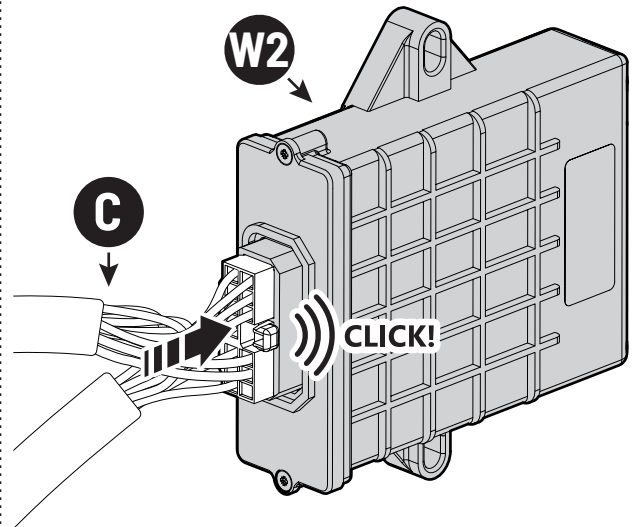

2

! ONLY FOR DOUBLE CAP

4mm **2,4Nm**

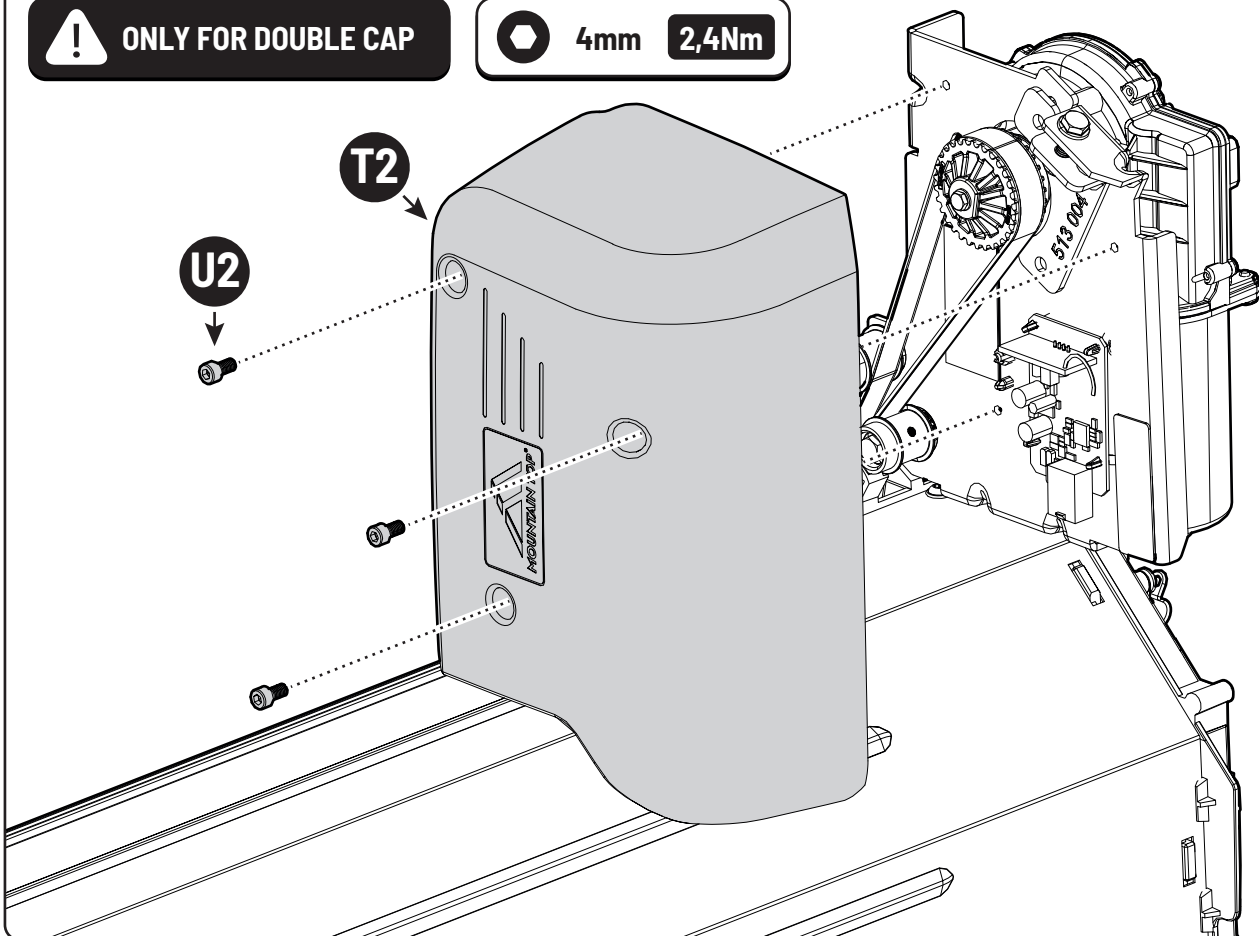

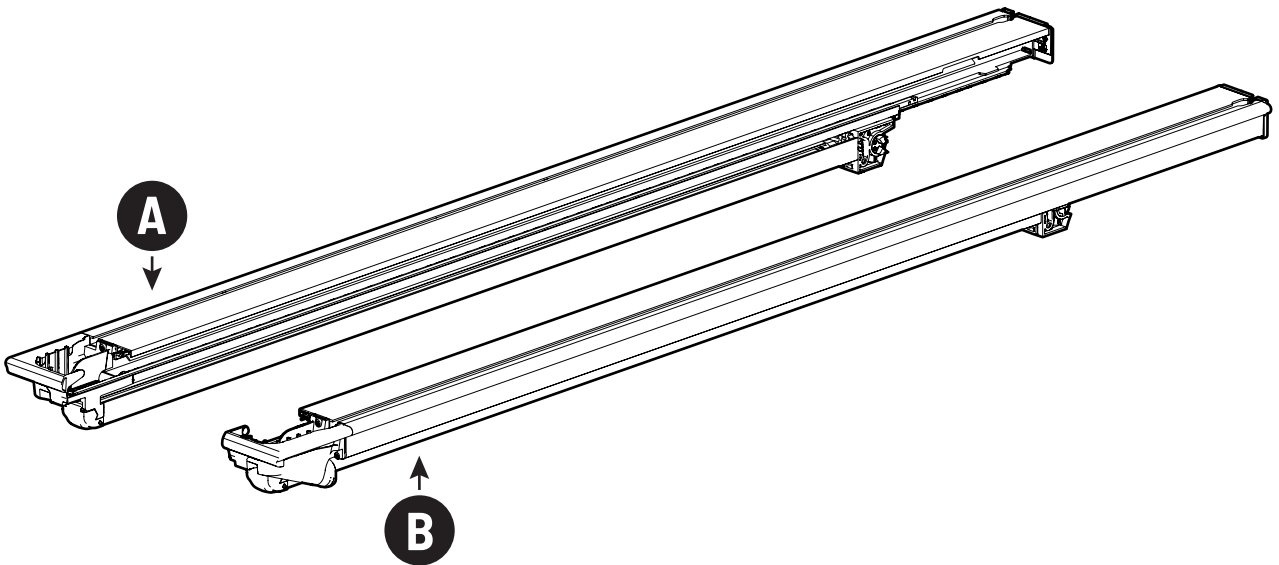
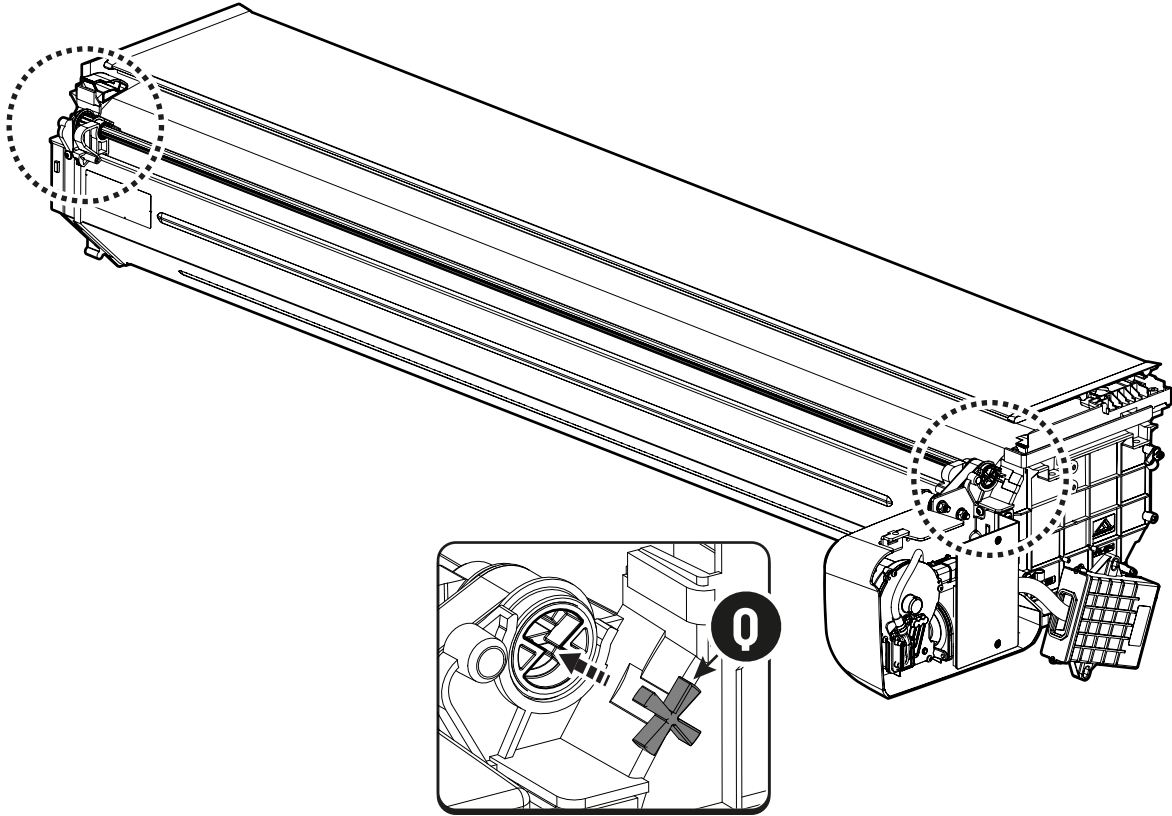
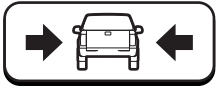

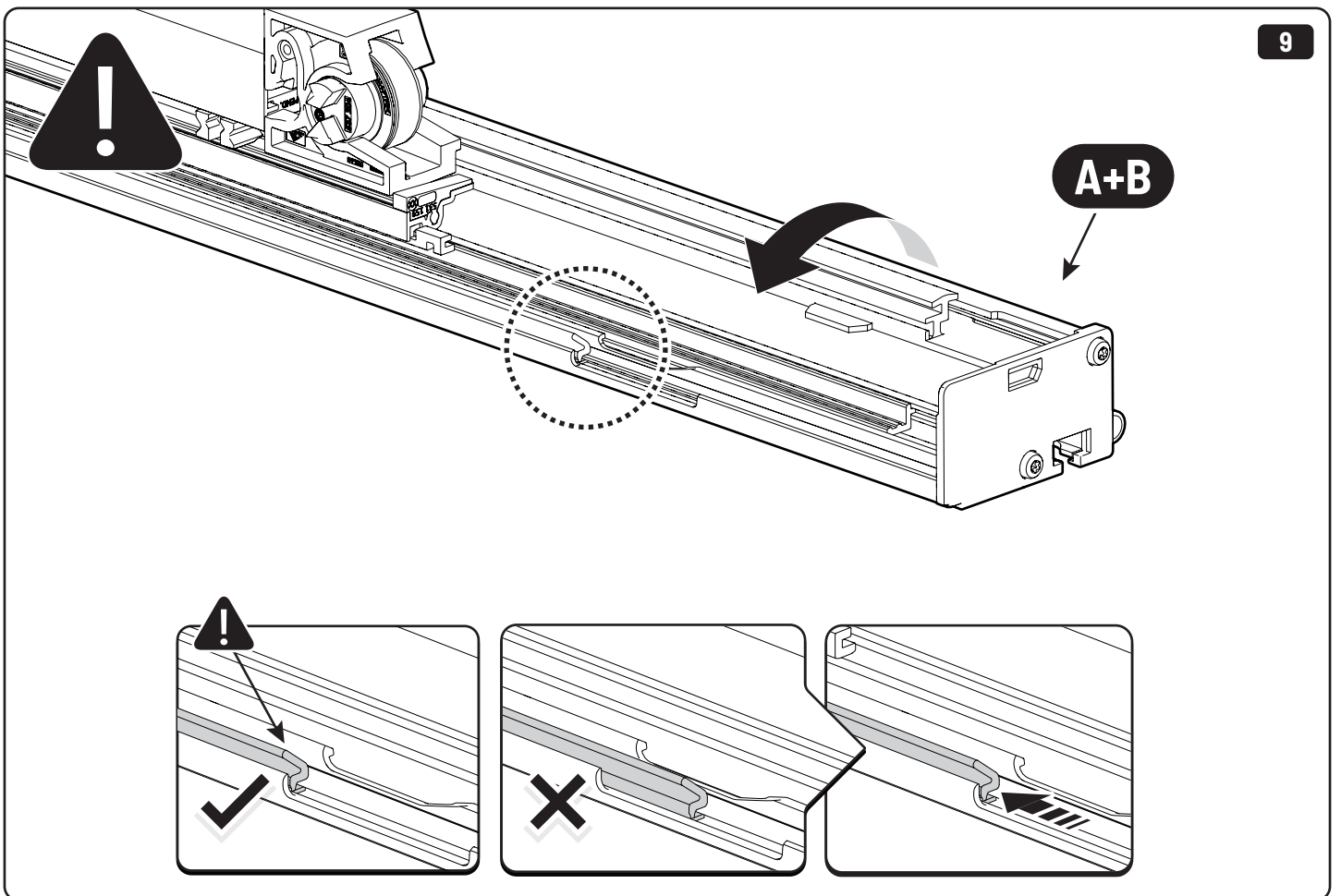
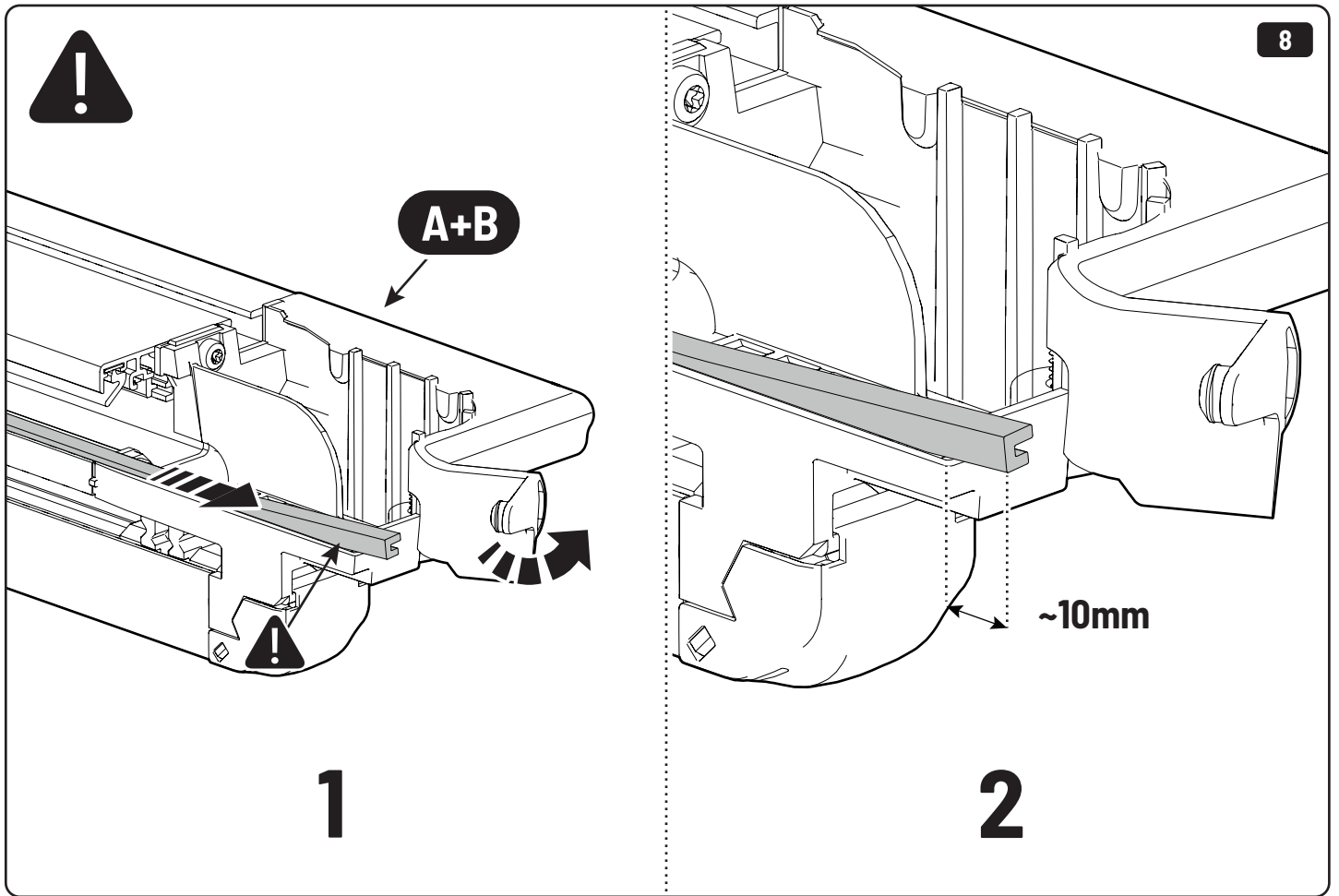

! ONLY FOR DOUBLE CAB

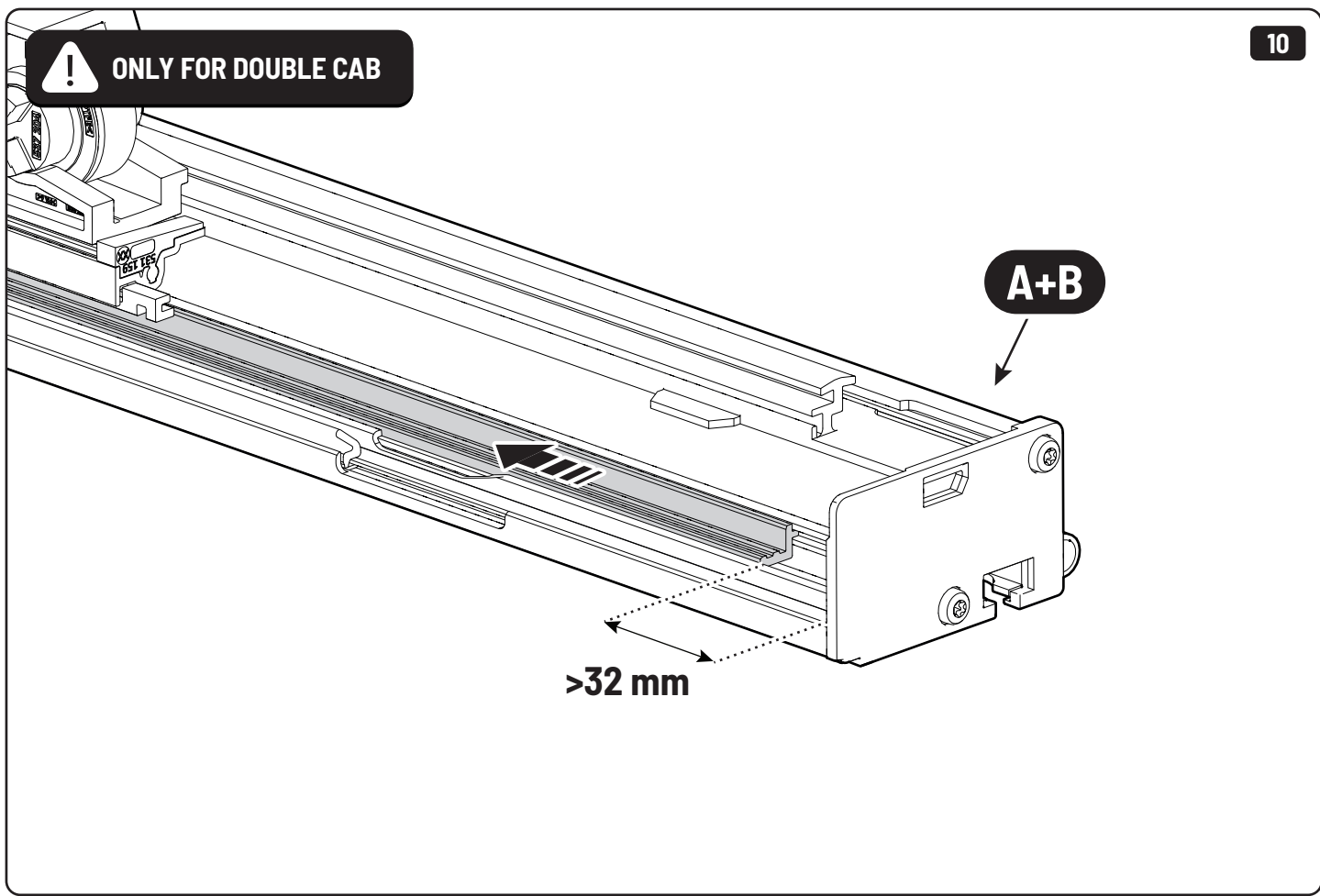

! ONLY FOR RAP CAB

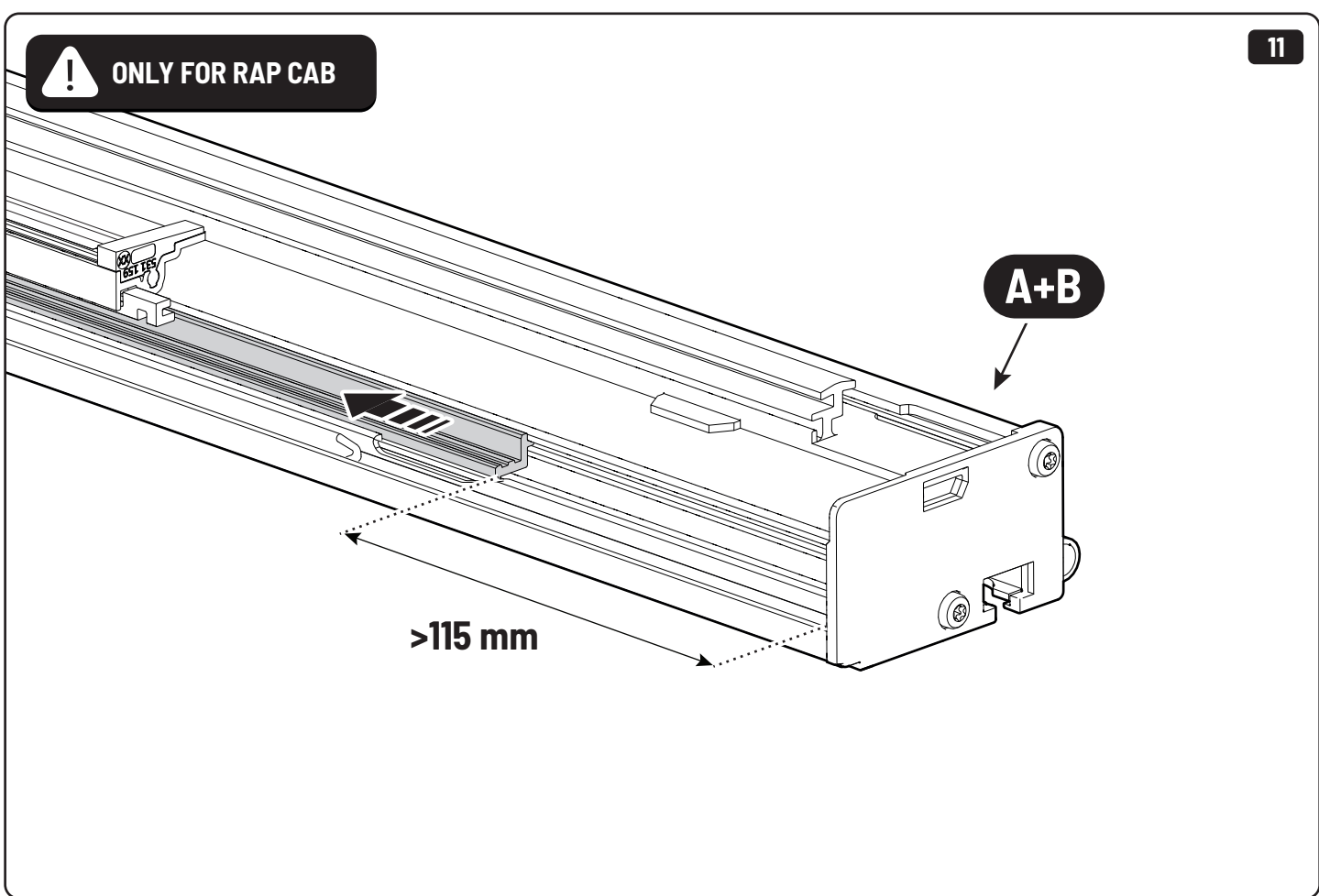

! Rap Cab: **W** x3

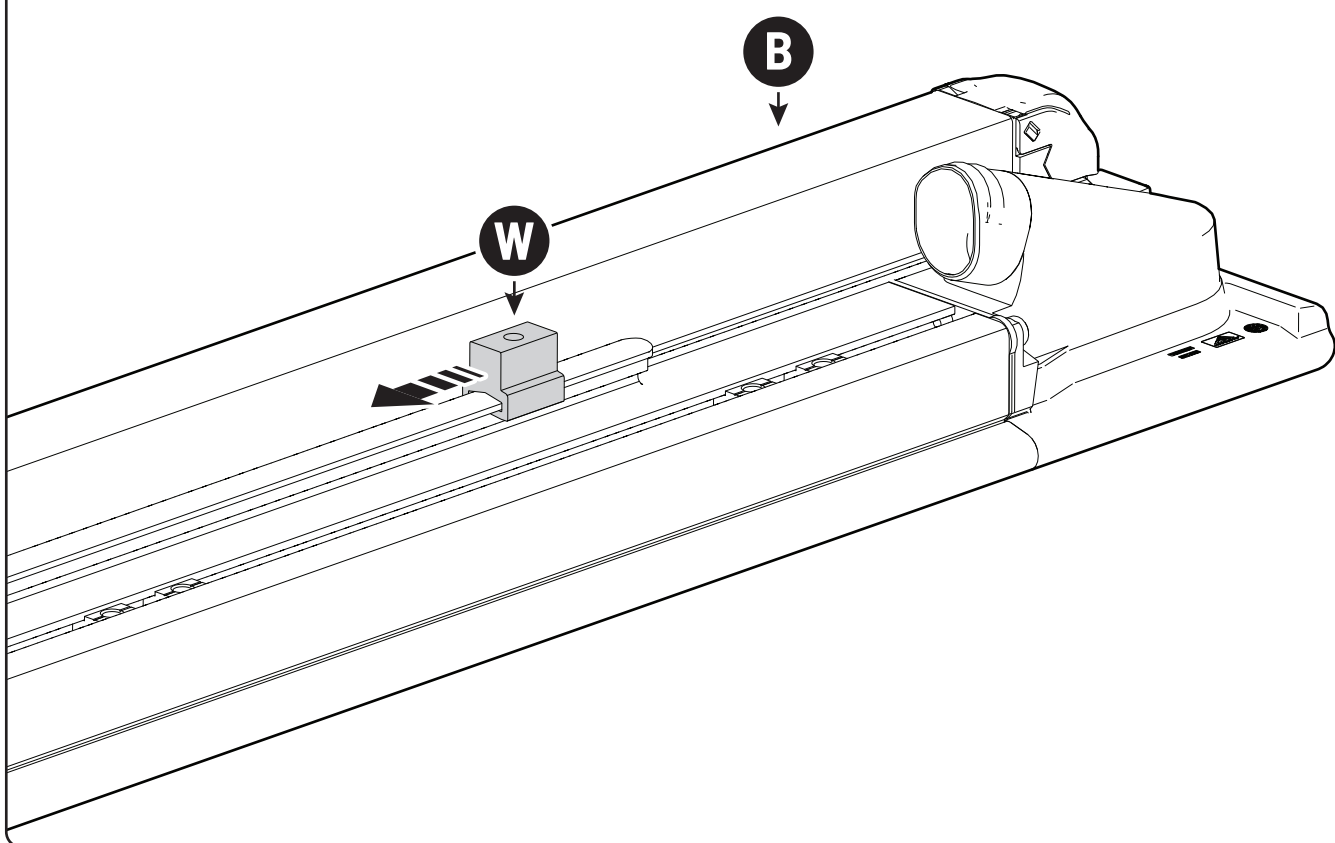
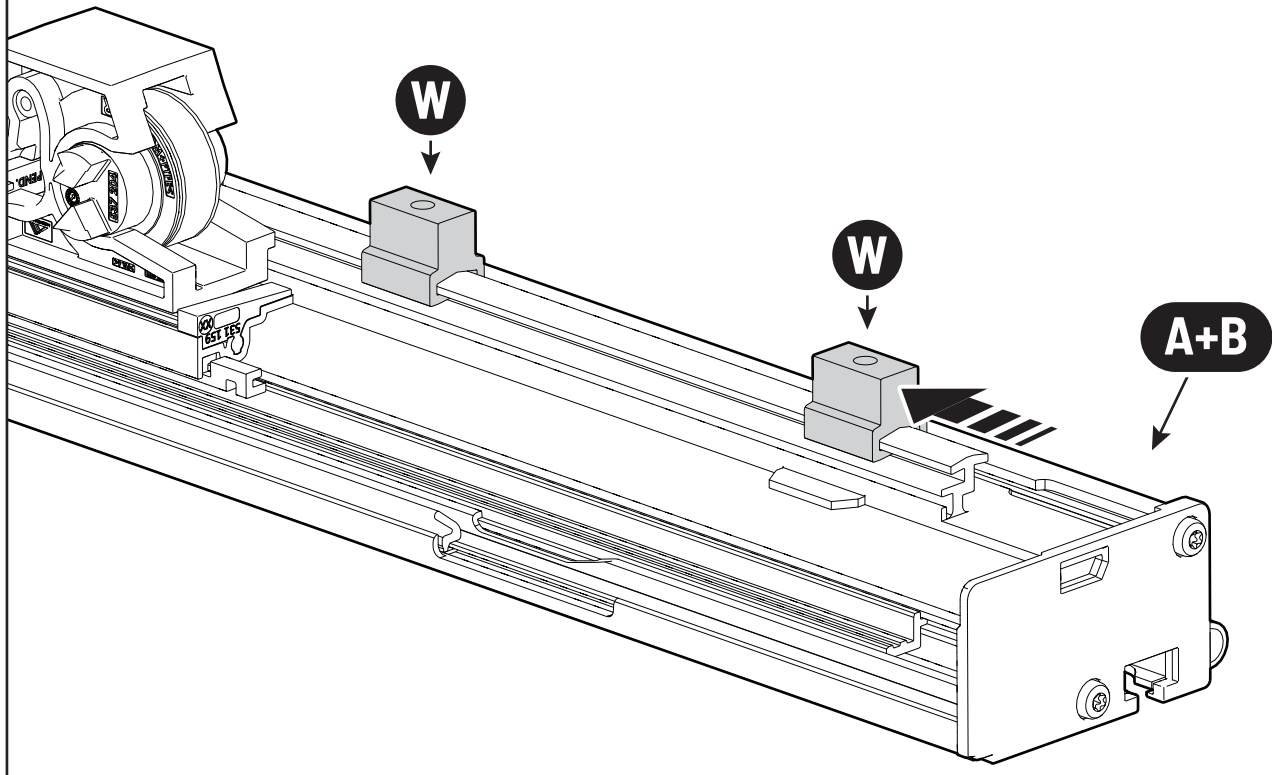

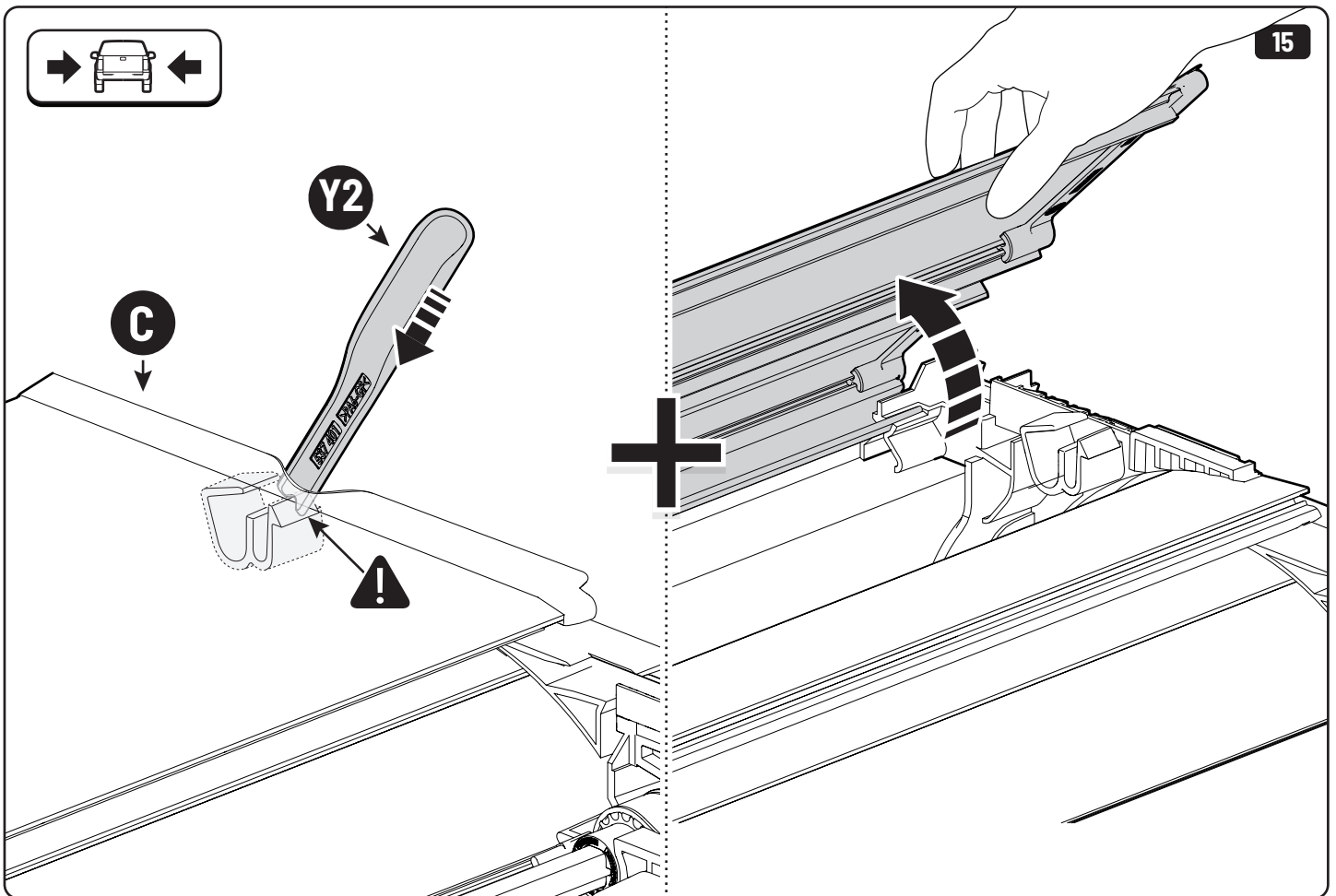
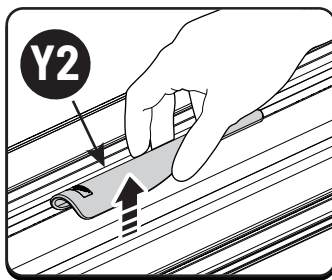
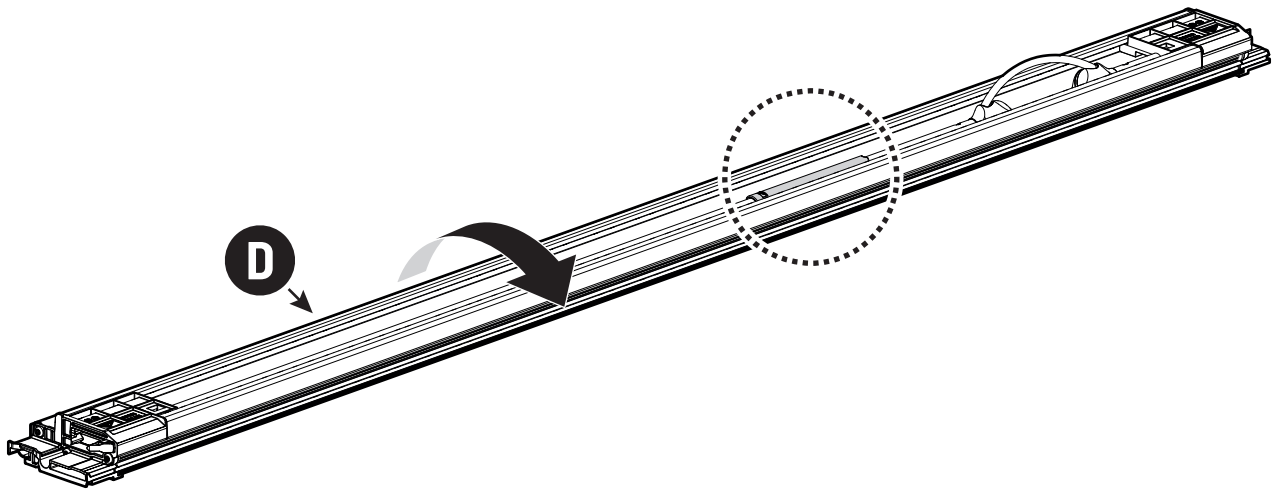

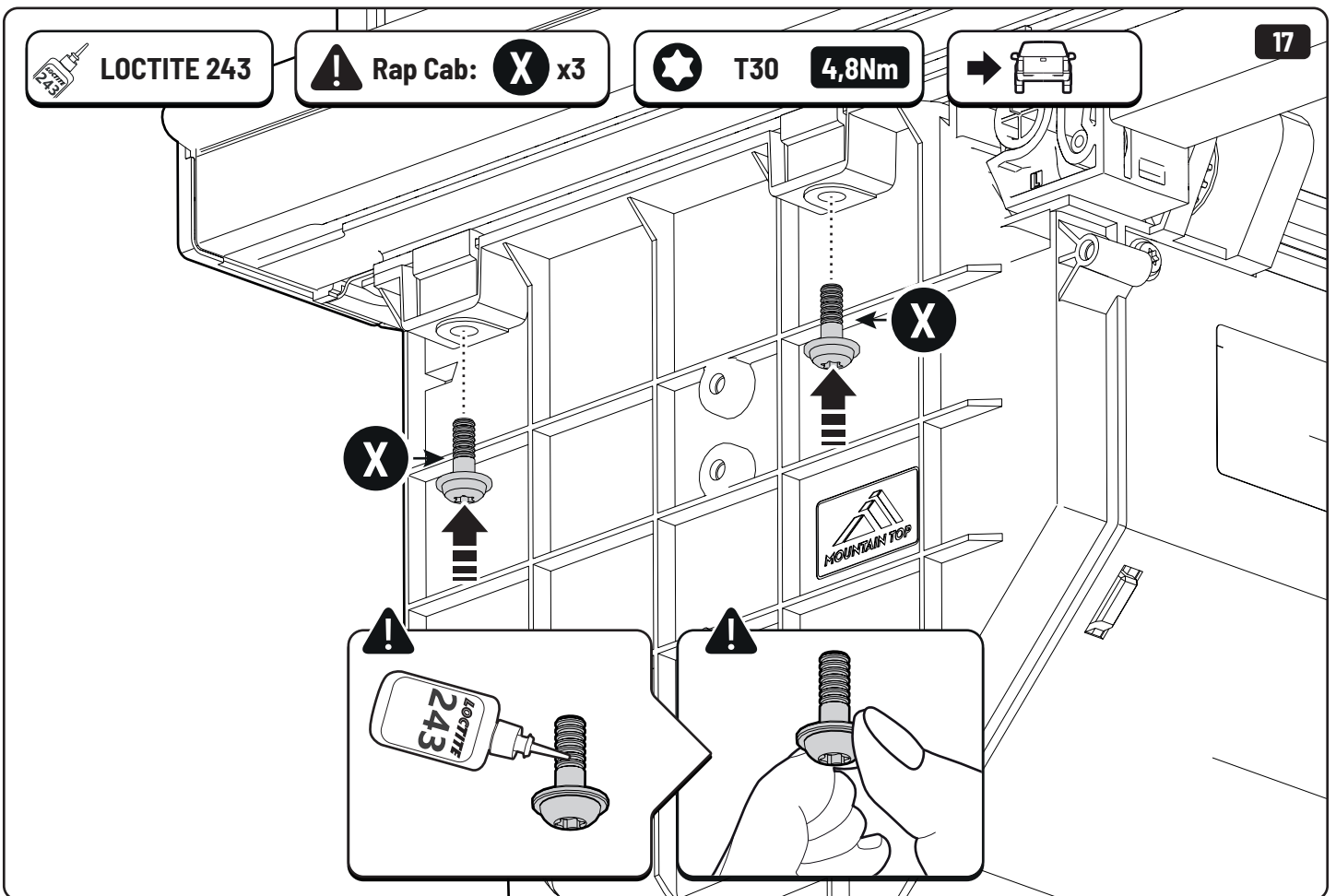
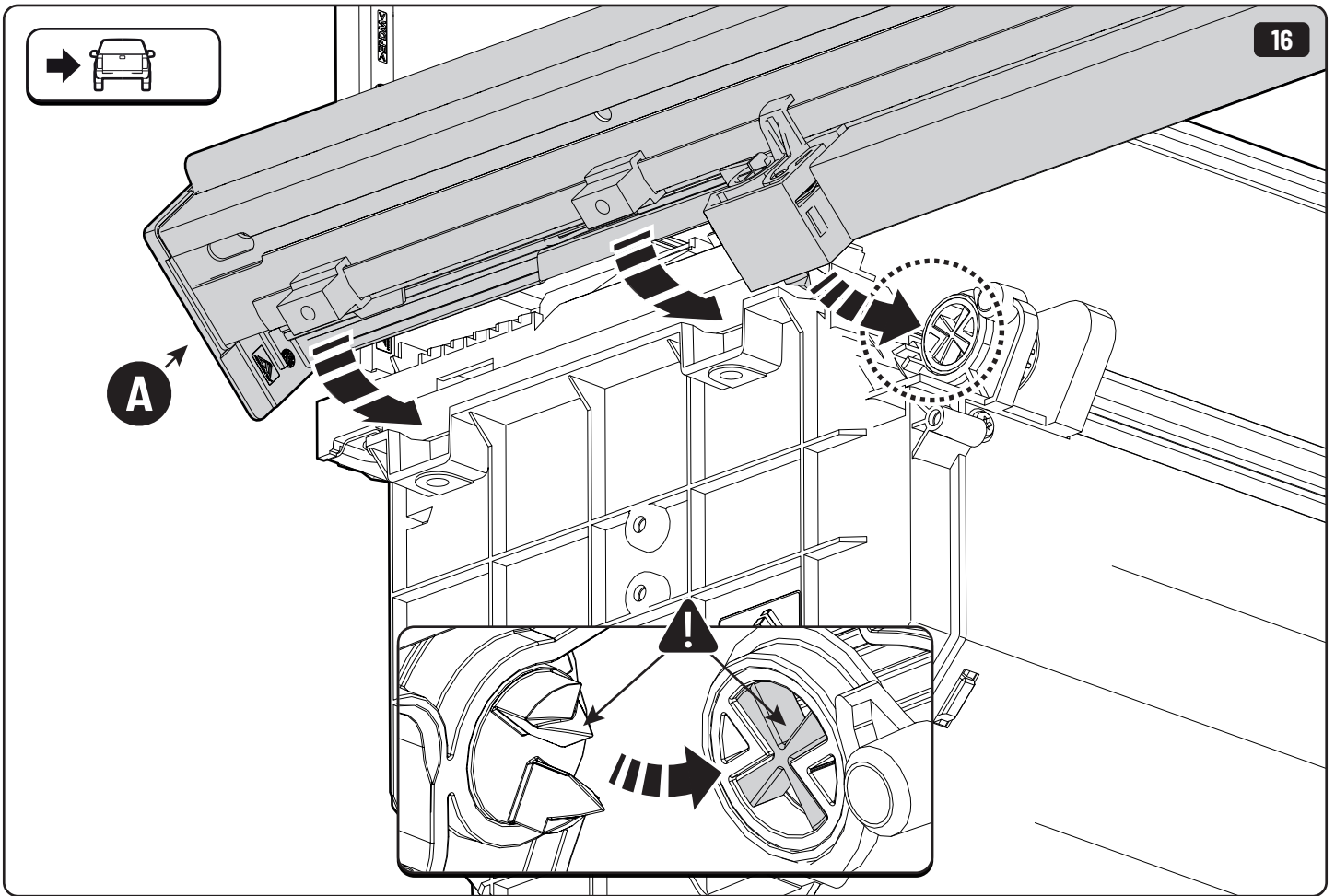



B
↓

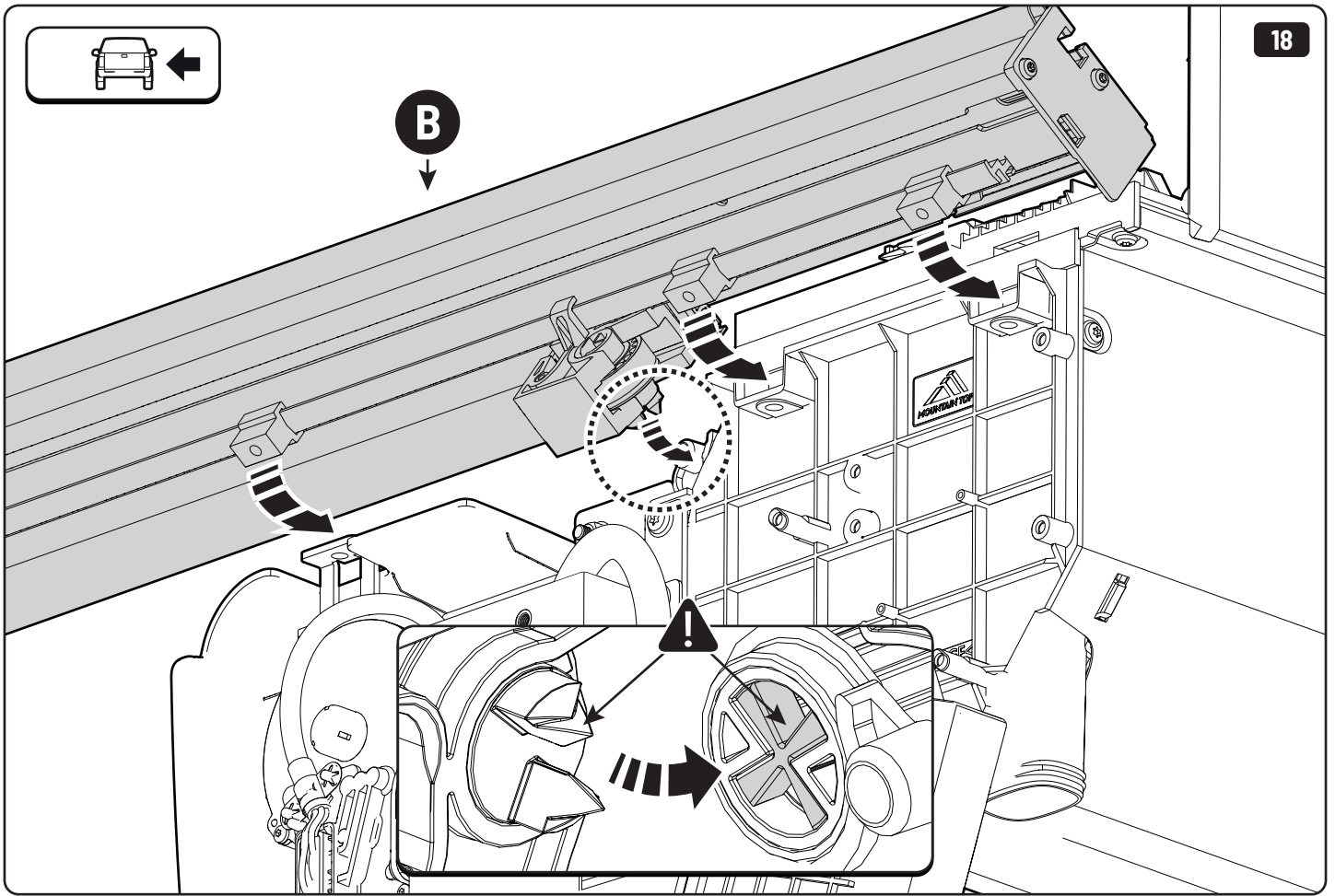

 **LOCTITE 243**

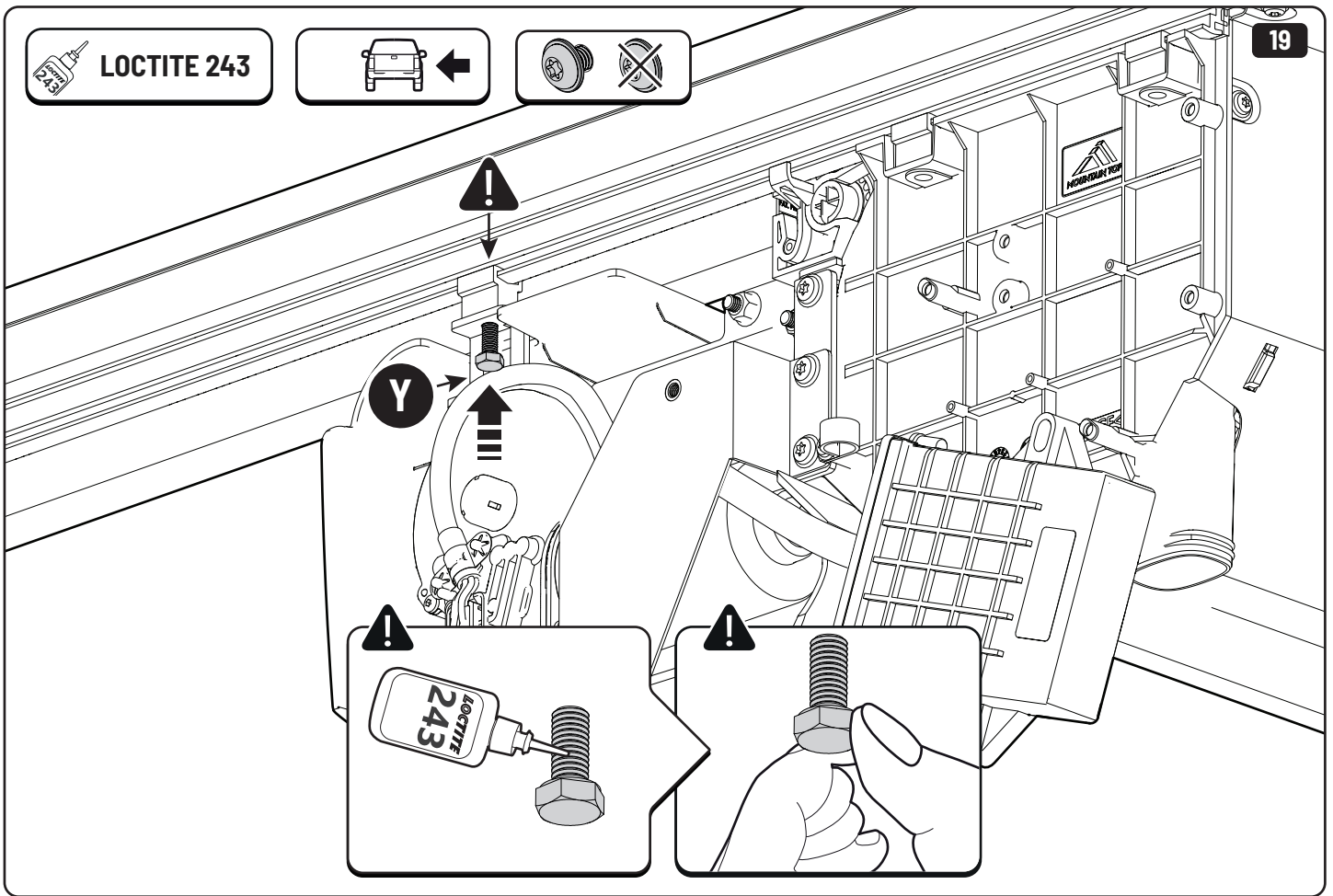

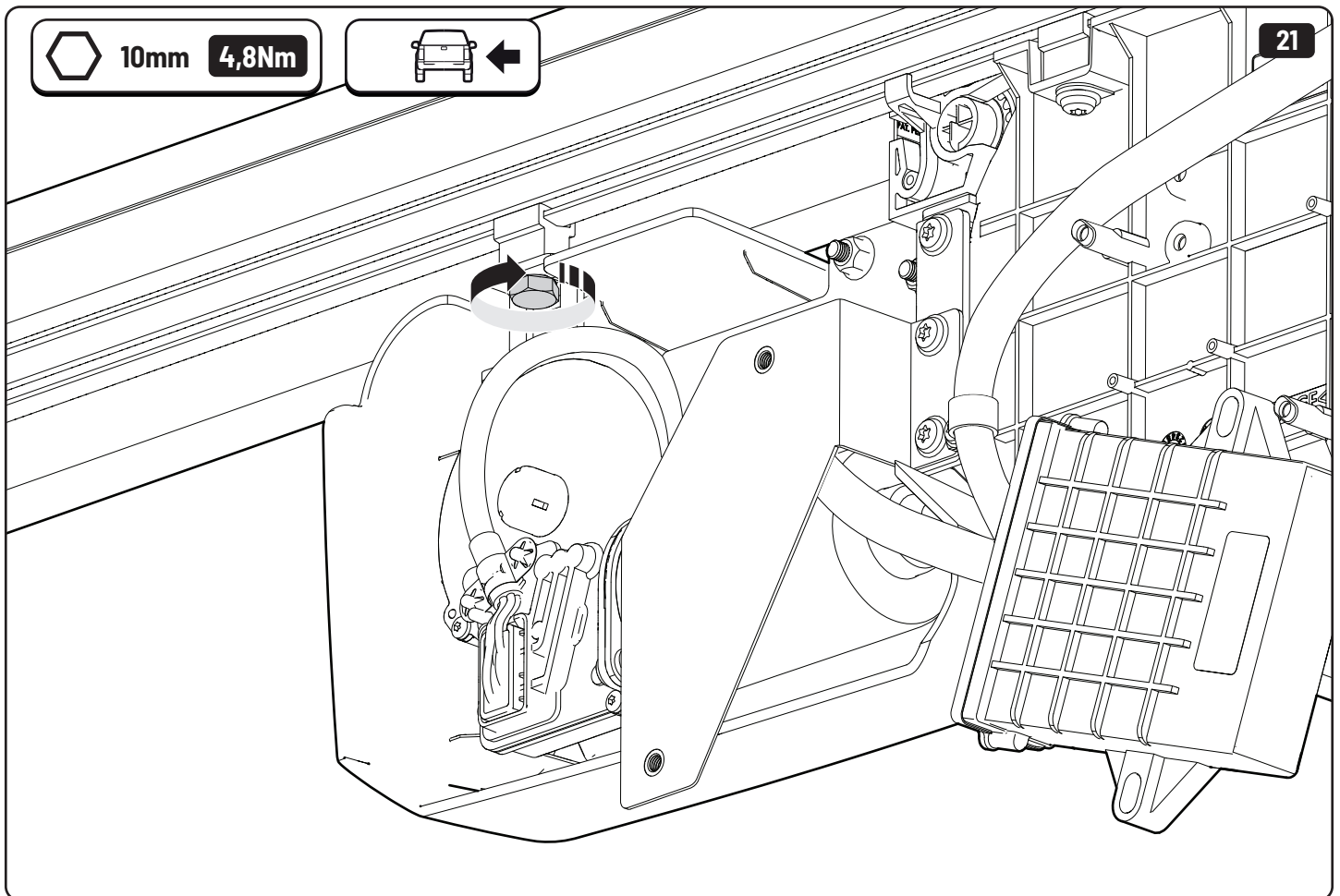
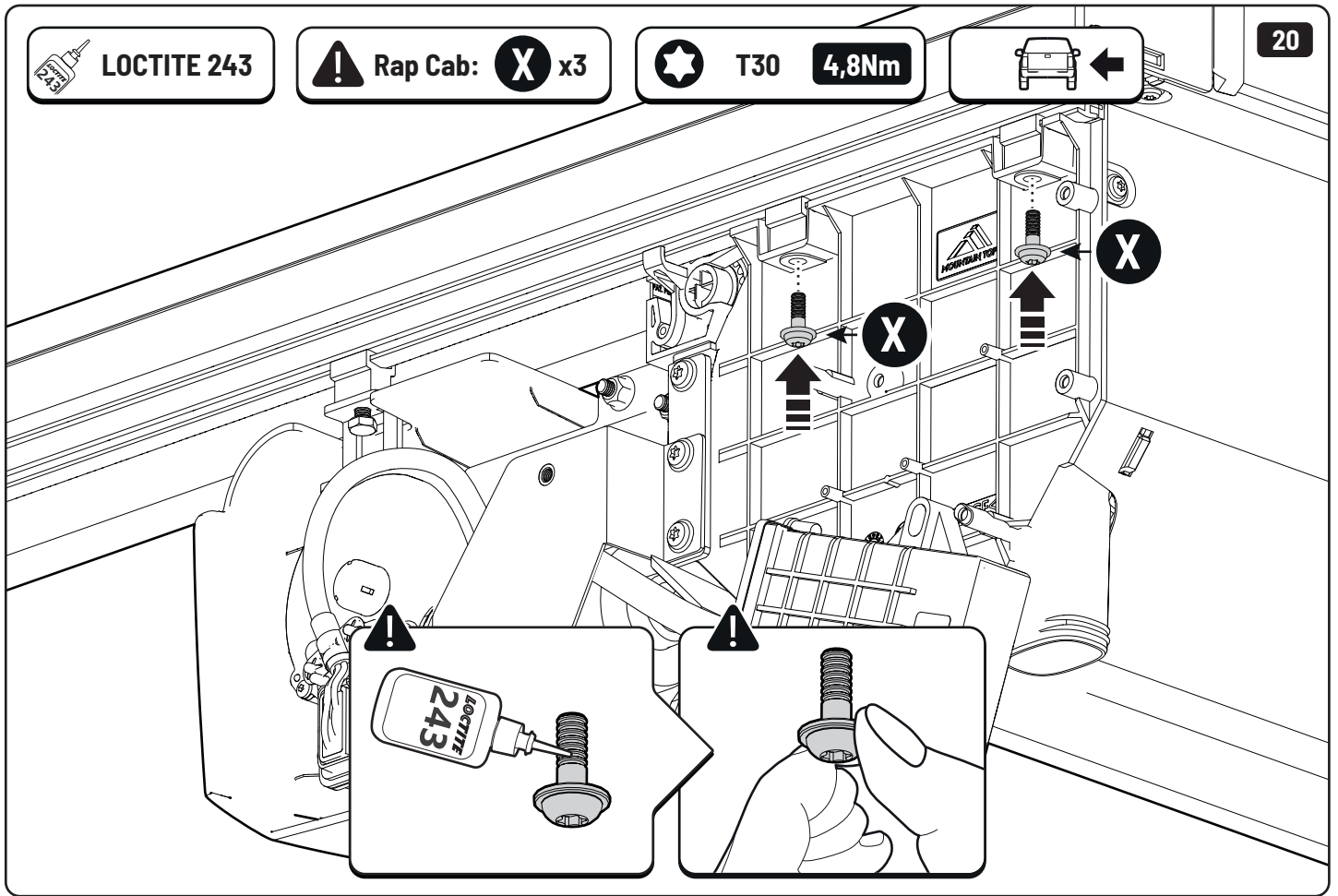

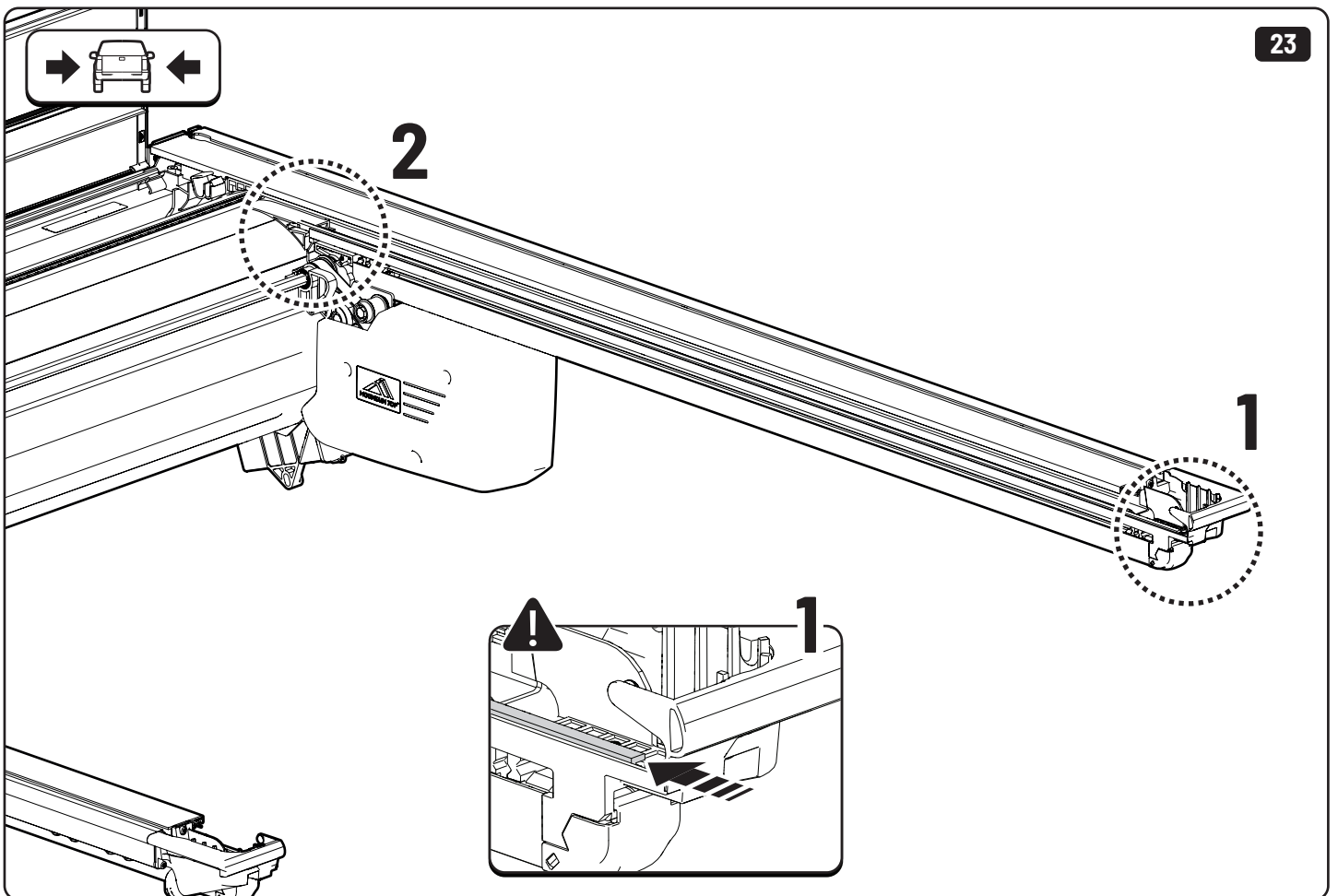
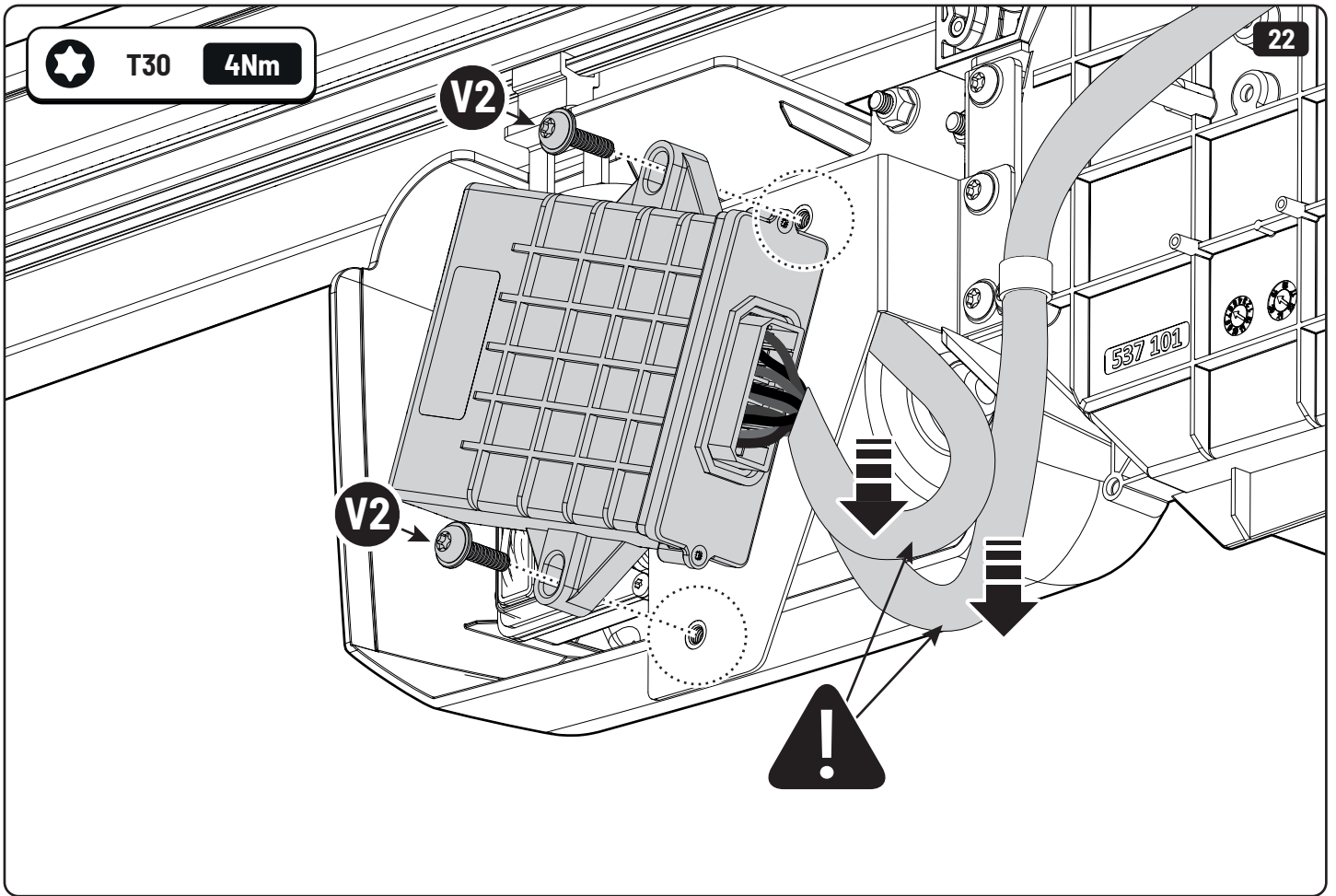

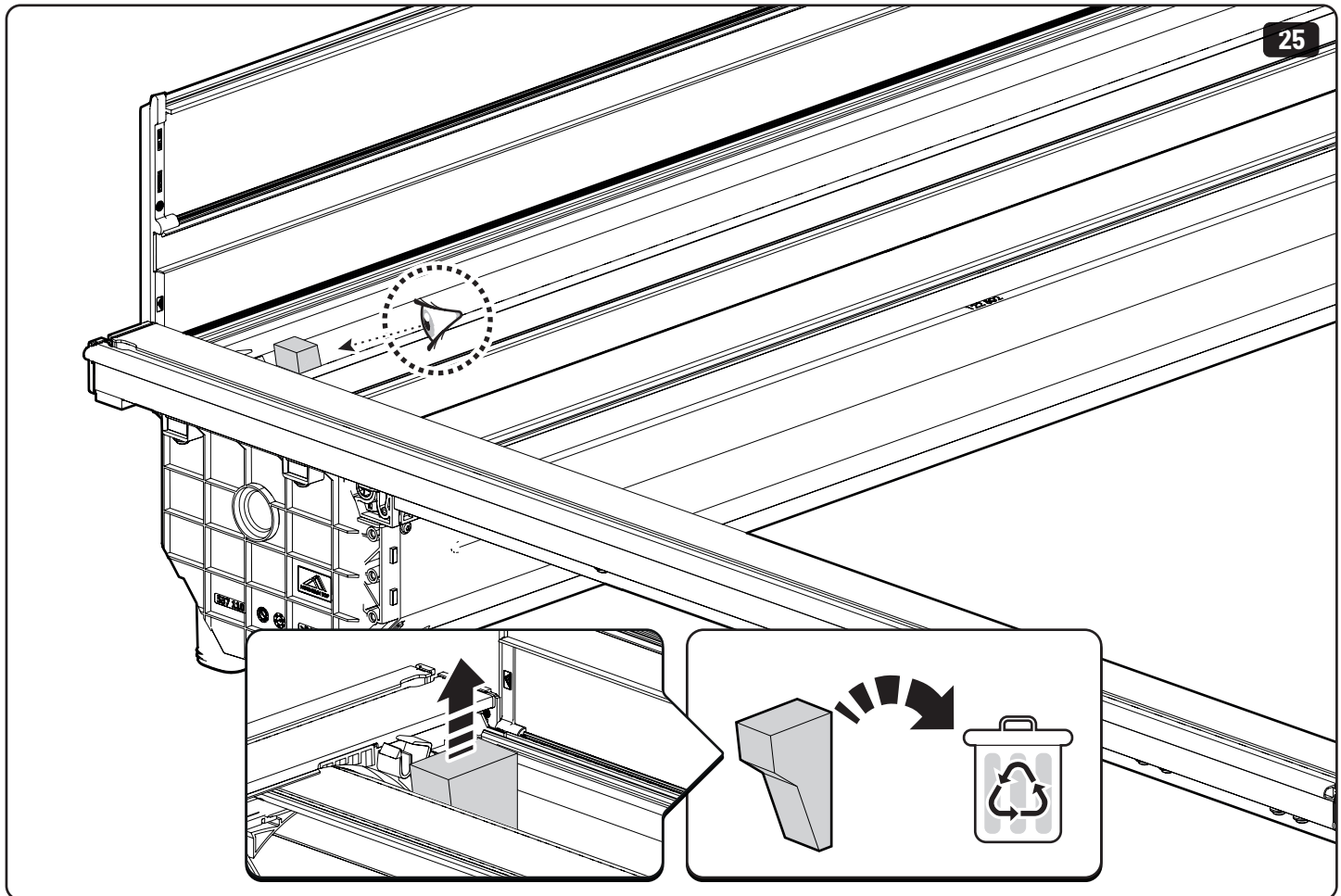
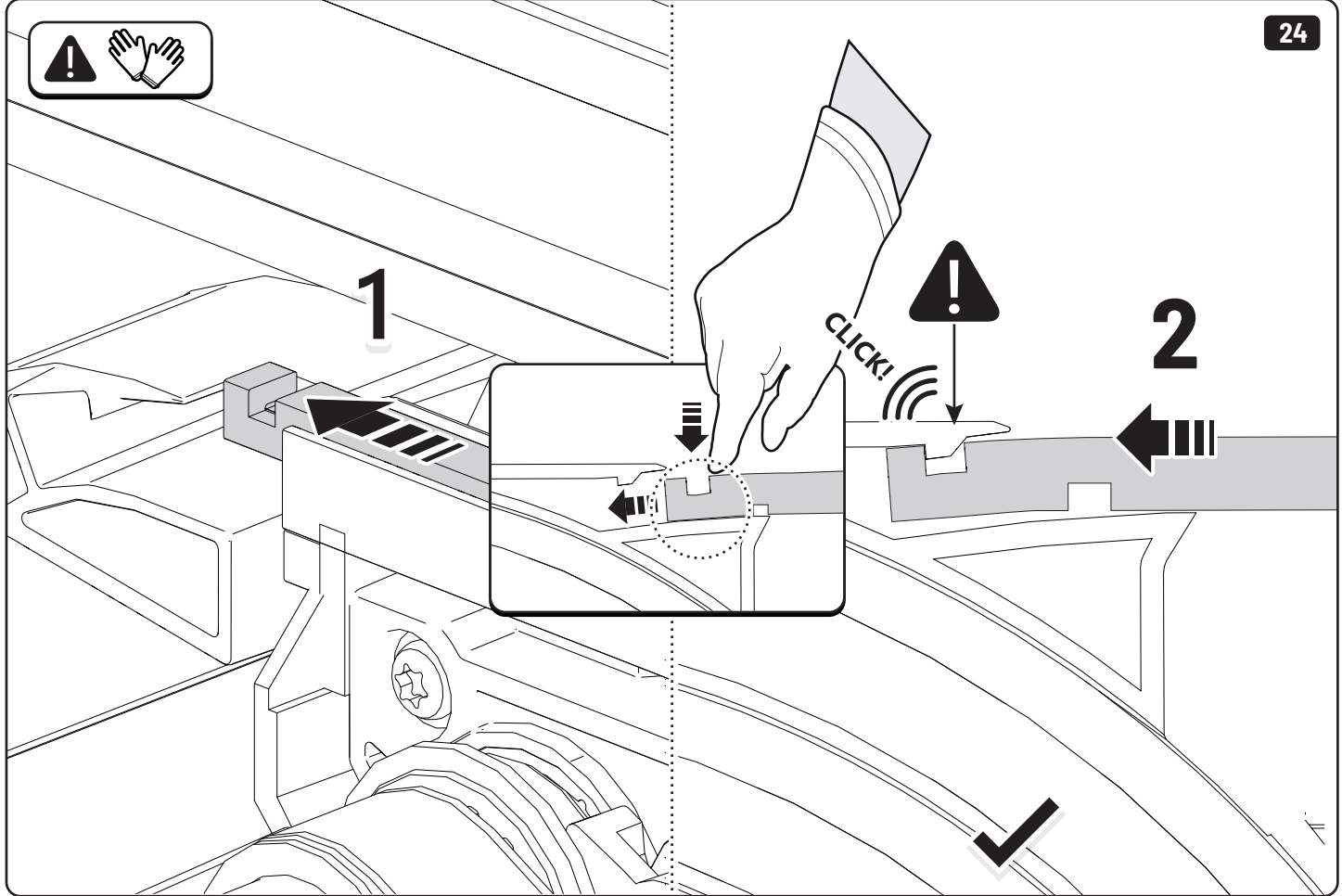

 **RAP CAB**

26

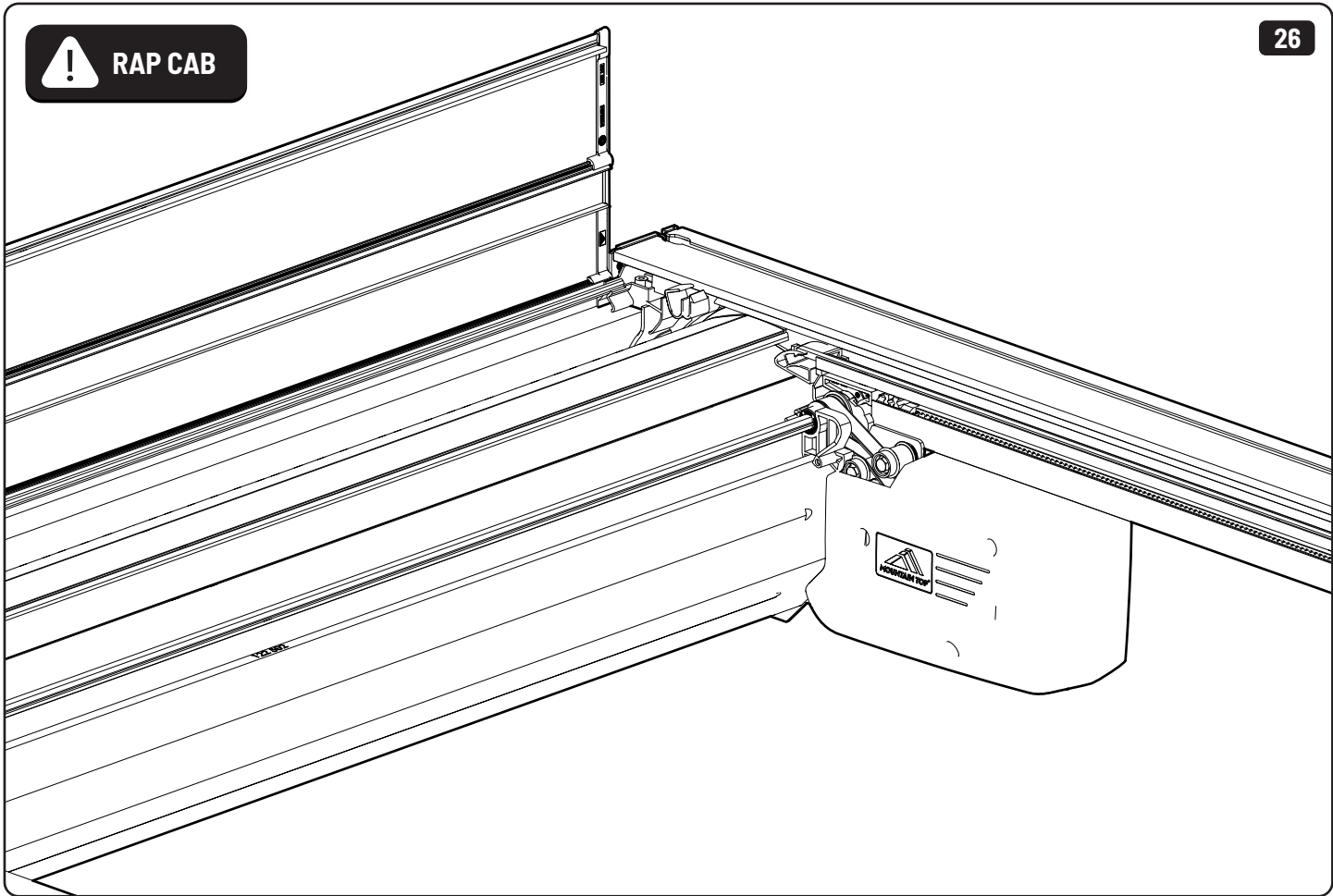

27

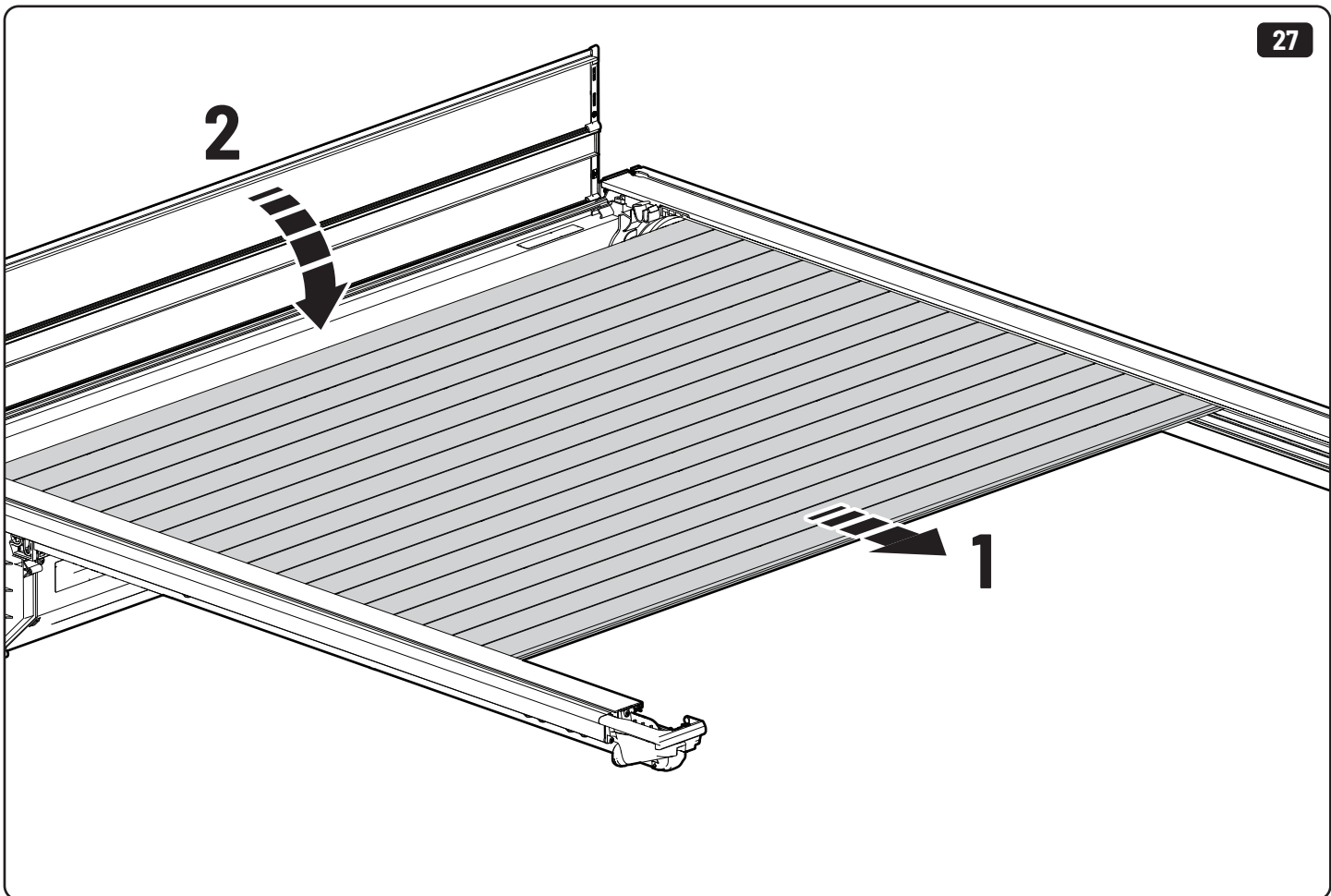

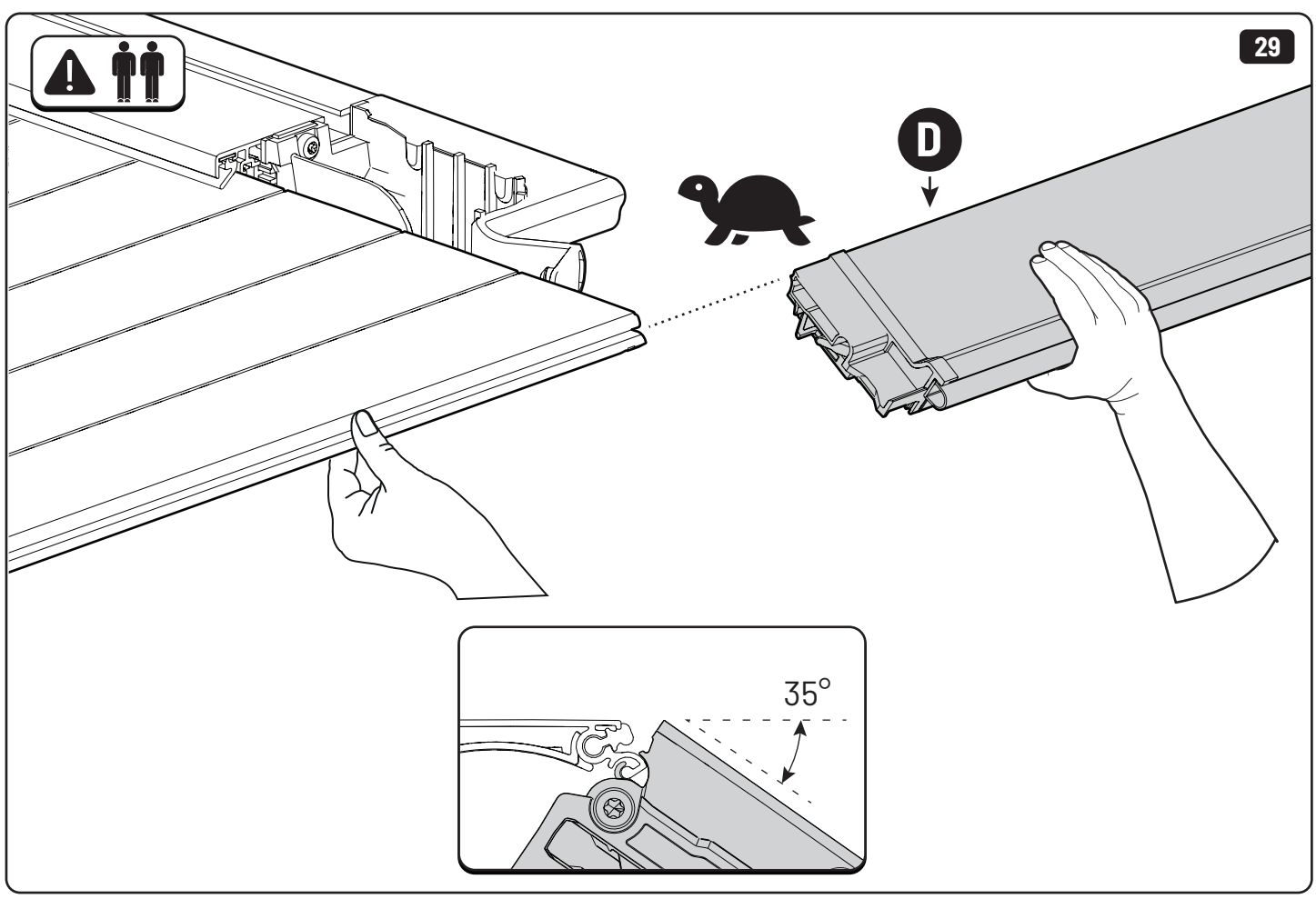
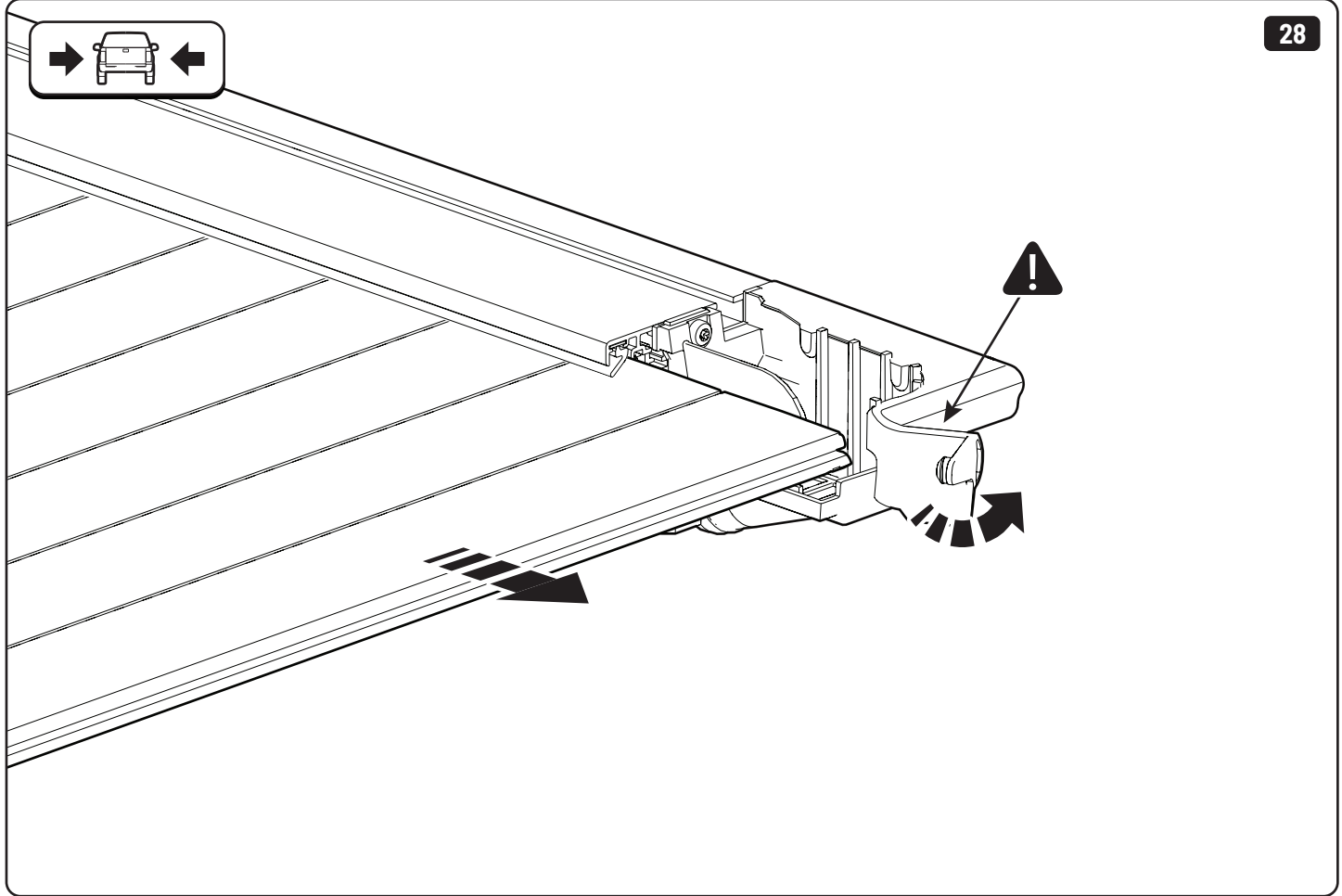

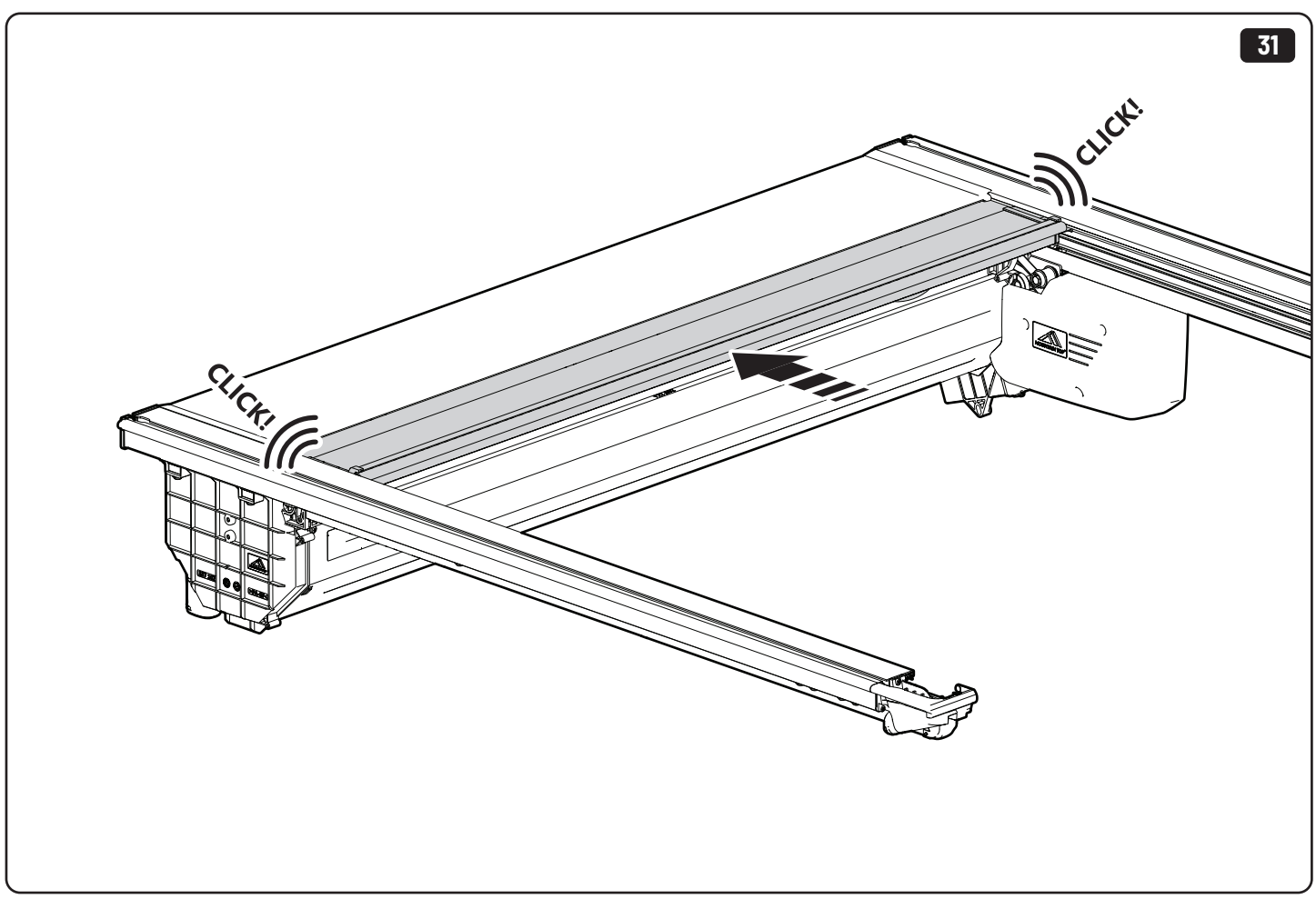
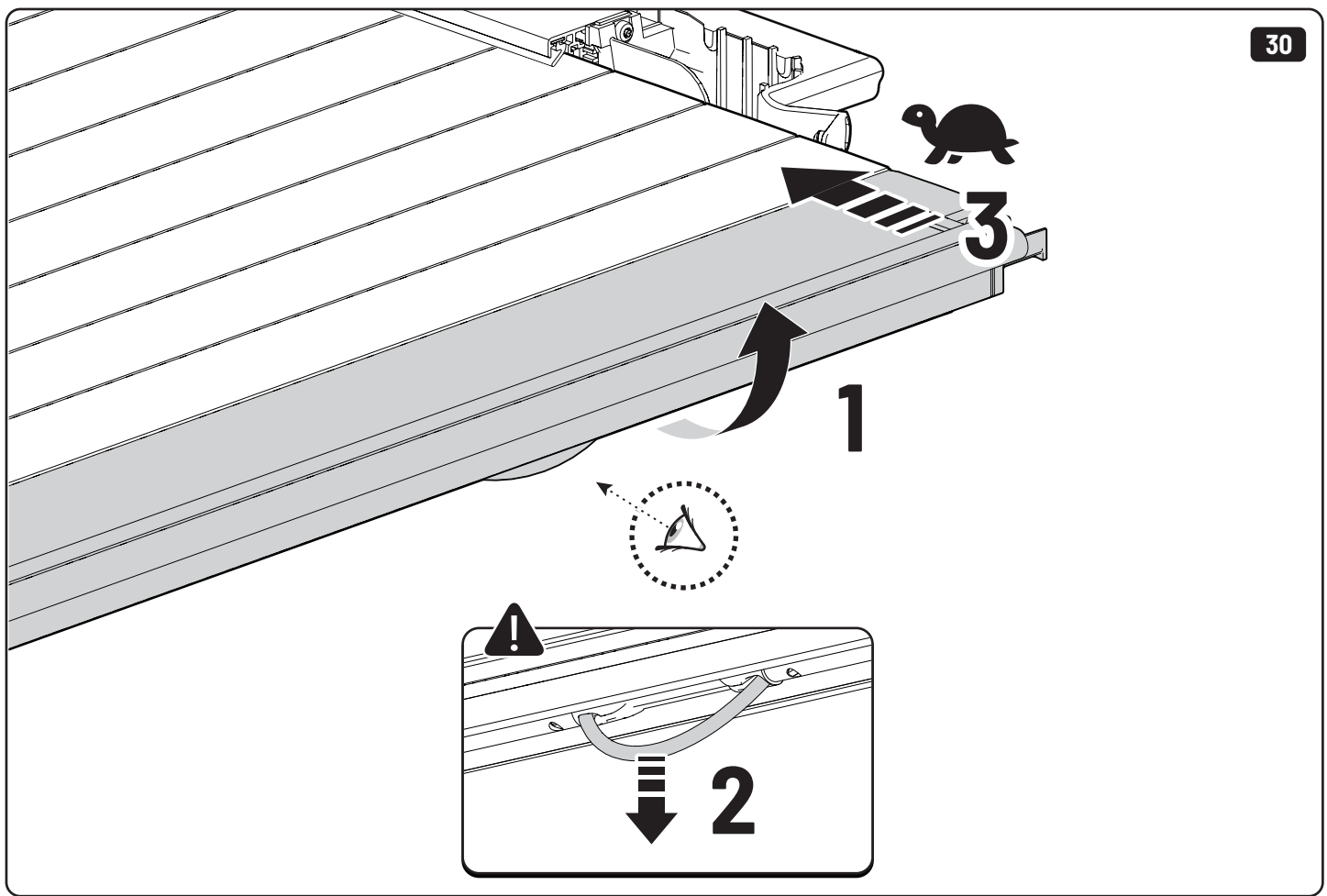

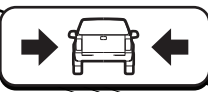
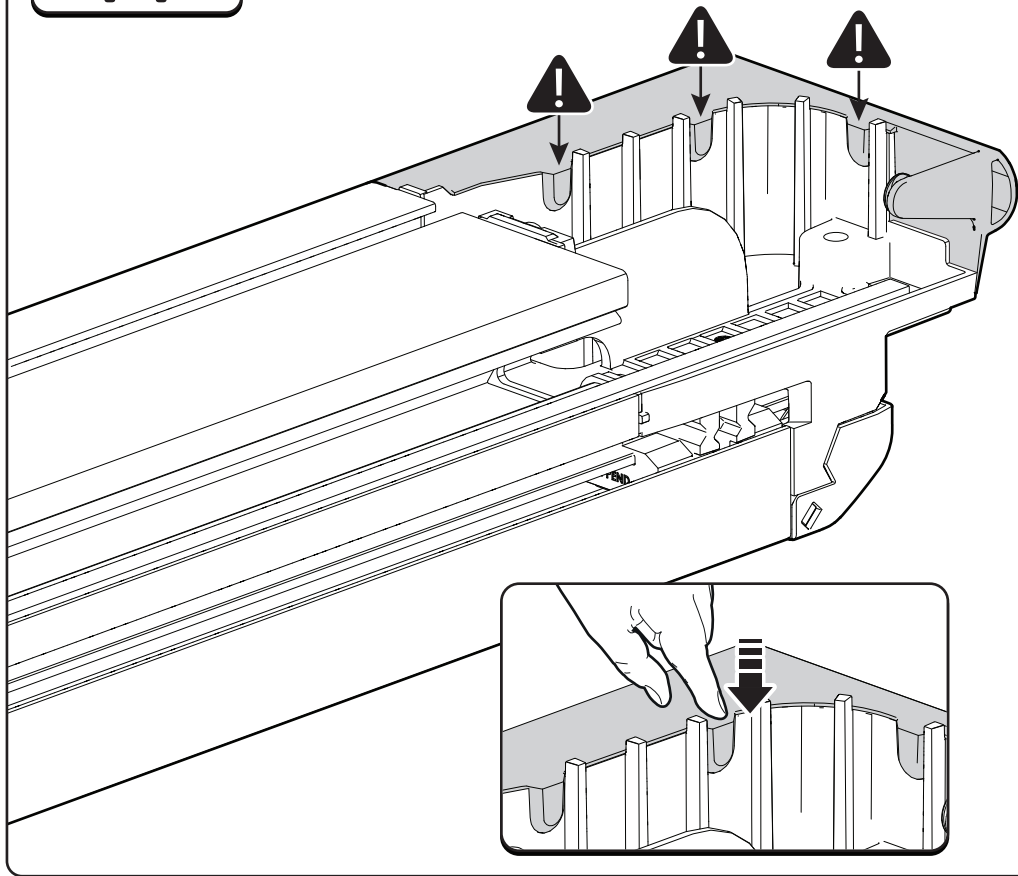
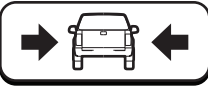

T20 2,4Nm

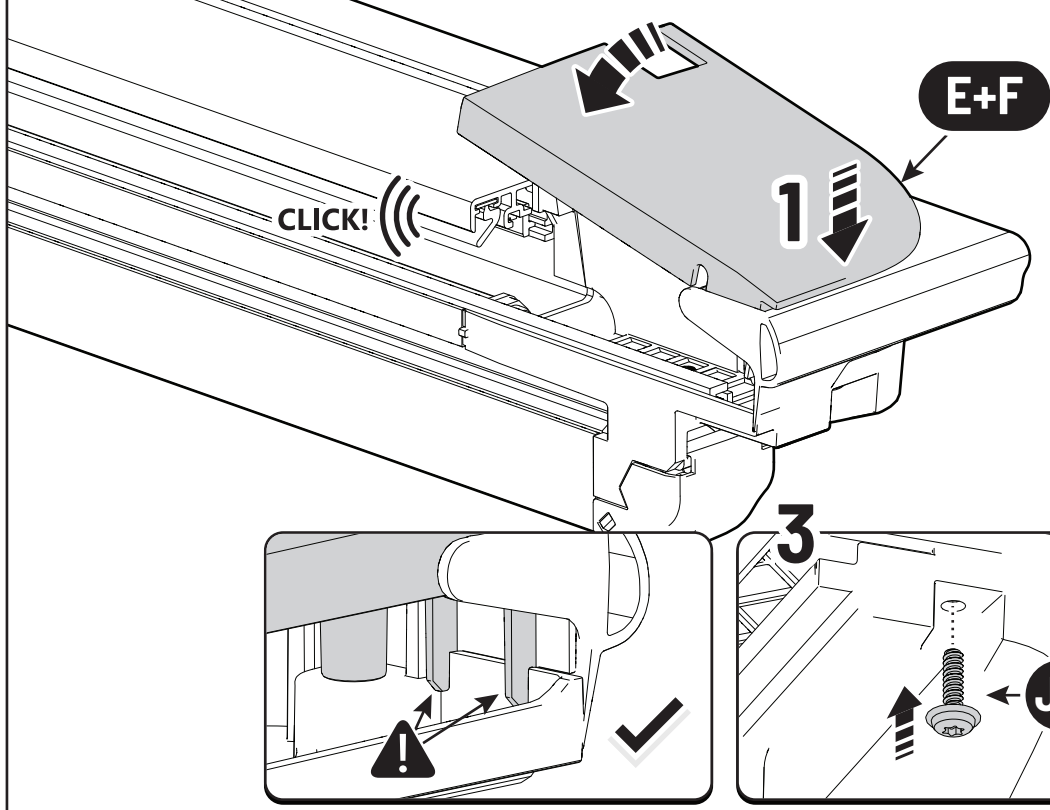

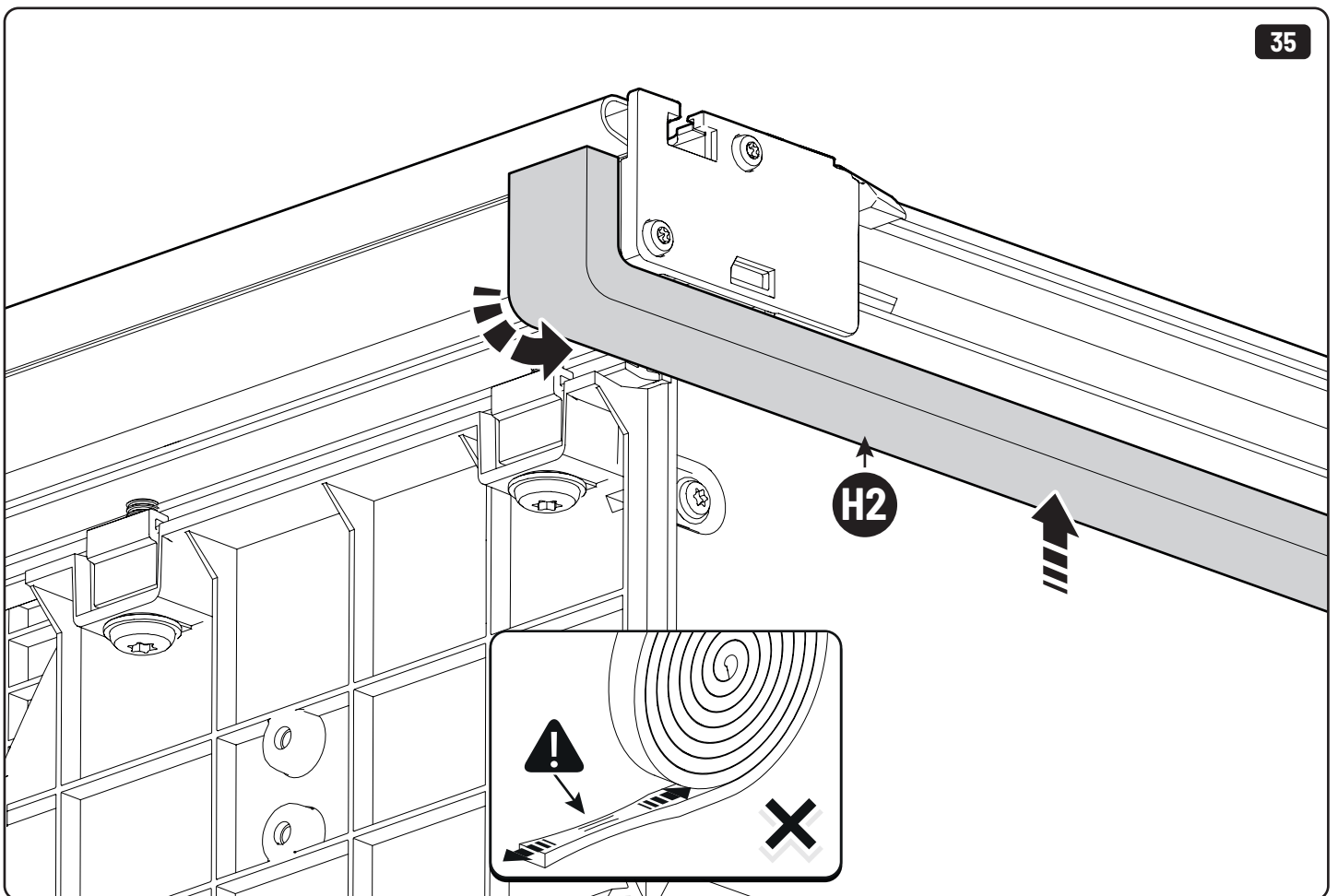
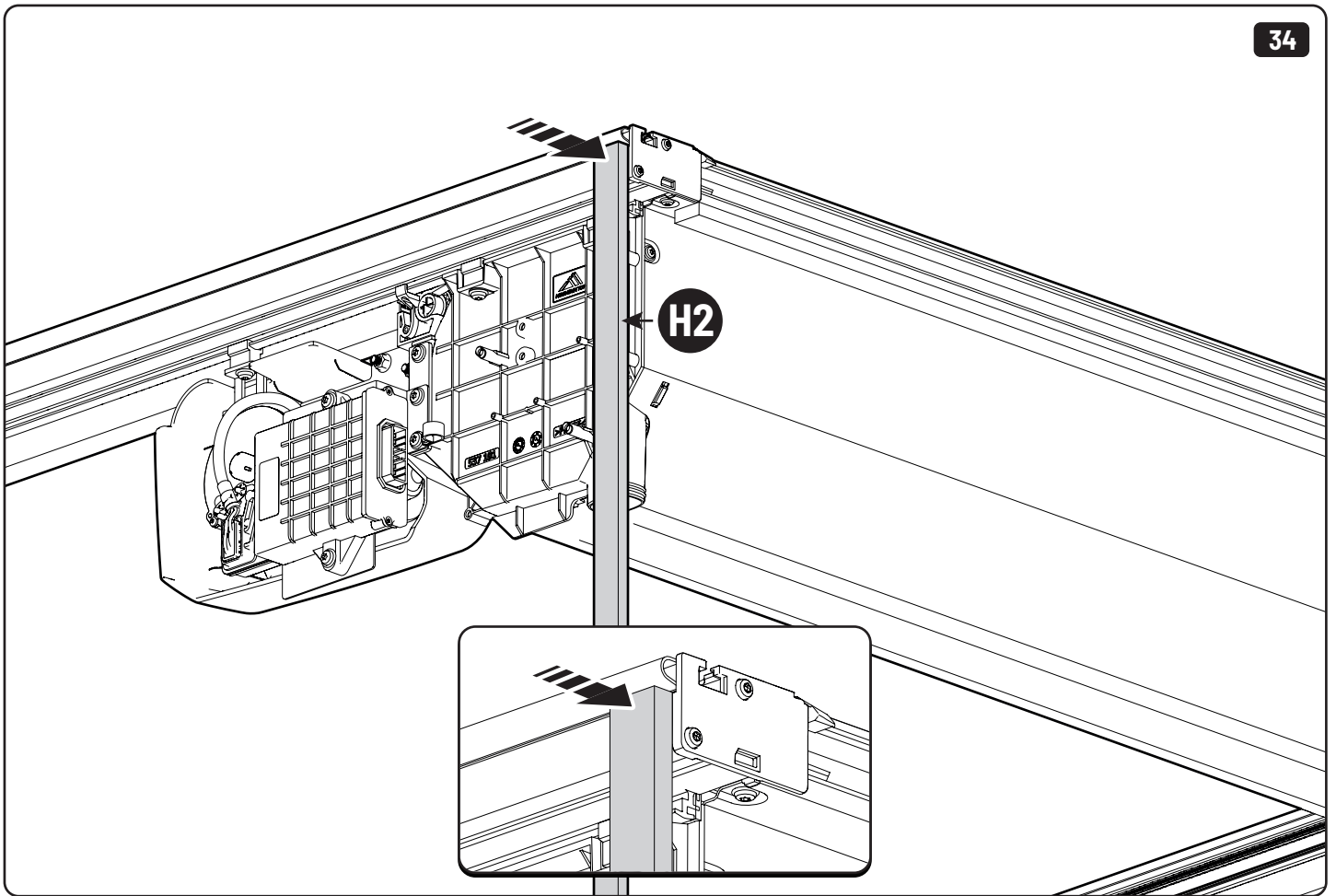

1

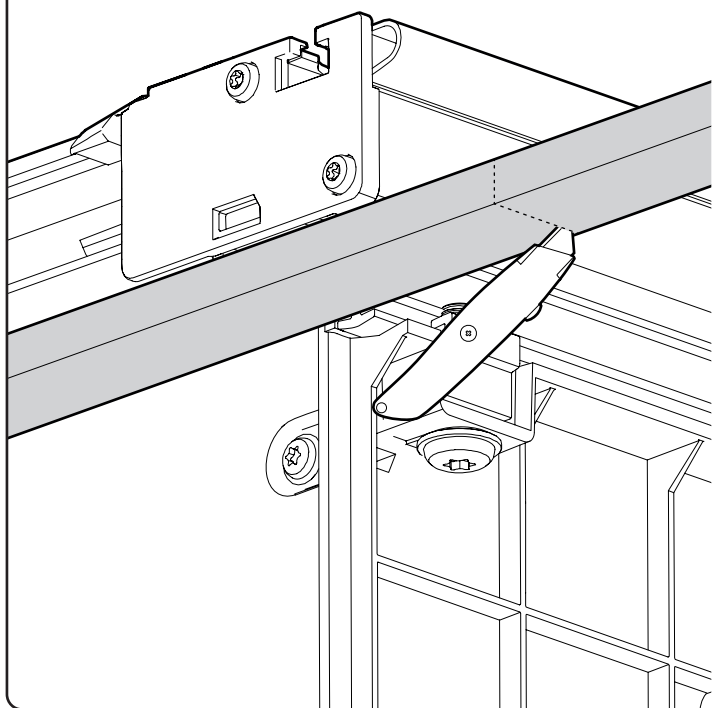

2

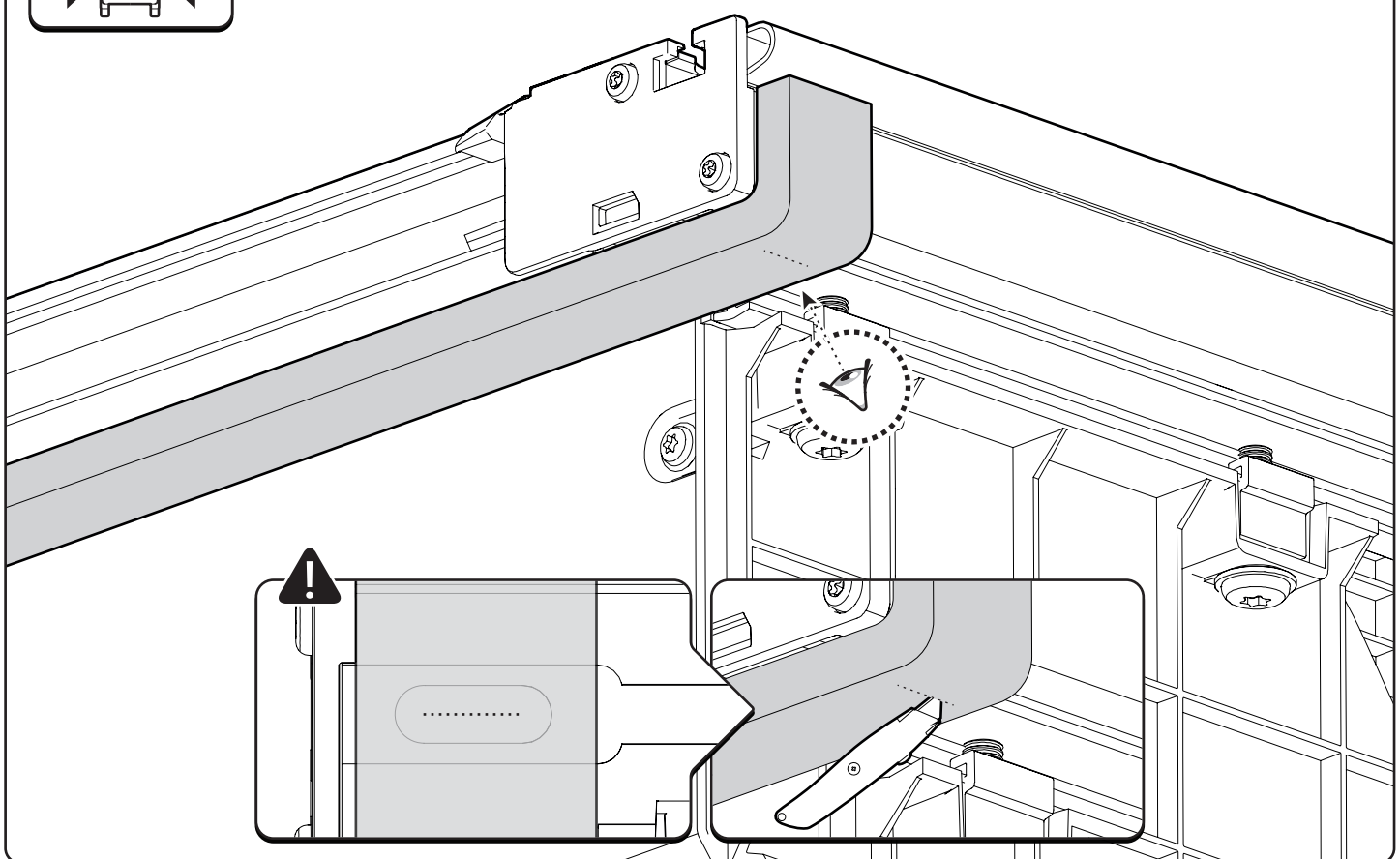
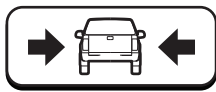
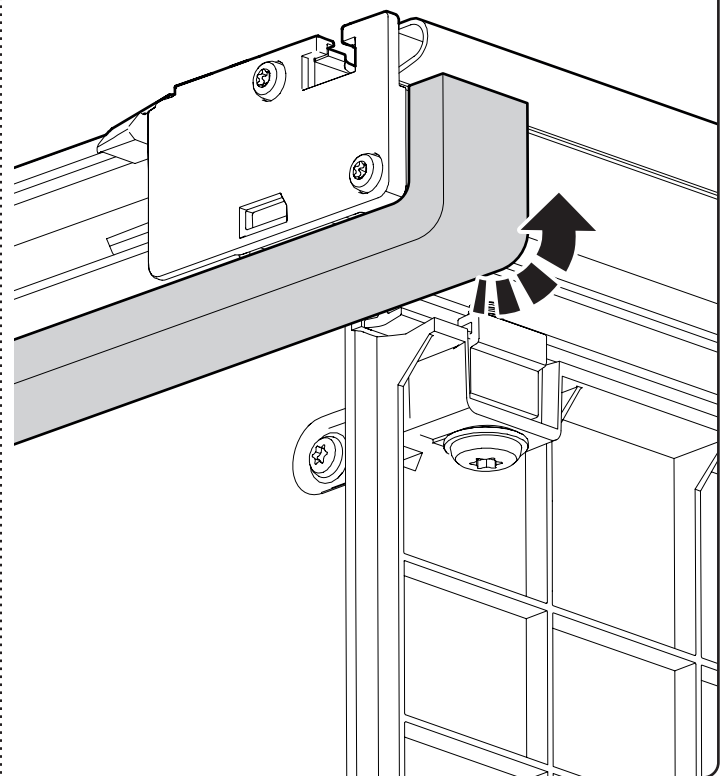

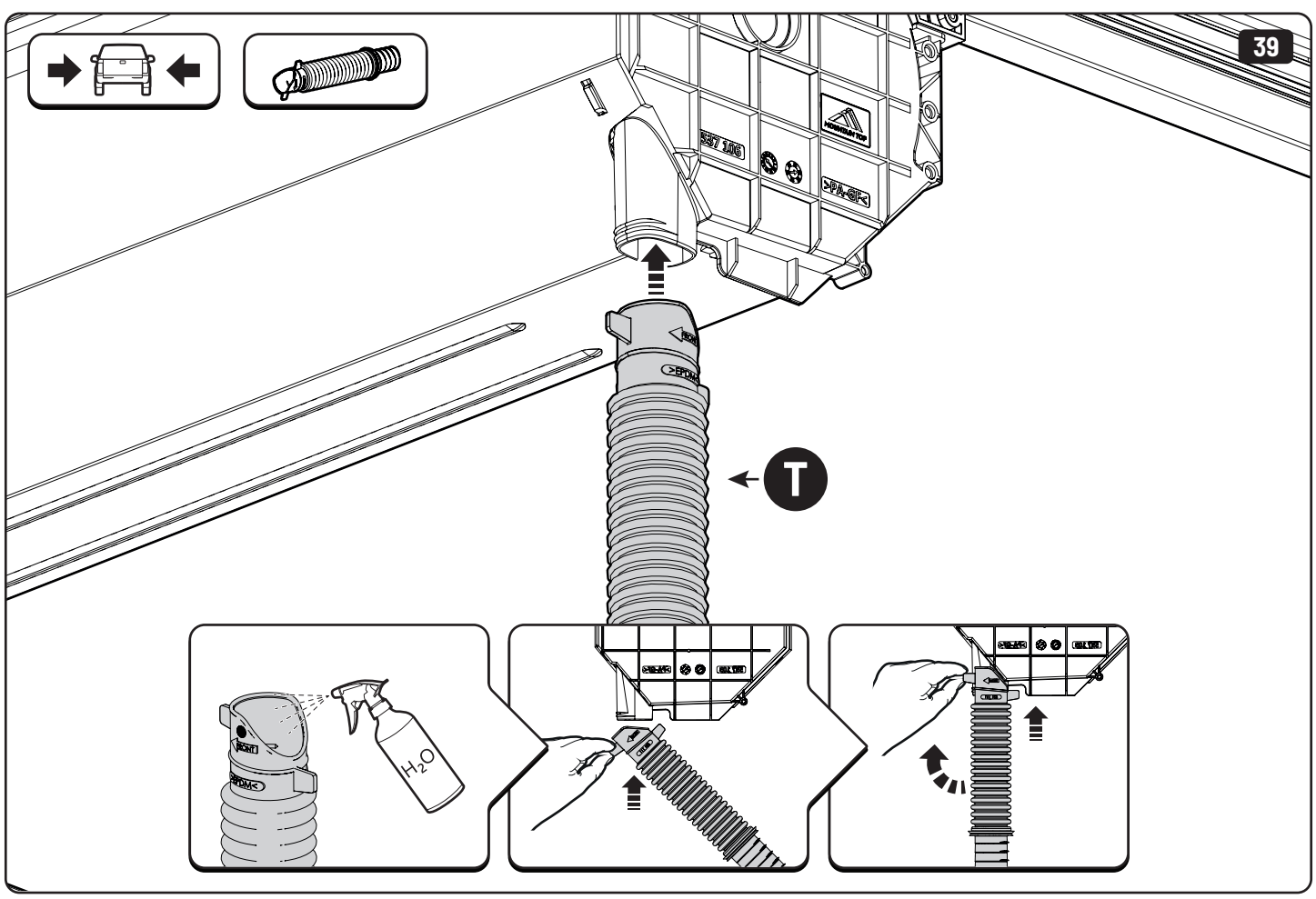
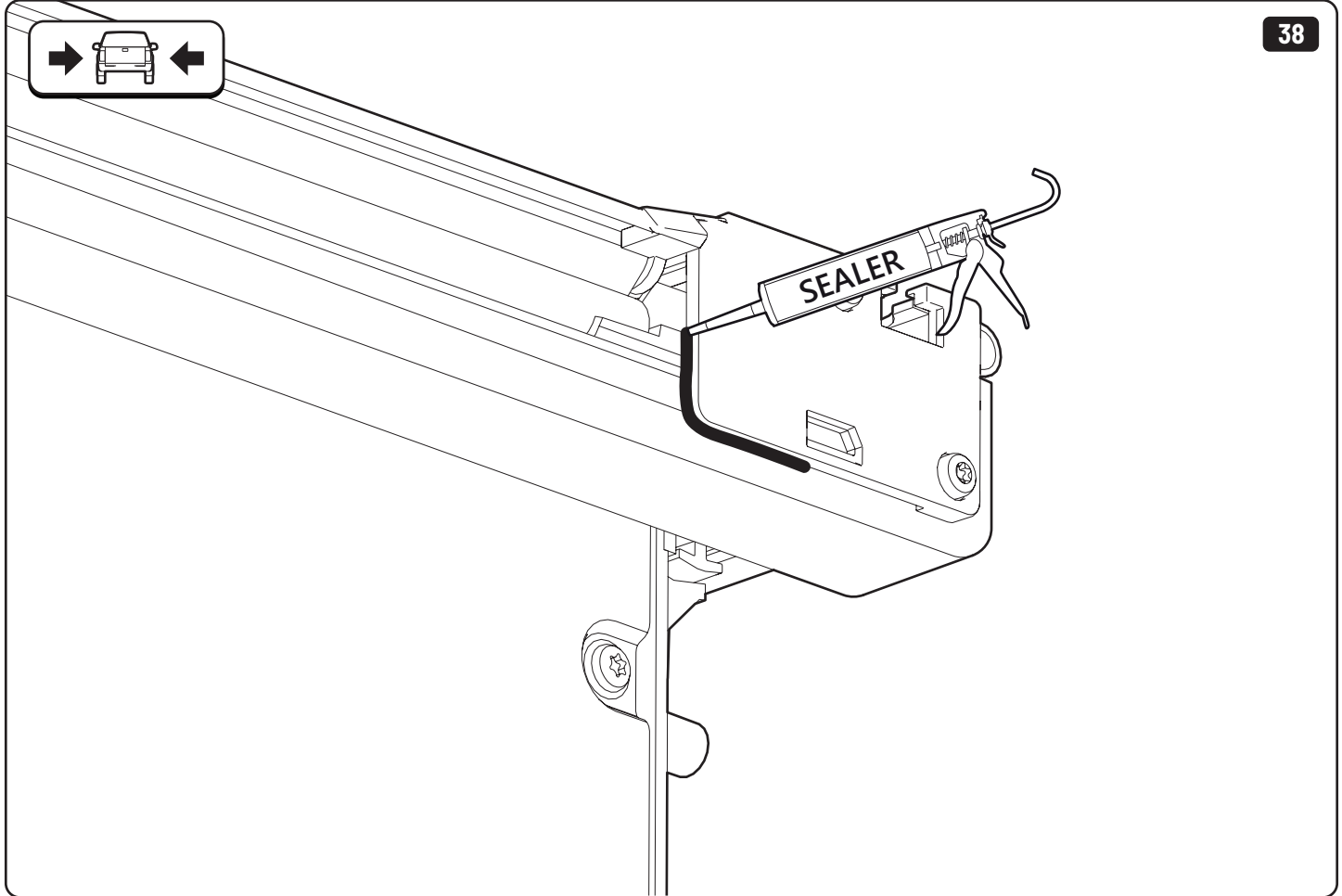

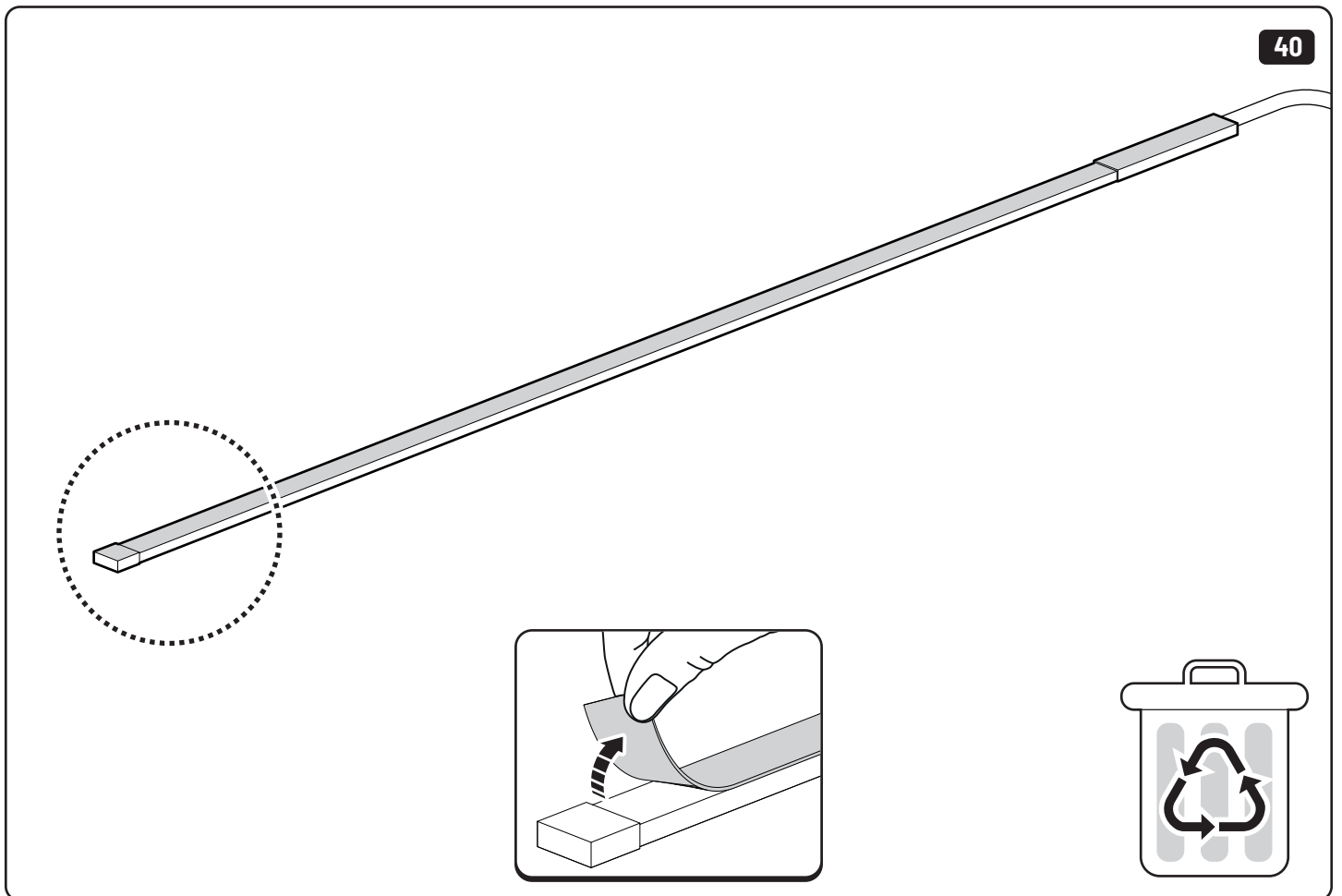
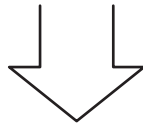
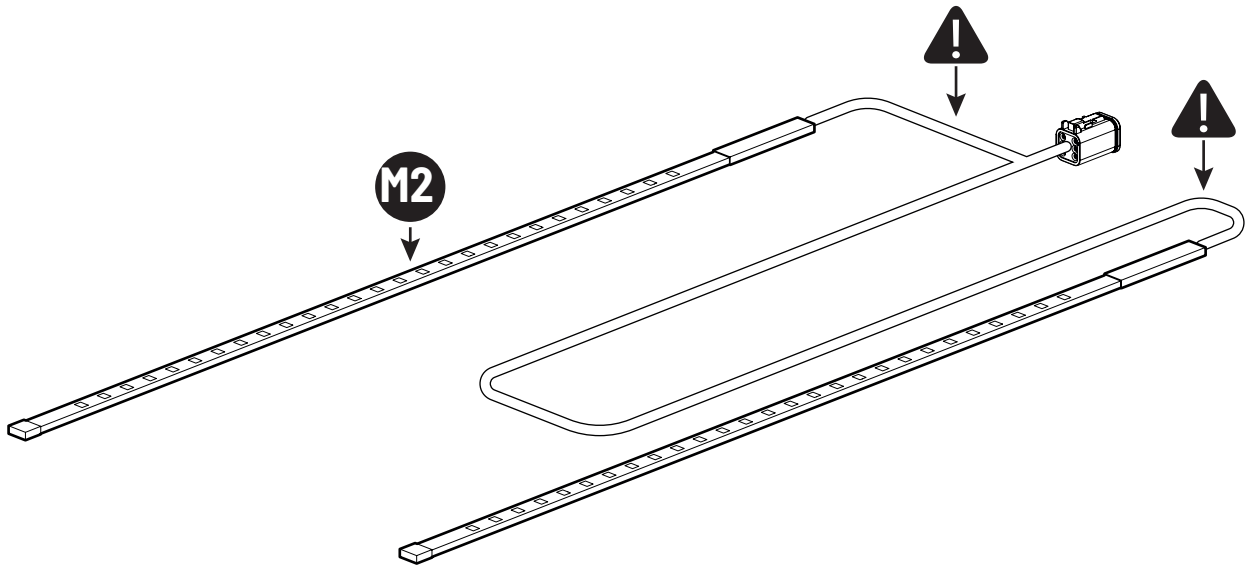

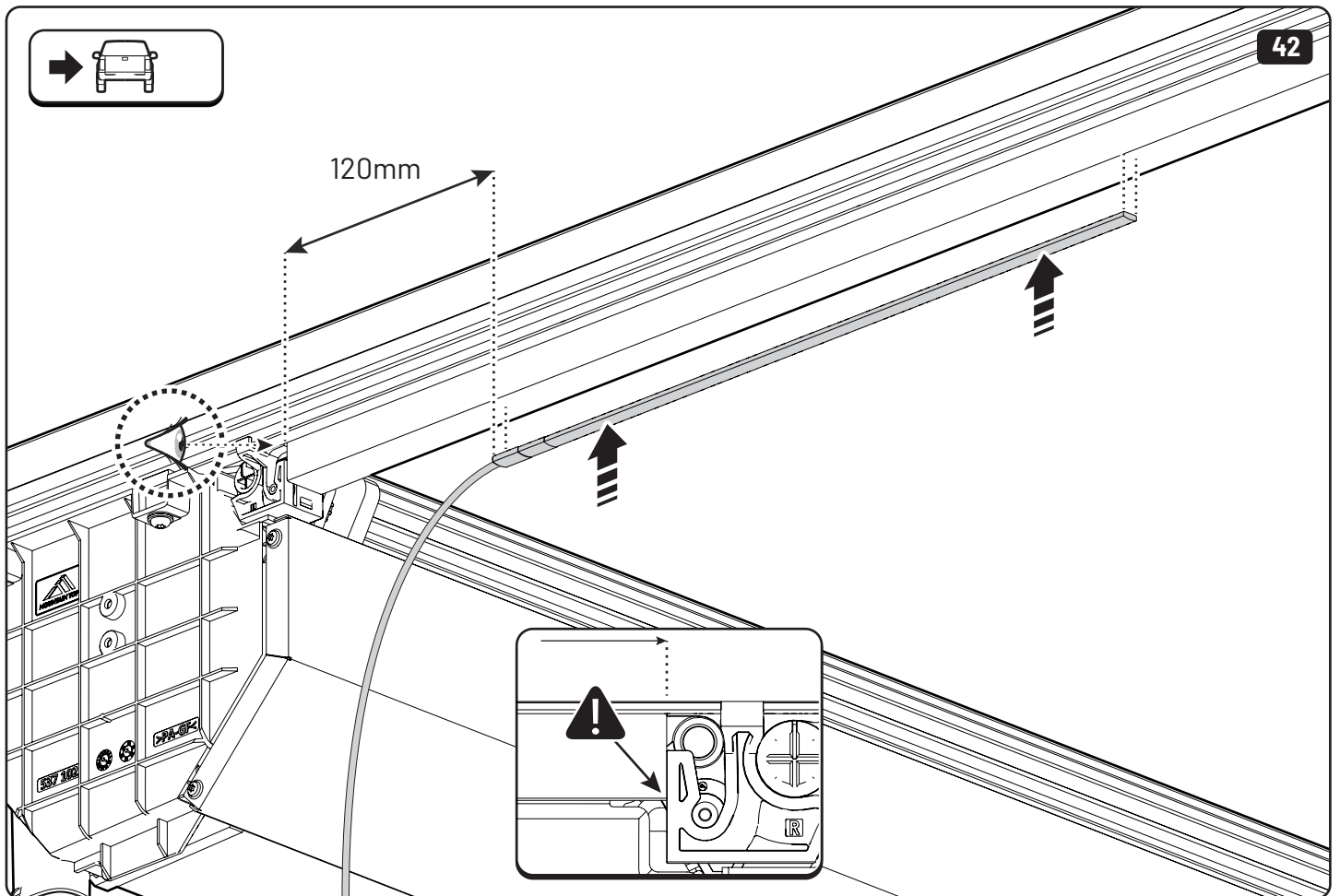
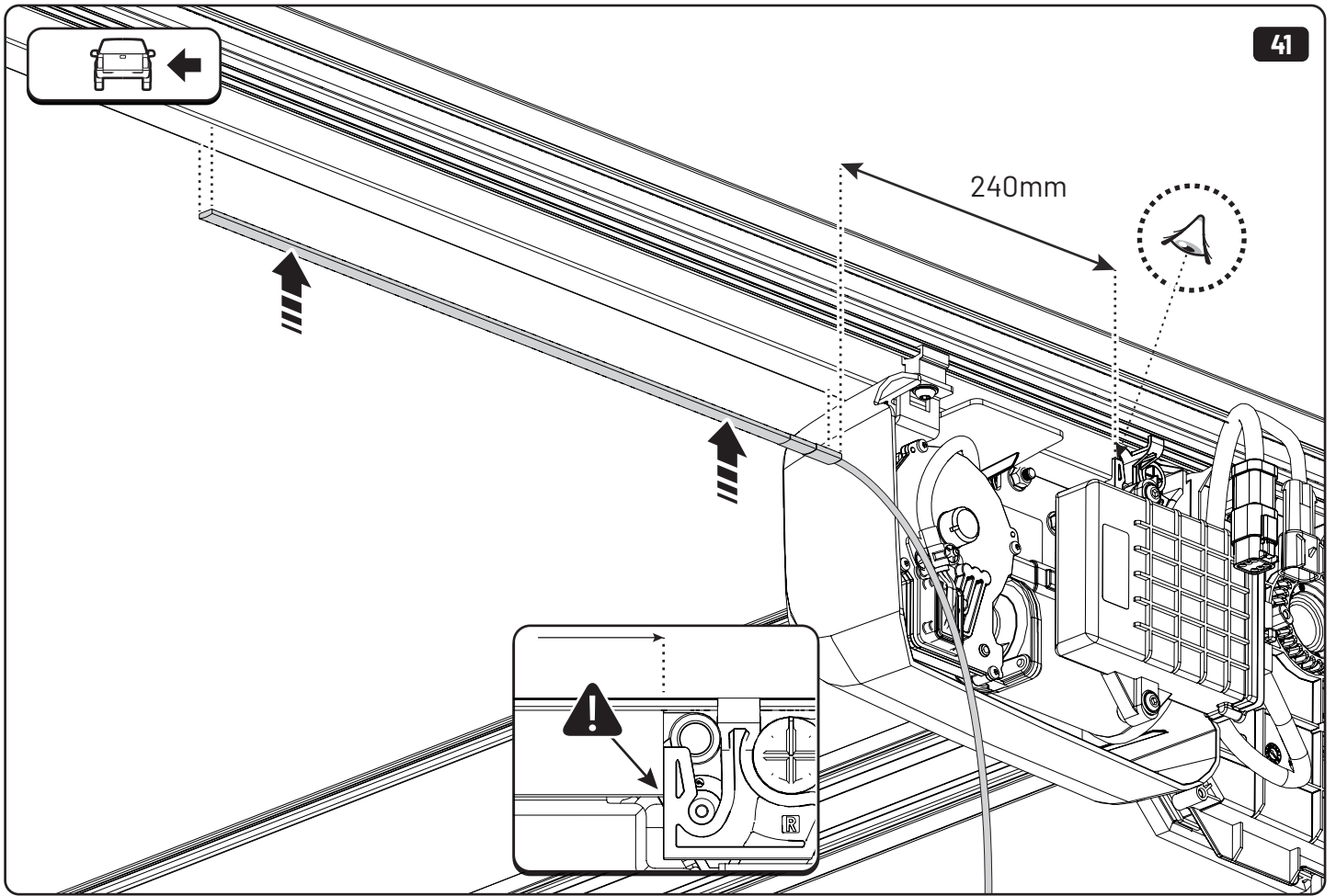

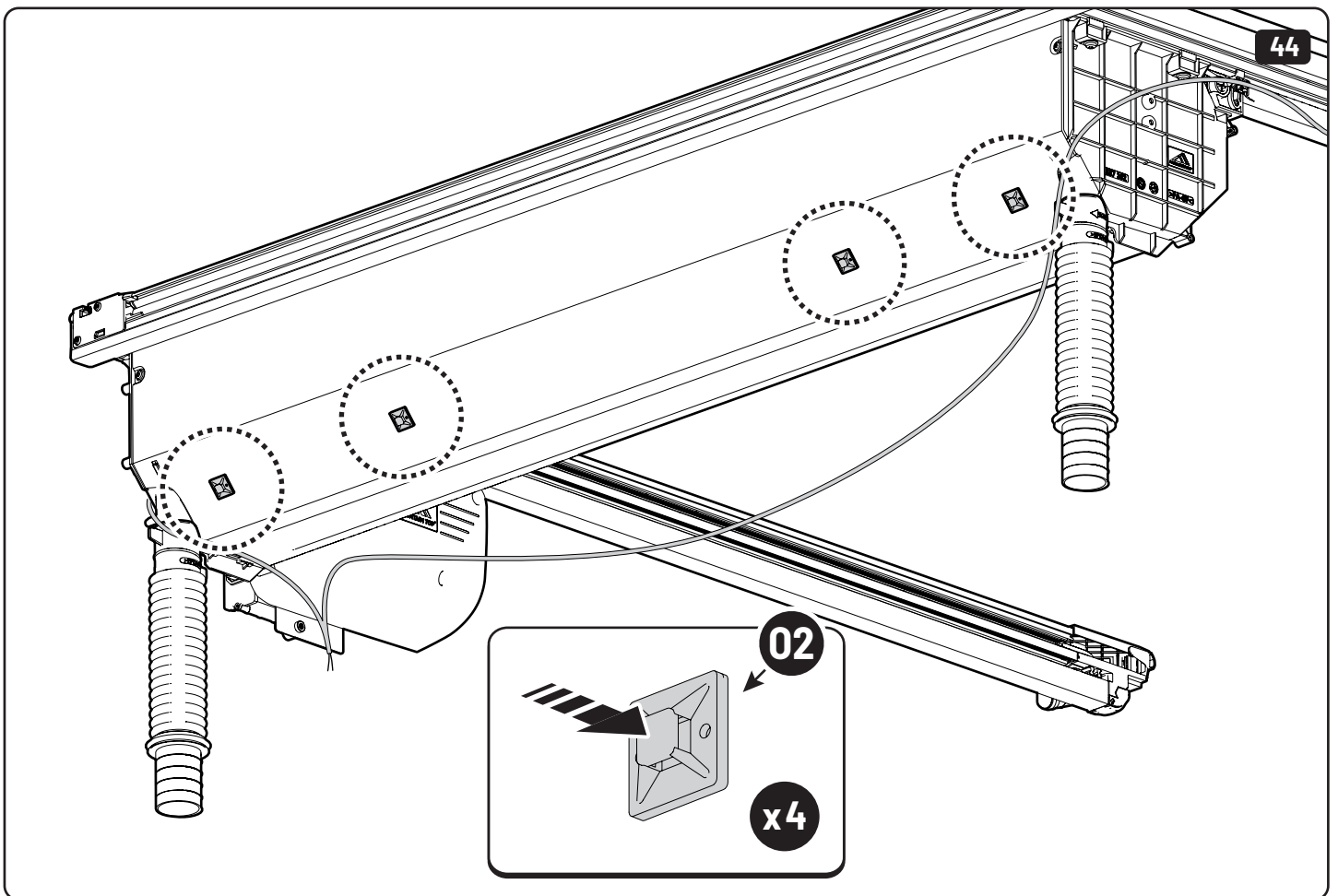
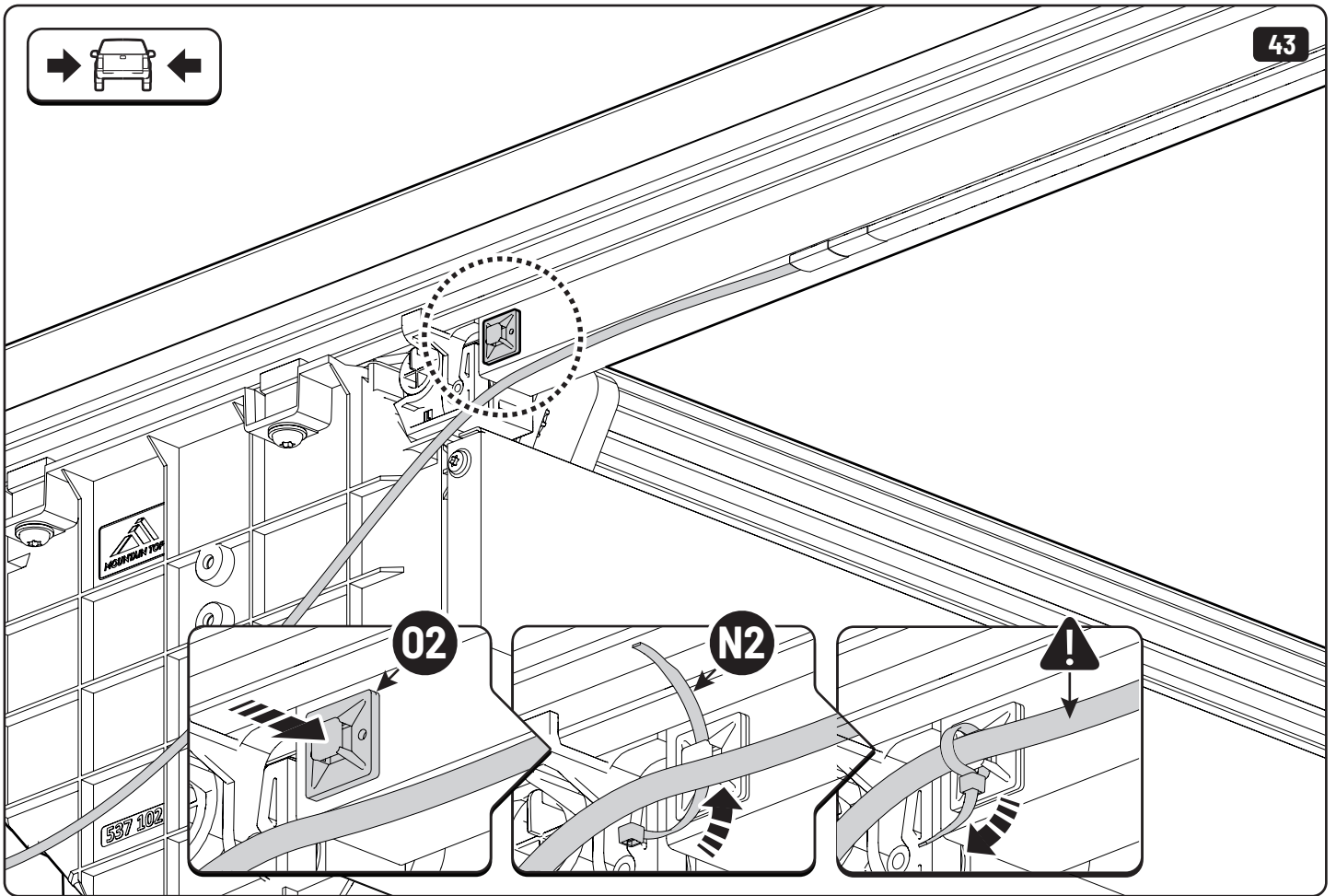

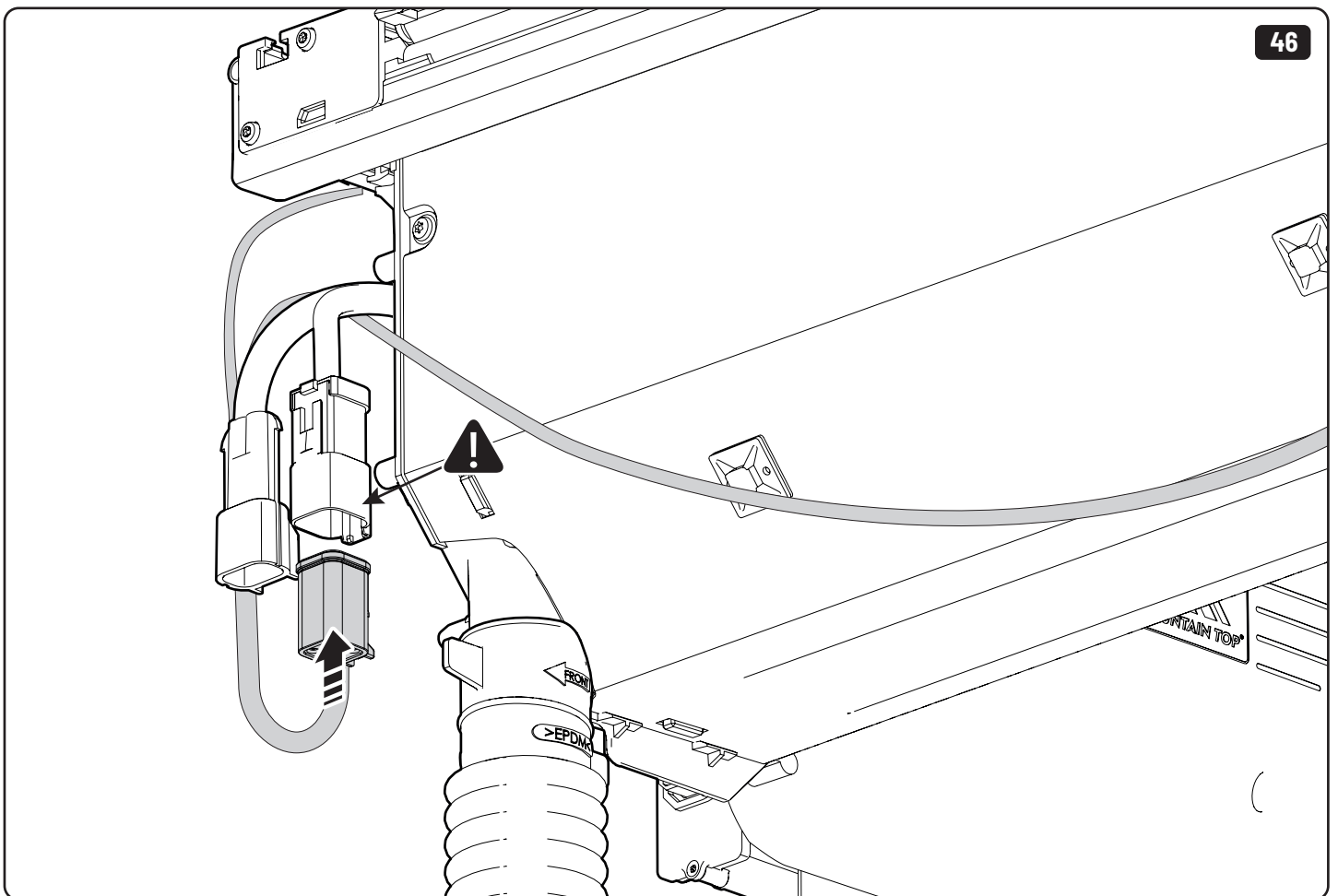
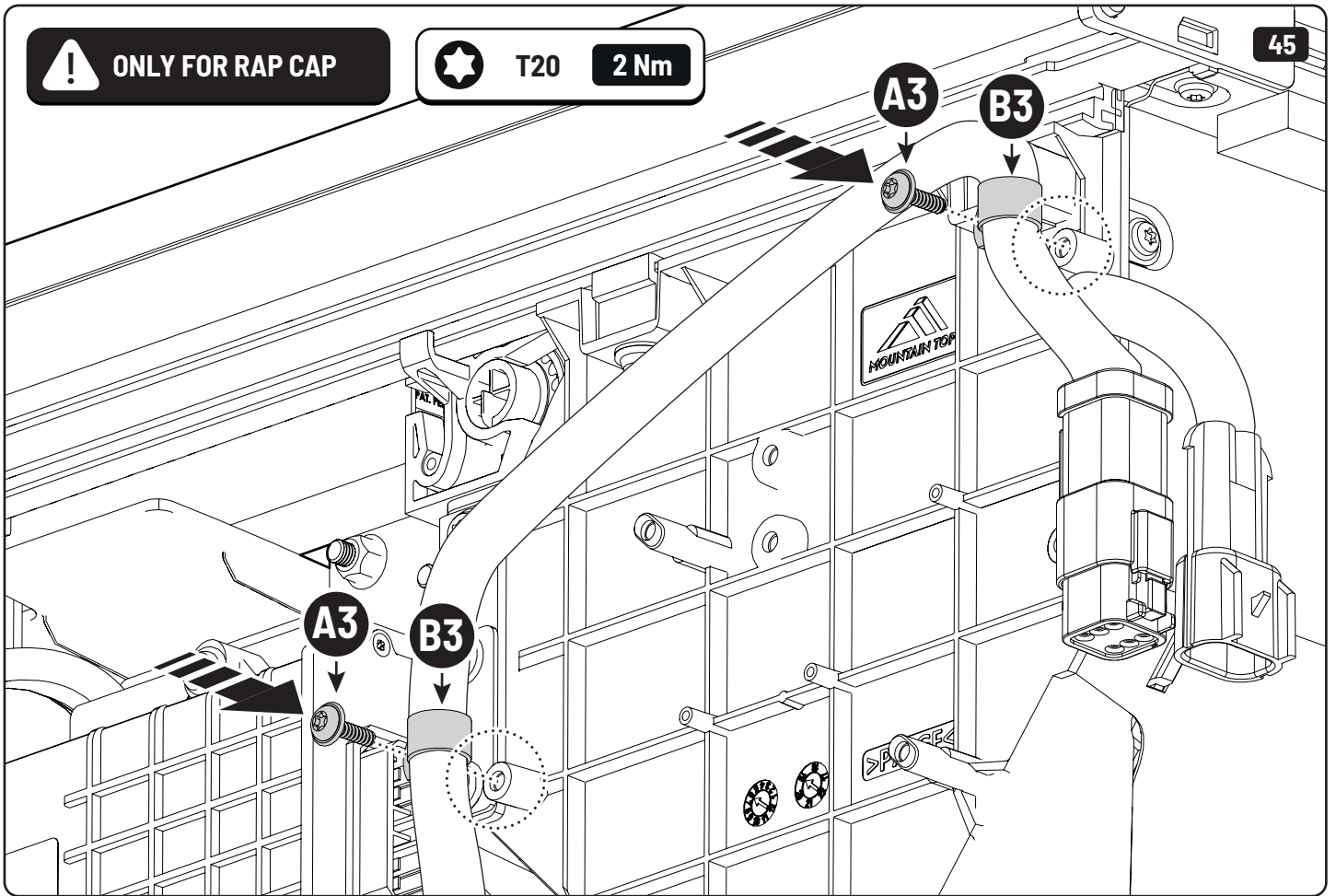

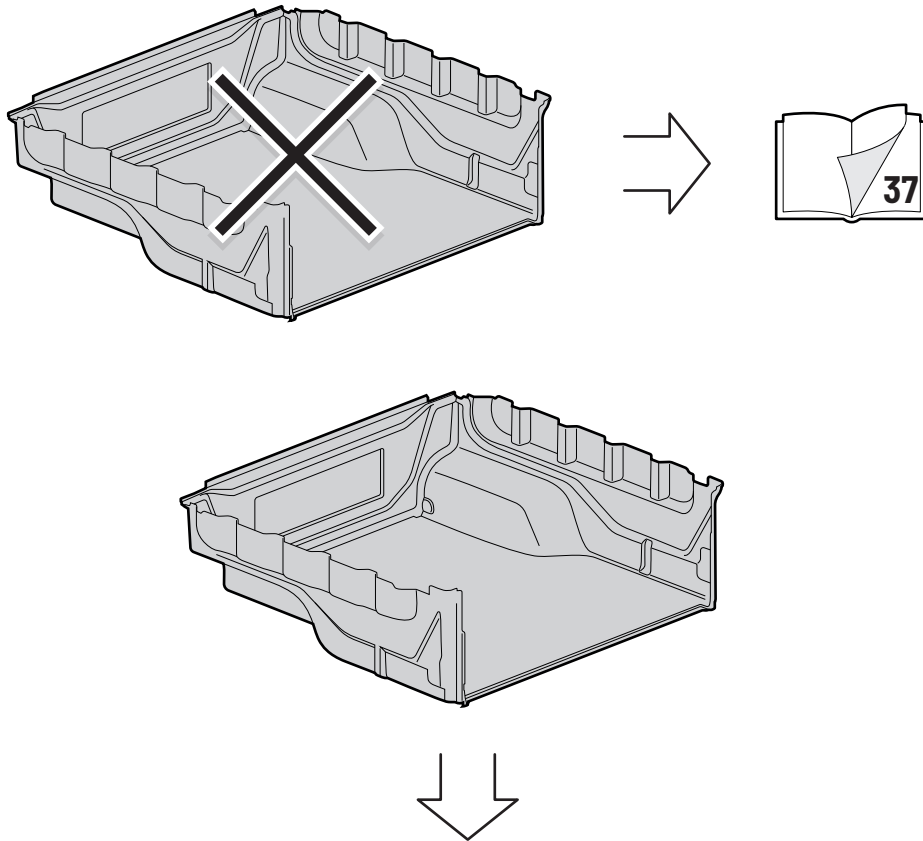

! ONLY WITH LINER

47

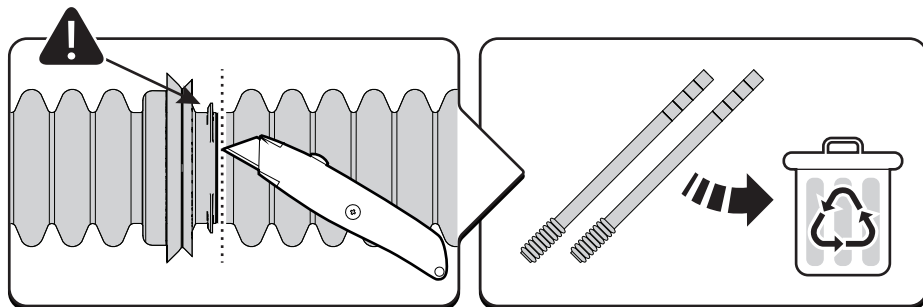
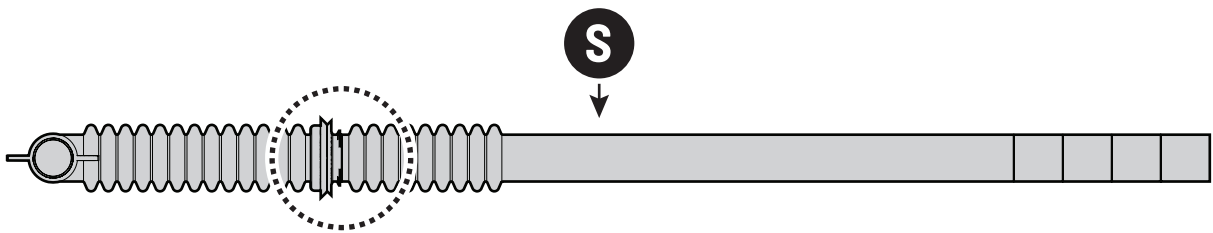

! ONLY WITH LINER

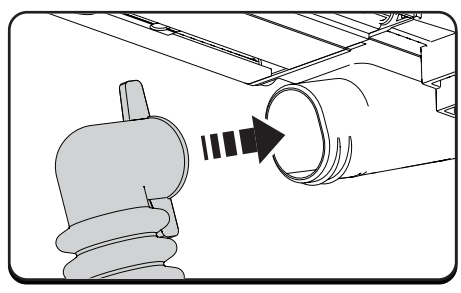
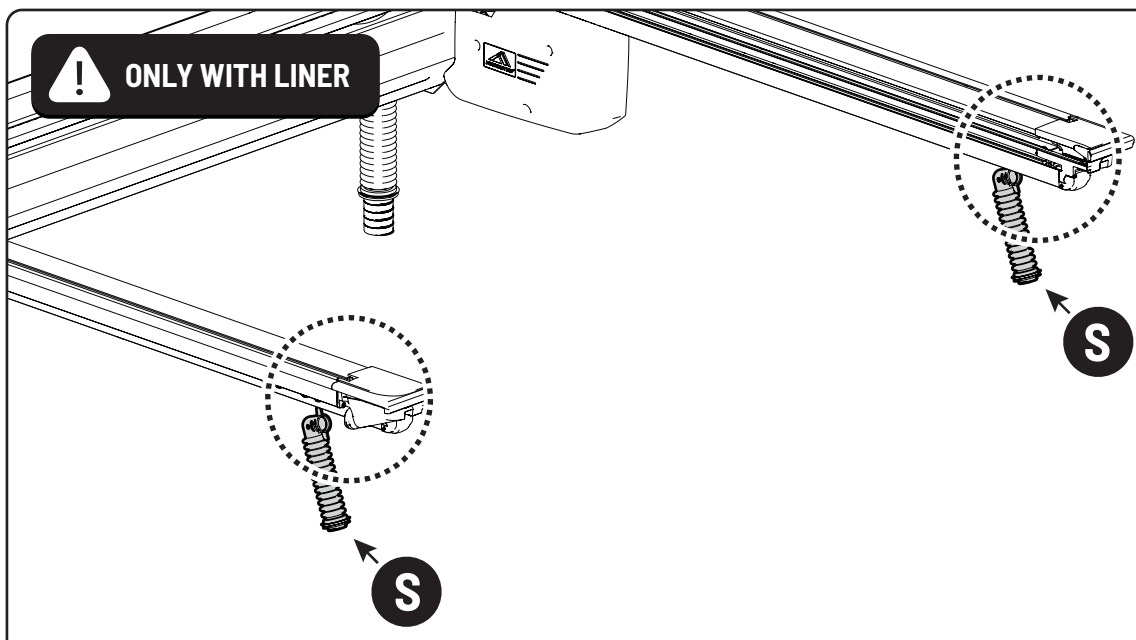

! ONLY WITH LINER

! EUROPEAN MODEL

X: 650 mm Y: 290 mm

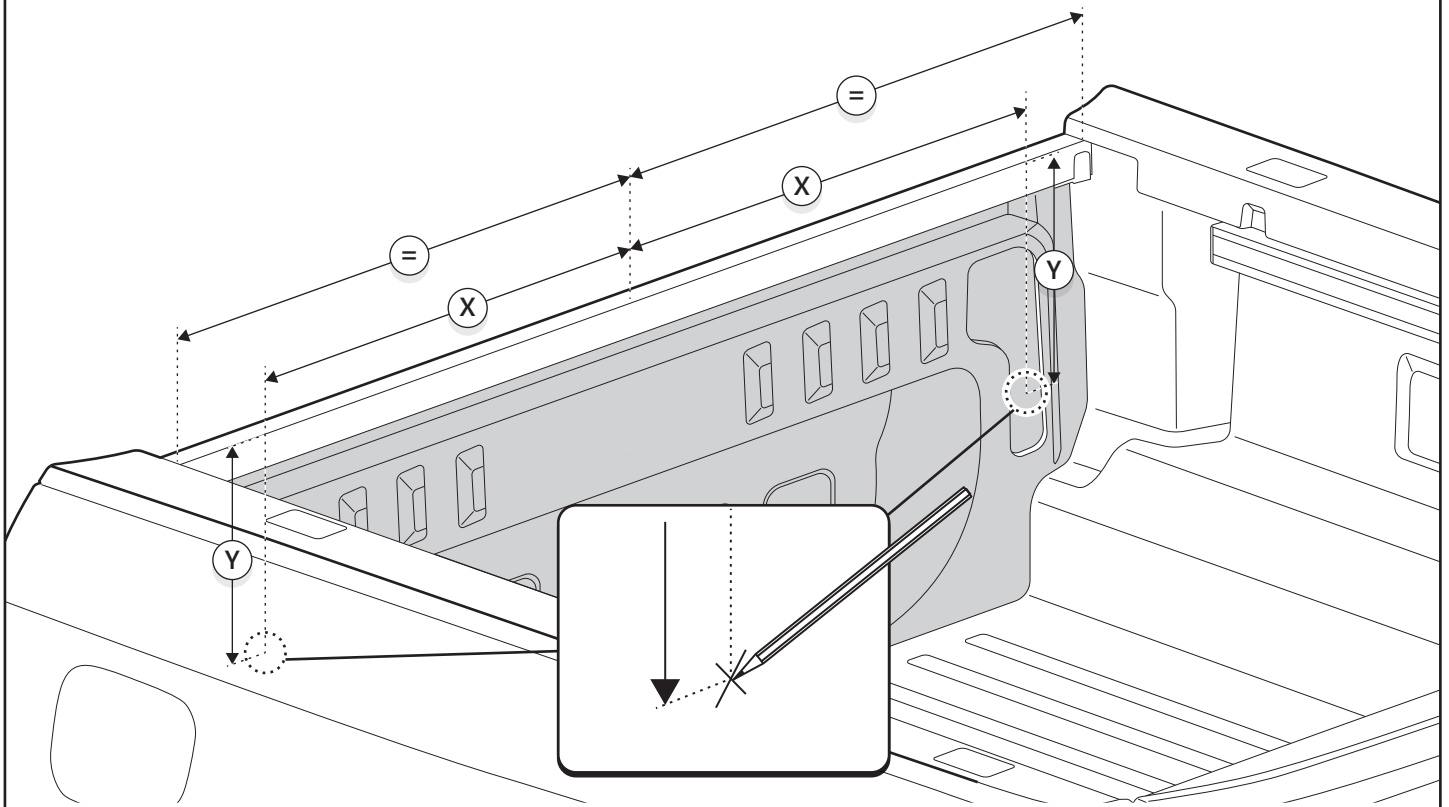

! ONLY WITH LINER

! OTHER MODELS

X: 560 mm Y: 330 mm

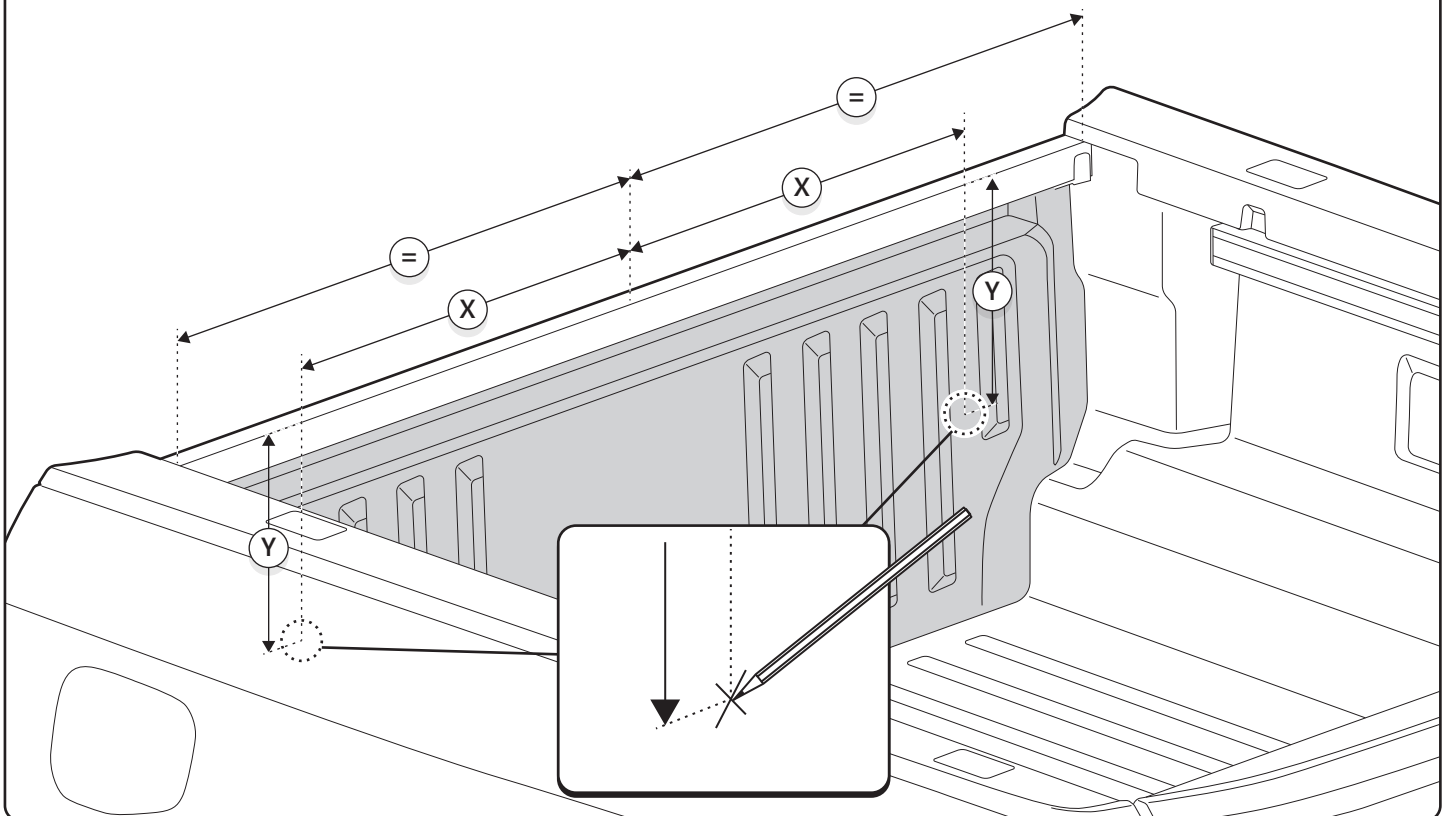

! ONLY WITH LINER

 Ø 3,5mm

 Ø40 mm

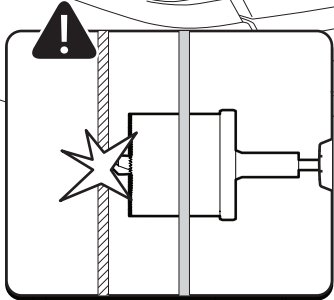
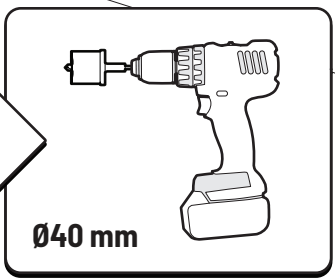
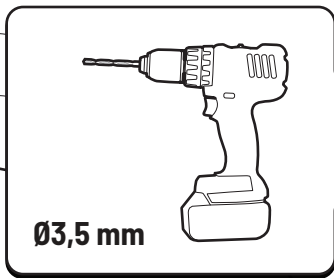
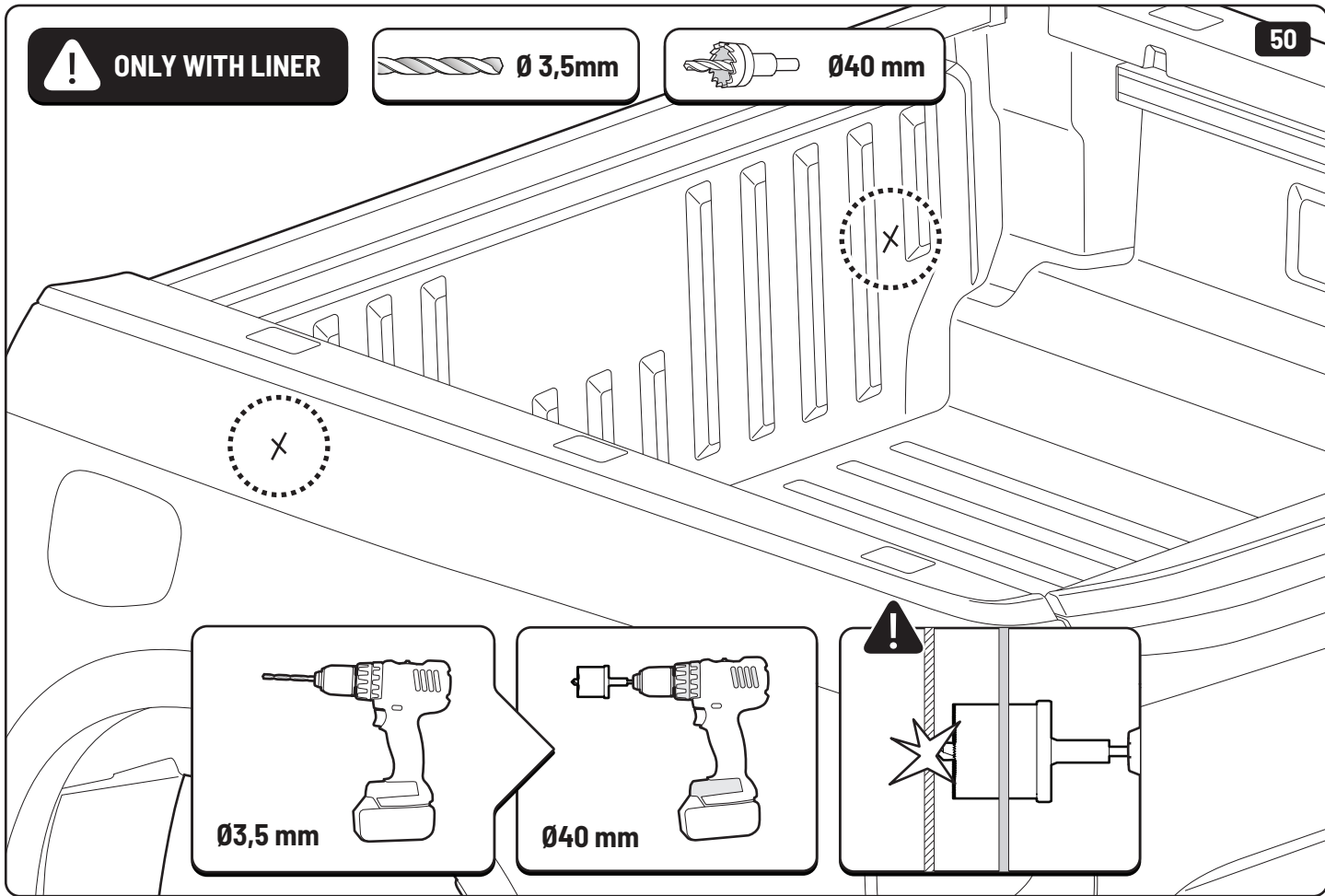

! ONLY WITH LINER

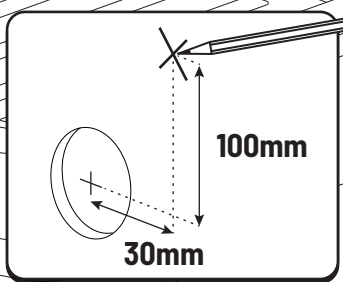
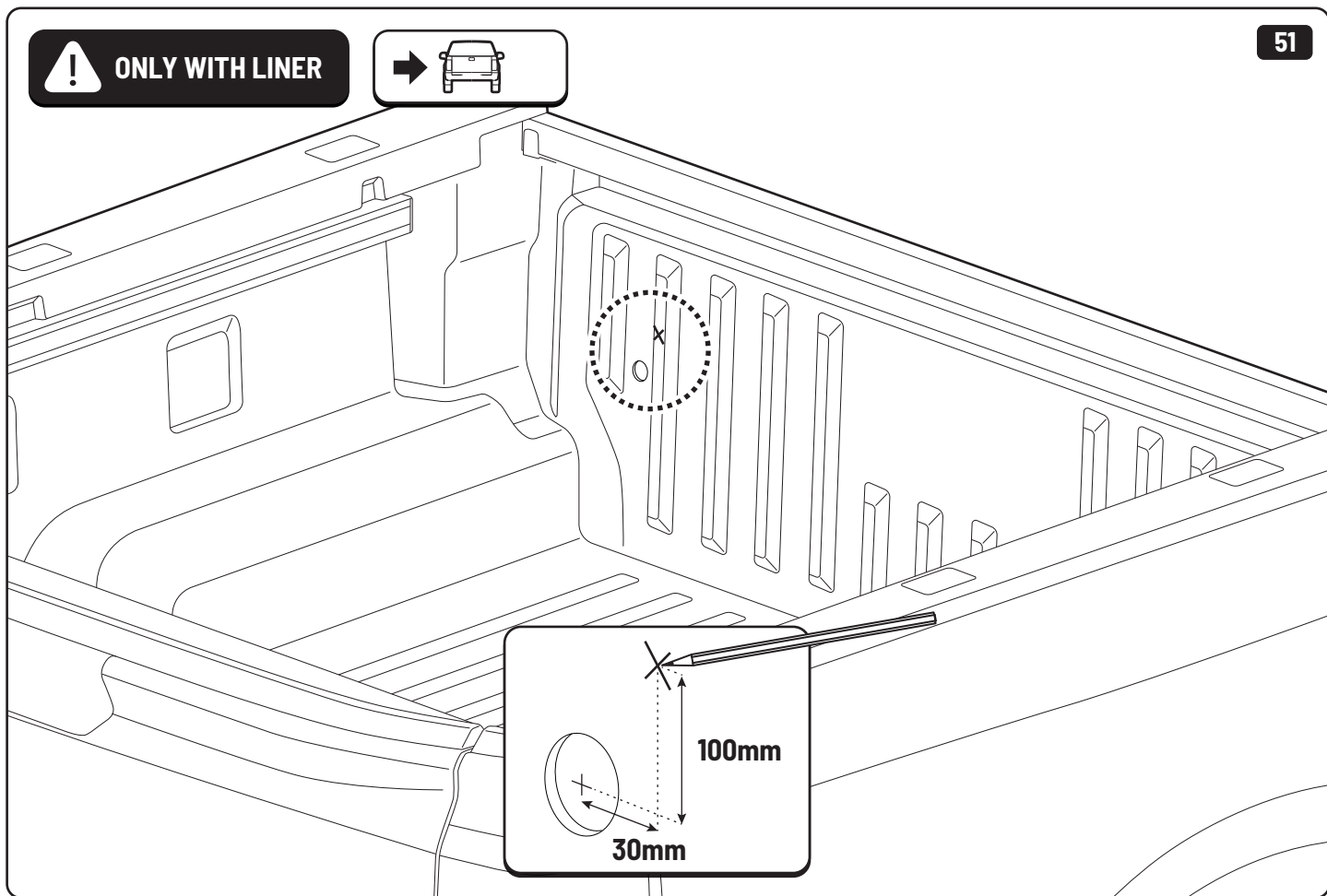

! ONLY WITH LINER



52

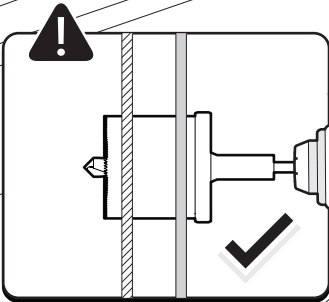
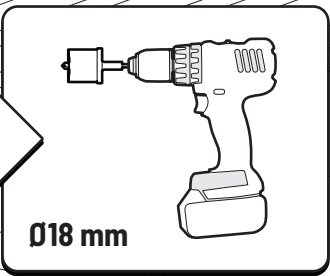
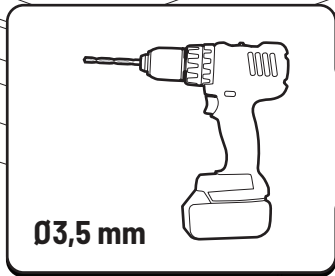
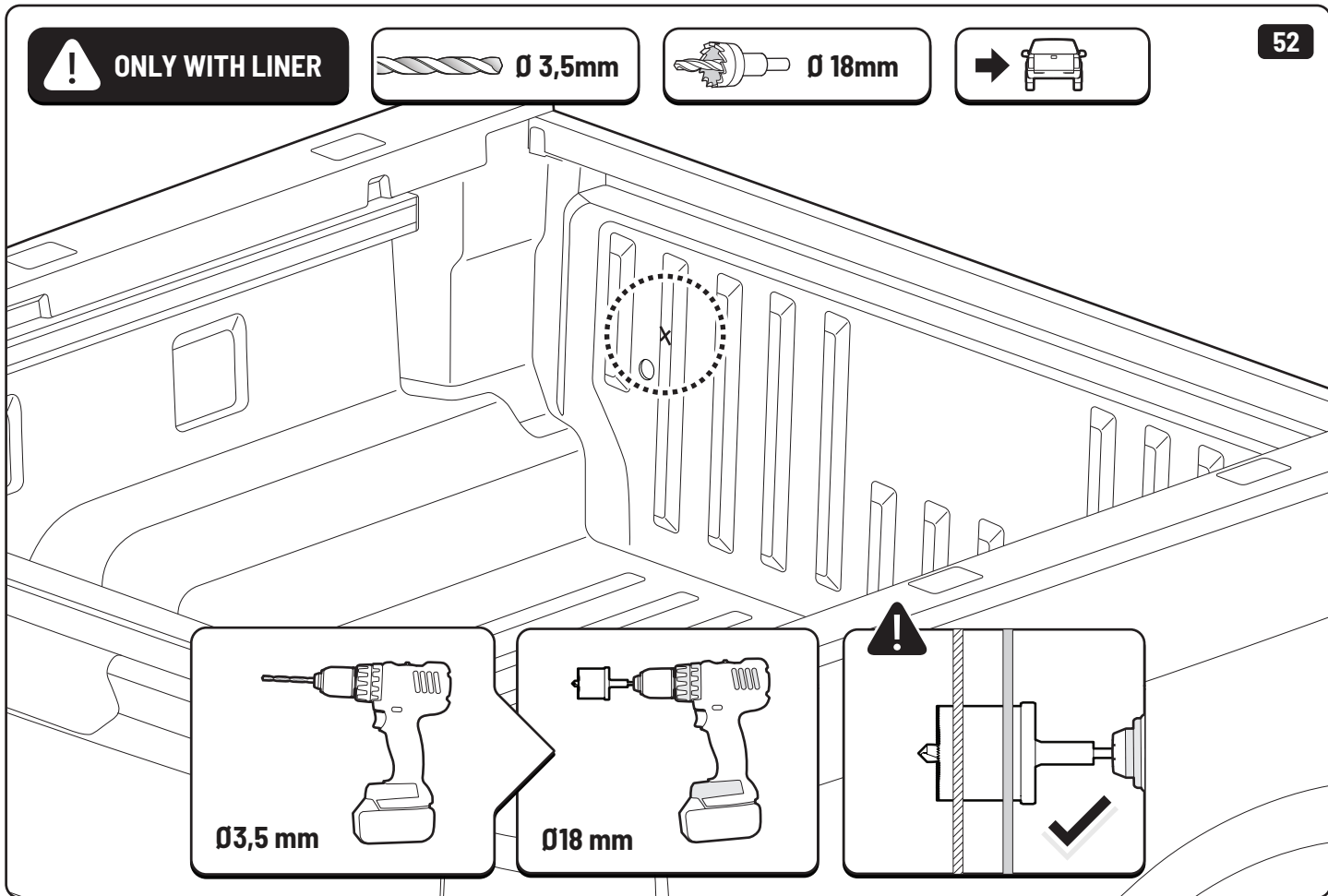

! ONLY WITH LINER



53

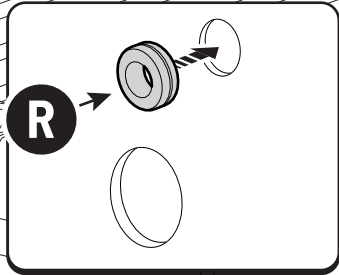
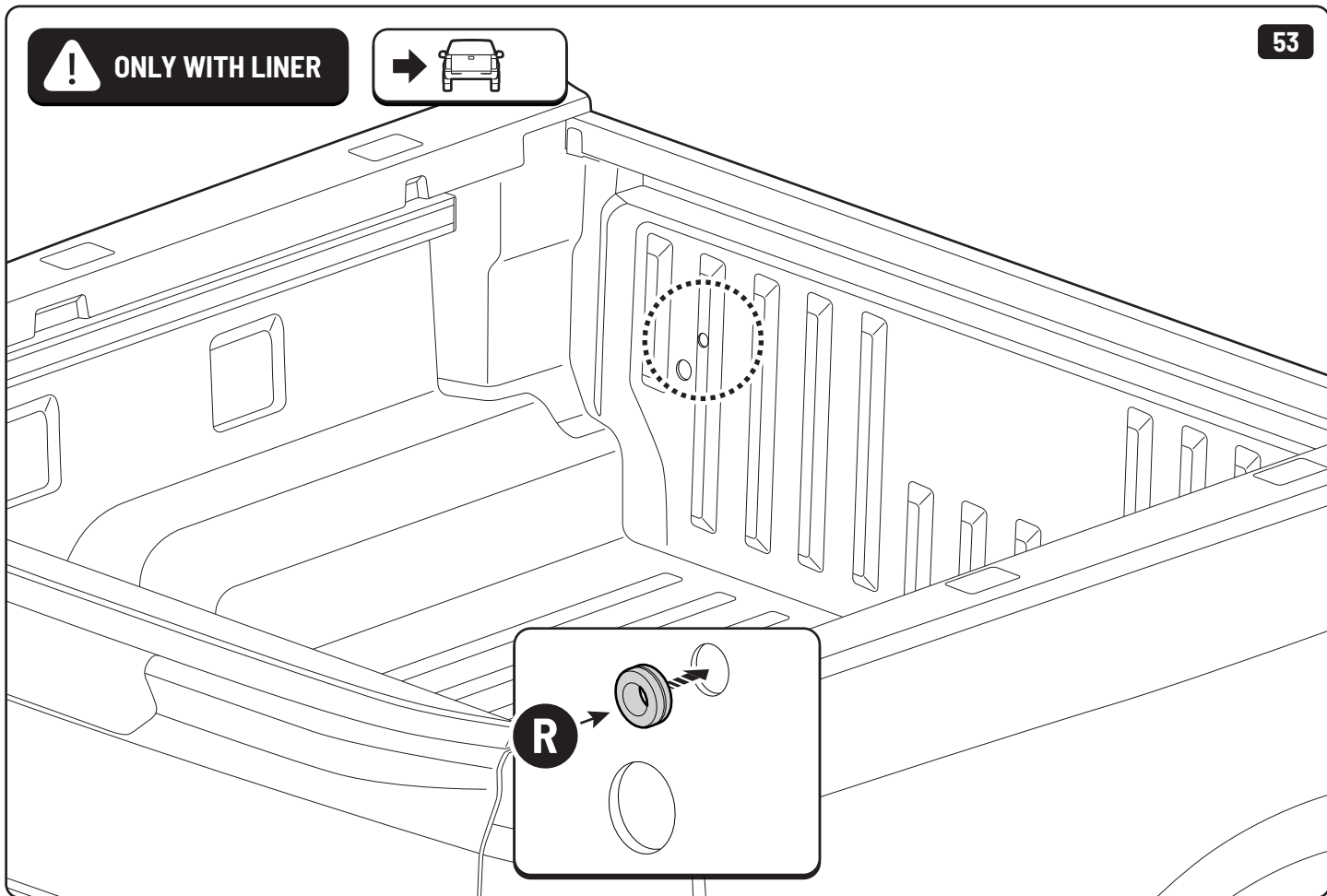

! ONLY WITH LINER

A: 30 mm B: 20 mm

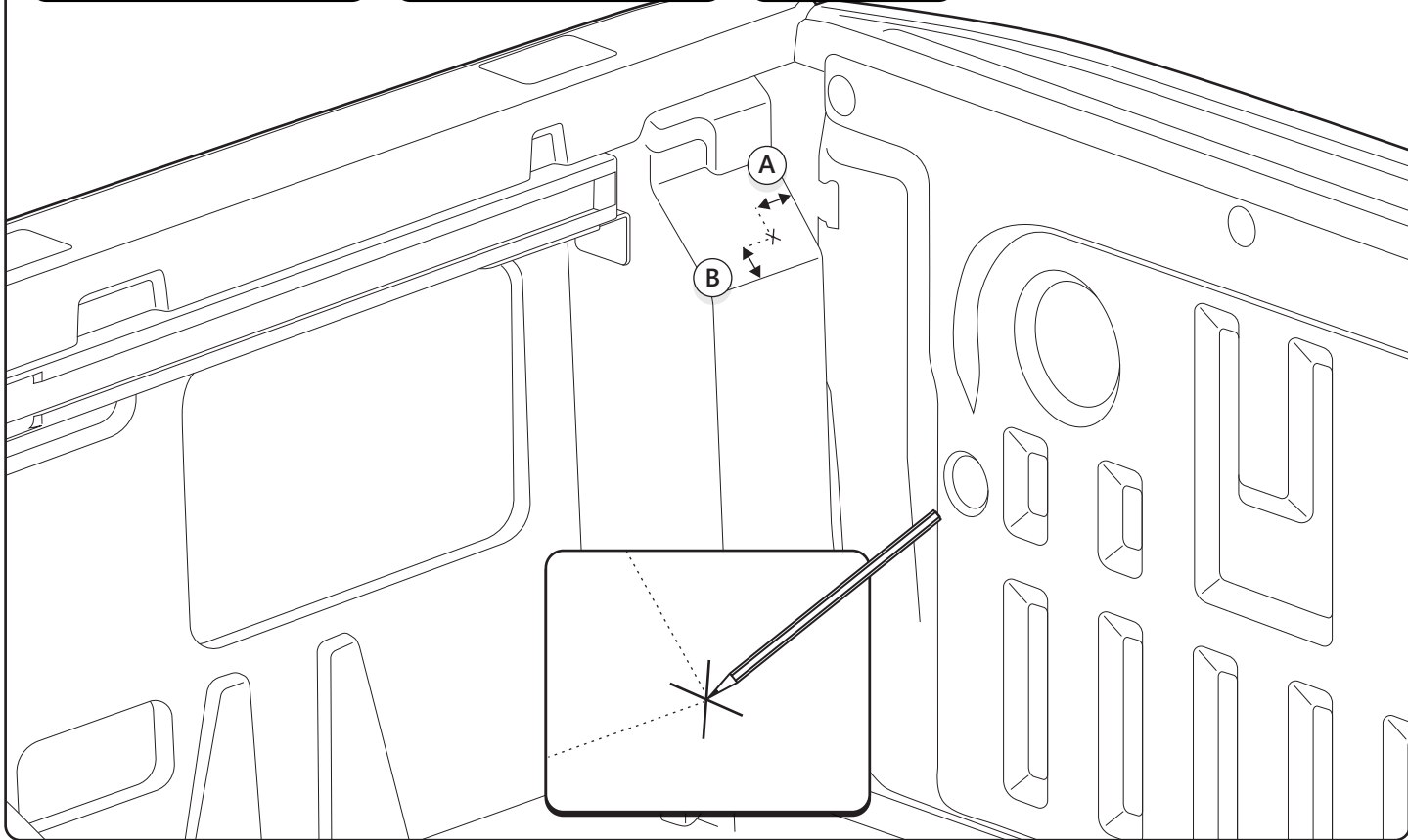

! ONLY WITH LINER

Ø 3,5mm

Ø30 mm

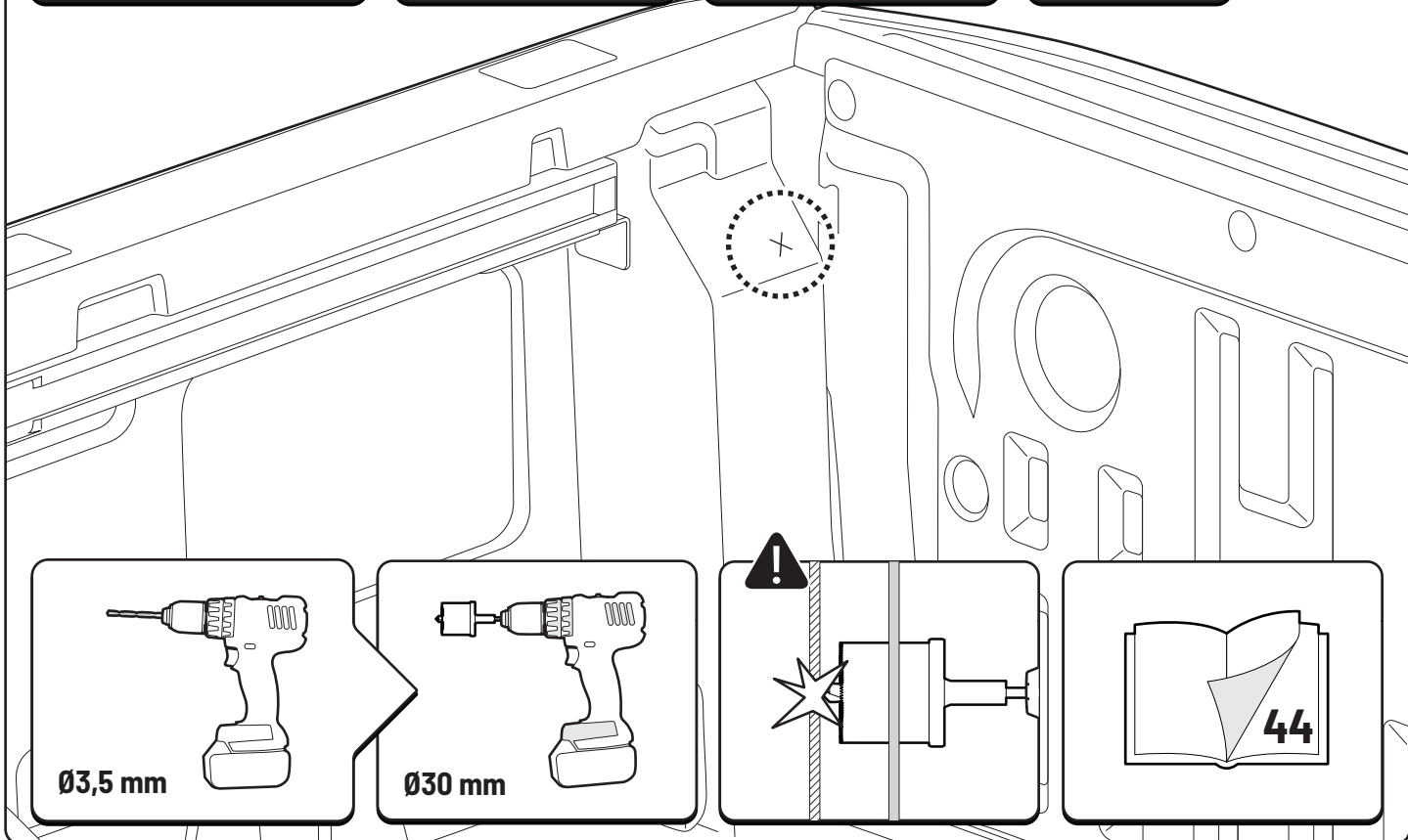
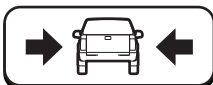

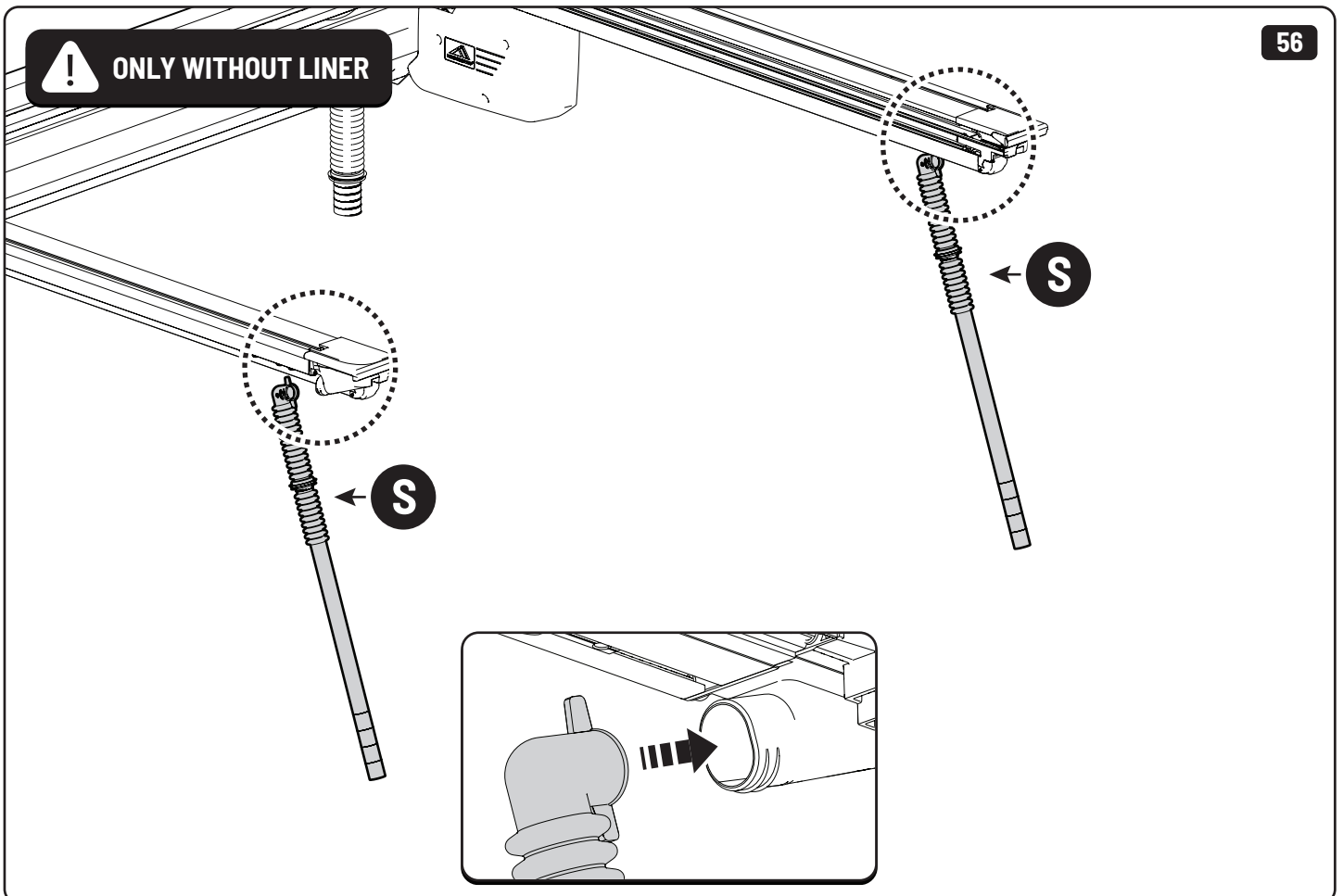
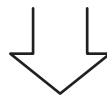
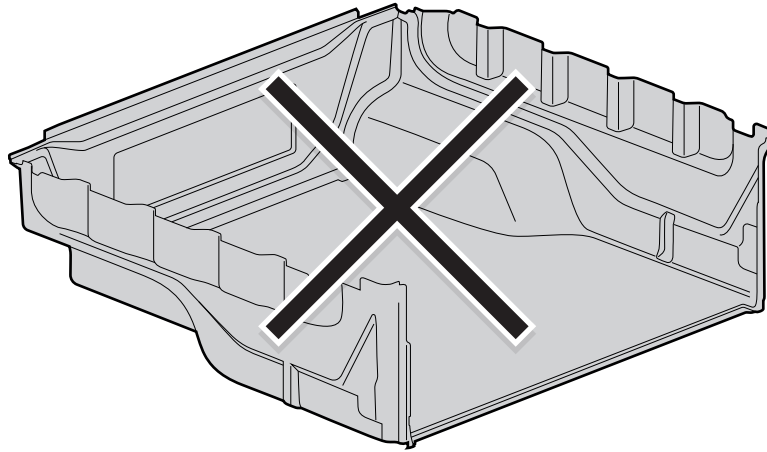

! ONLY WITHOUT LINER

! EUROPEAN MODEL

Double Cab: X = 650mm Y = 290 mm
Rap Cab: X = 650mm Y = 320 mm

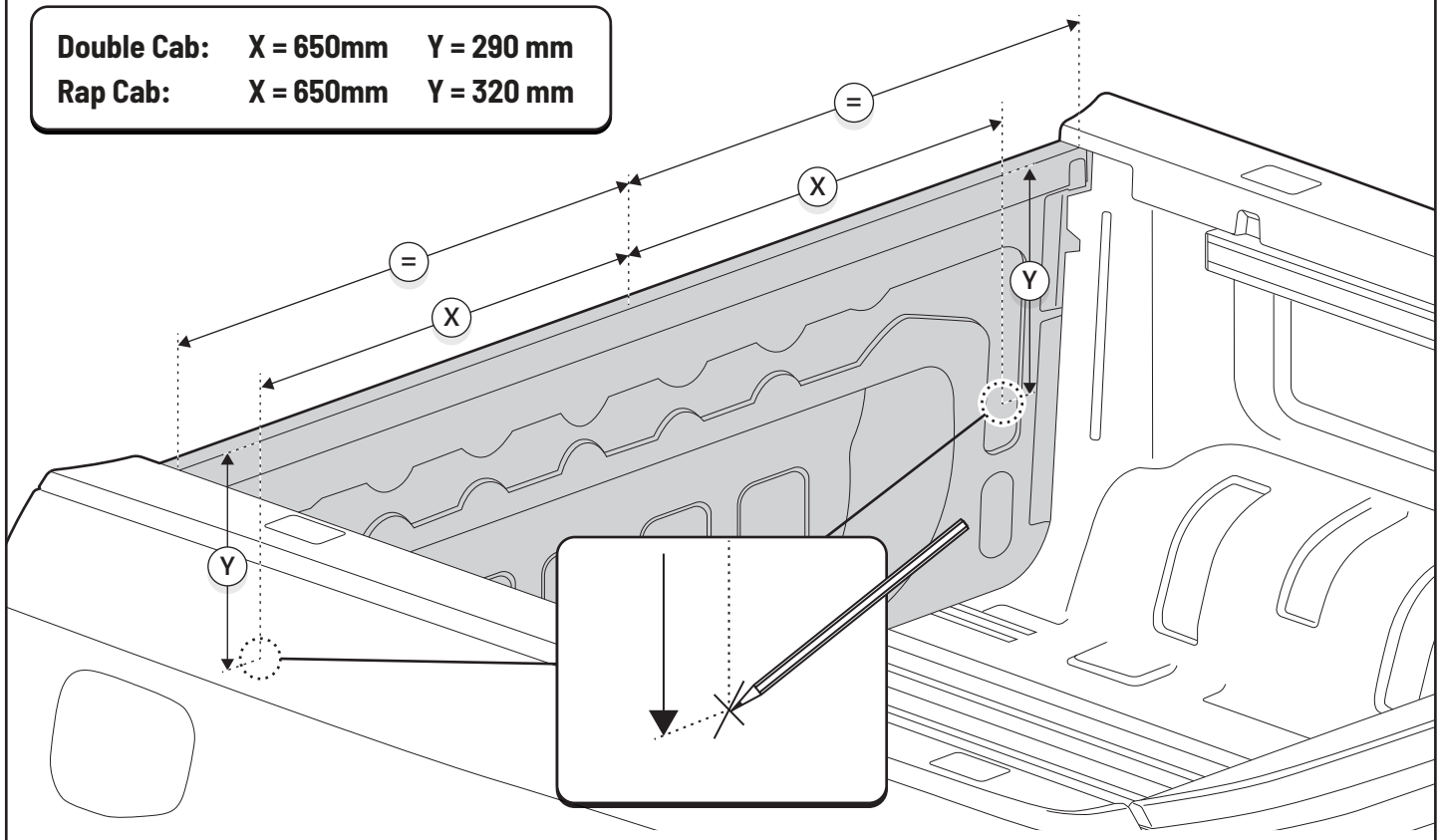

! ONLY WITHOUT LINER

! OTHER MODELS

Double Cab: X = 580 mm Y = 290 mm
Rap Cab: X = 580 mm Y = 320 mm

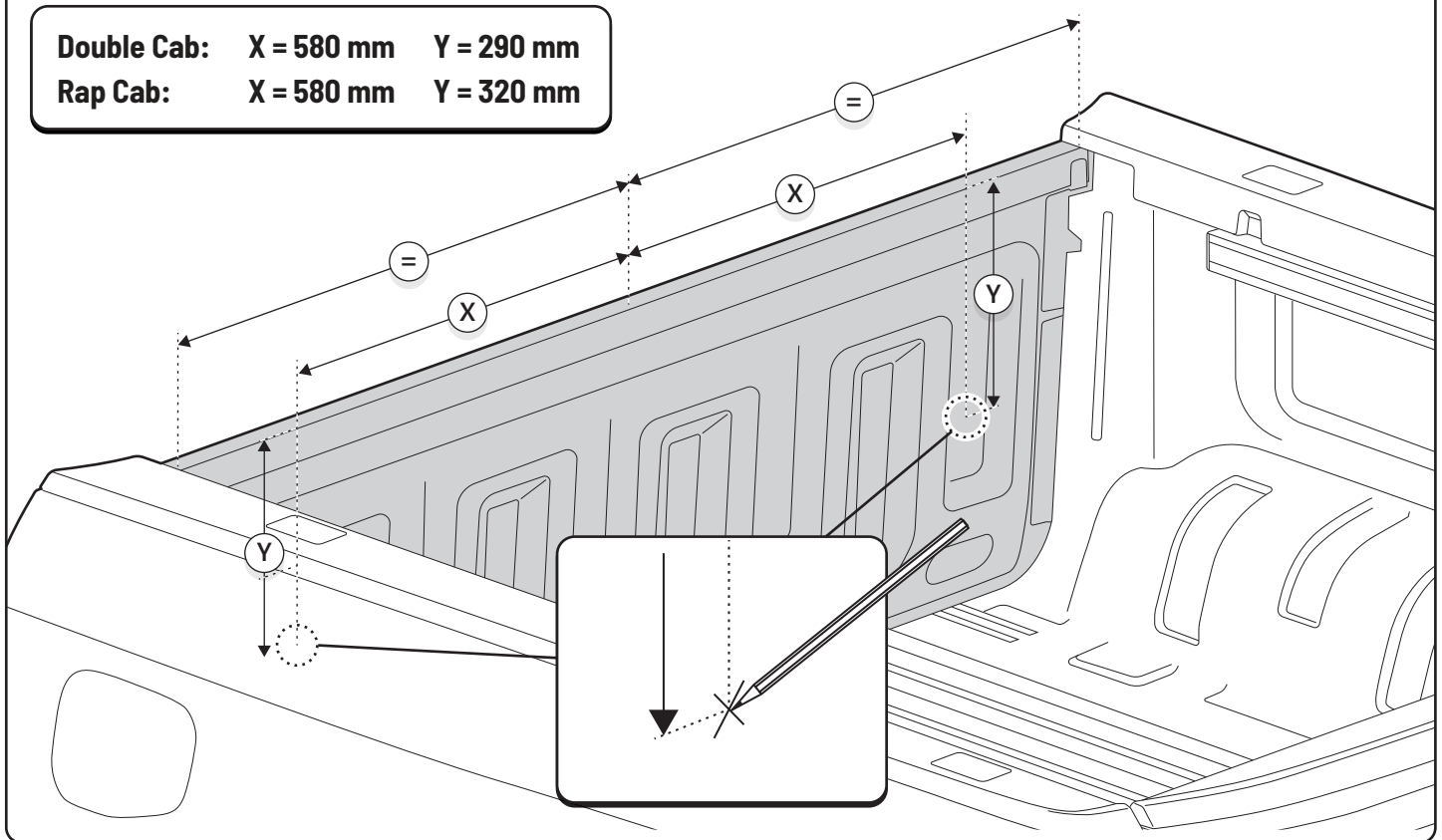

! ONLY WITHOUT LINER

 **Ø40 mm**

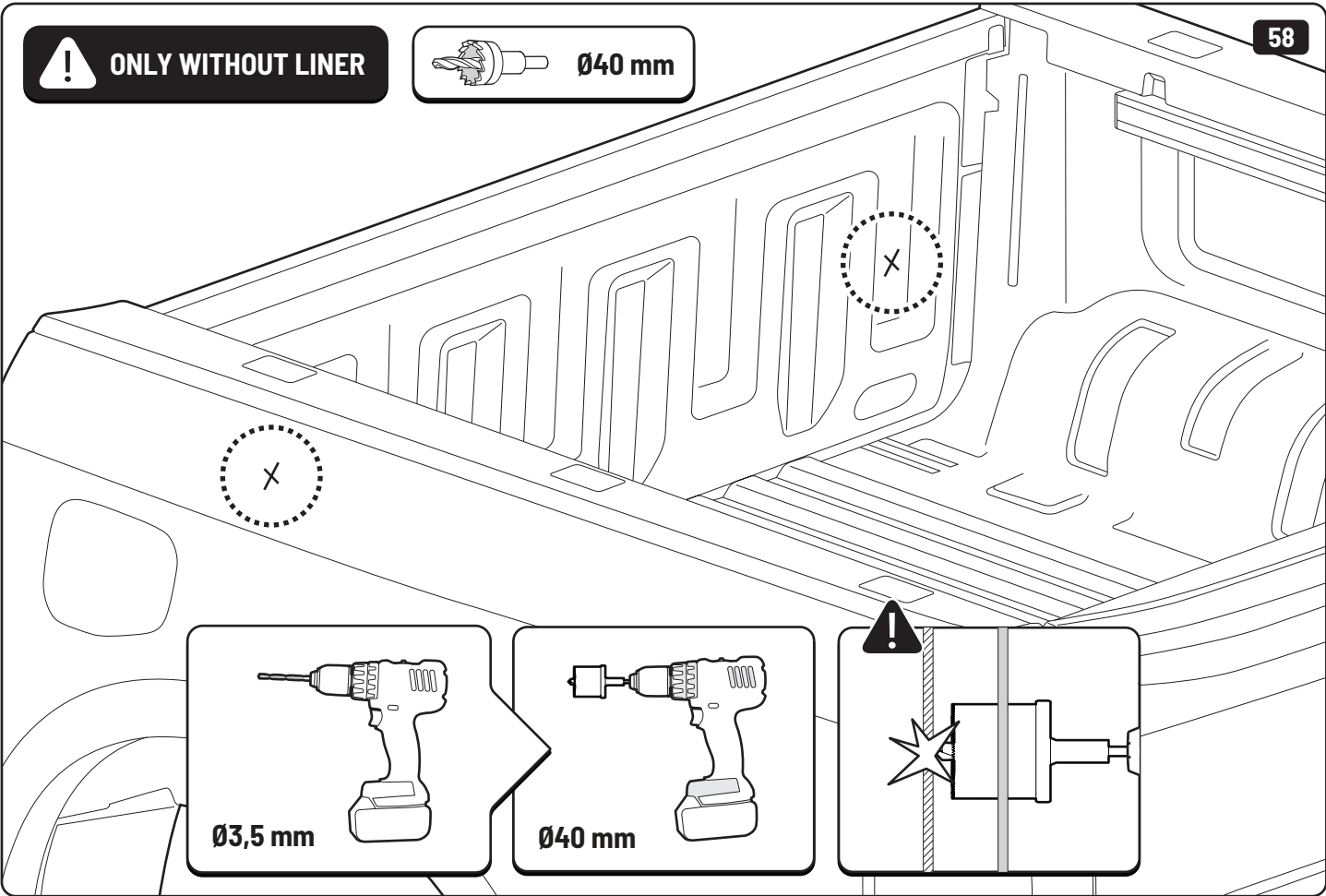

! ONLY WITHOUT LINER

! Rust Protection

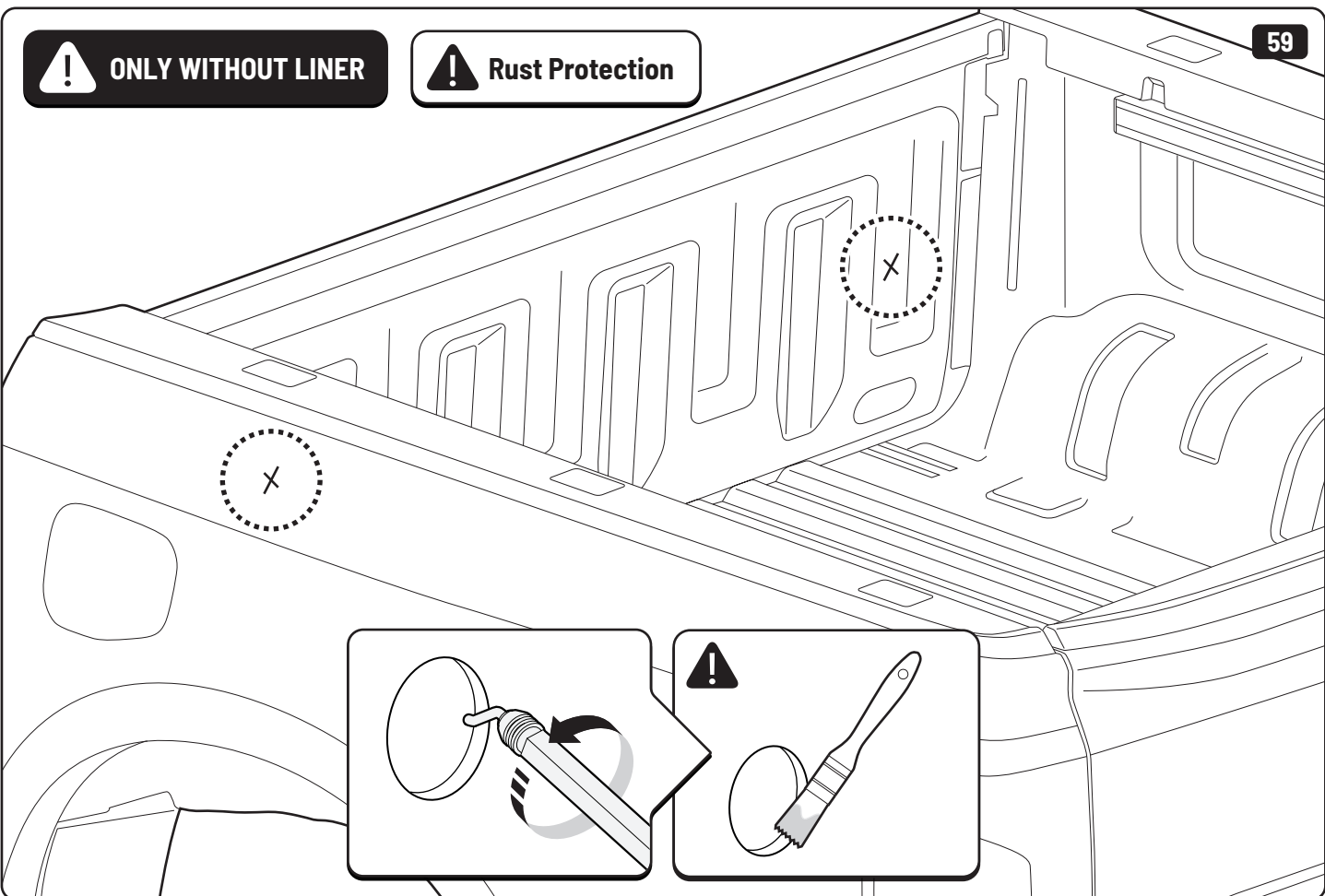

! ONLY WITHOUT LINER

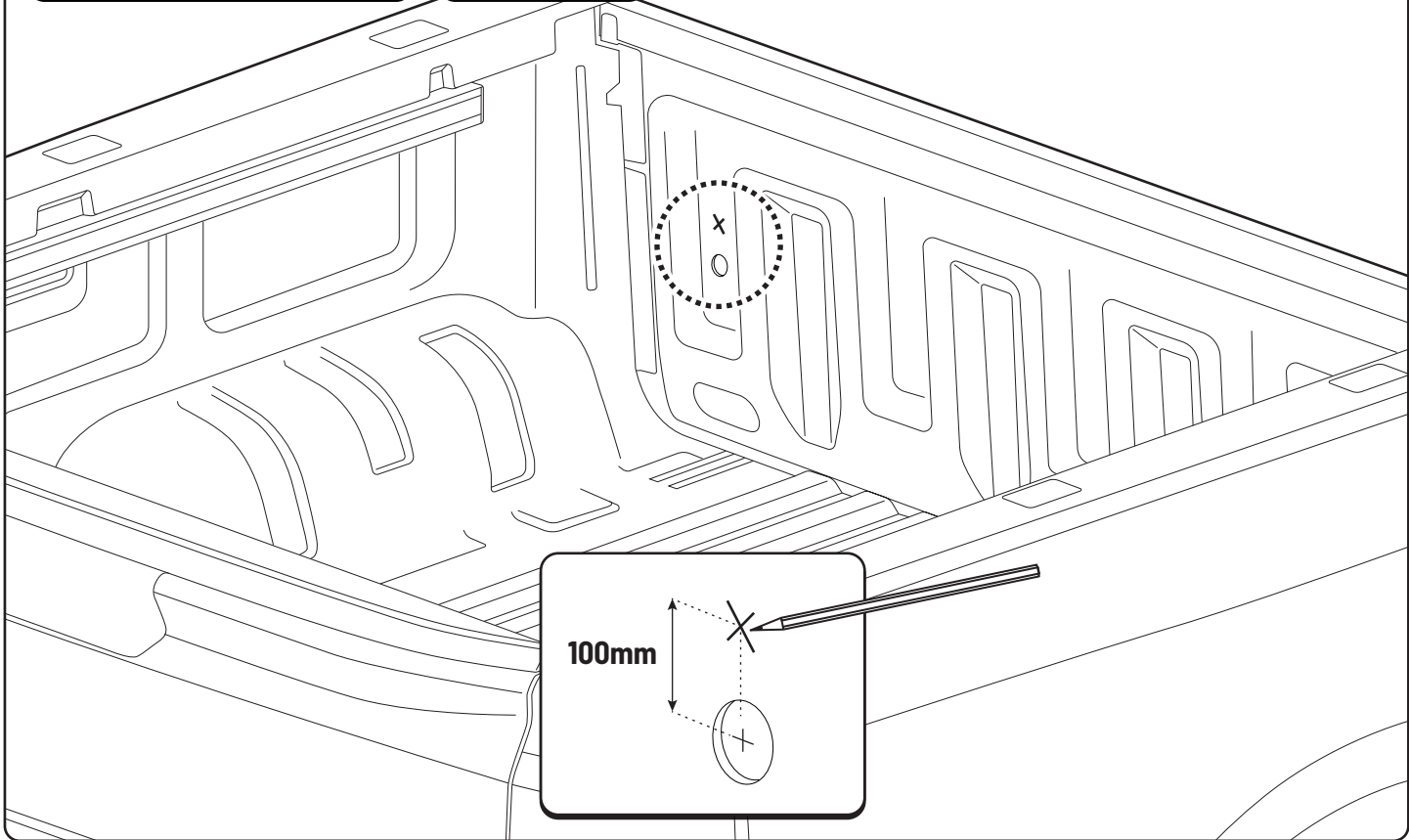

! ONLY WITHOUT LINER

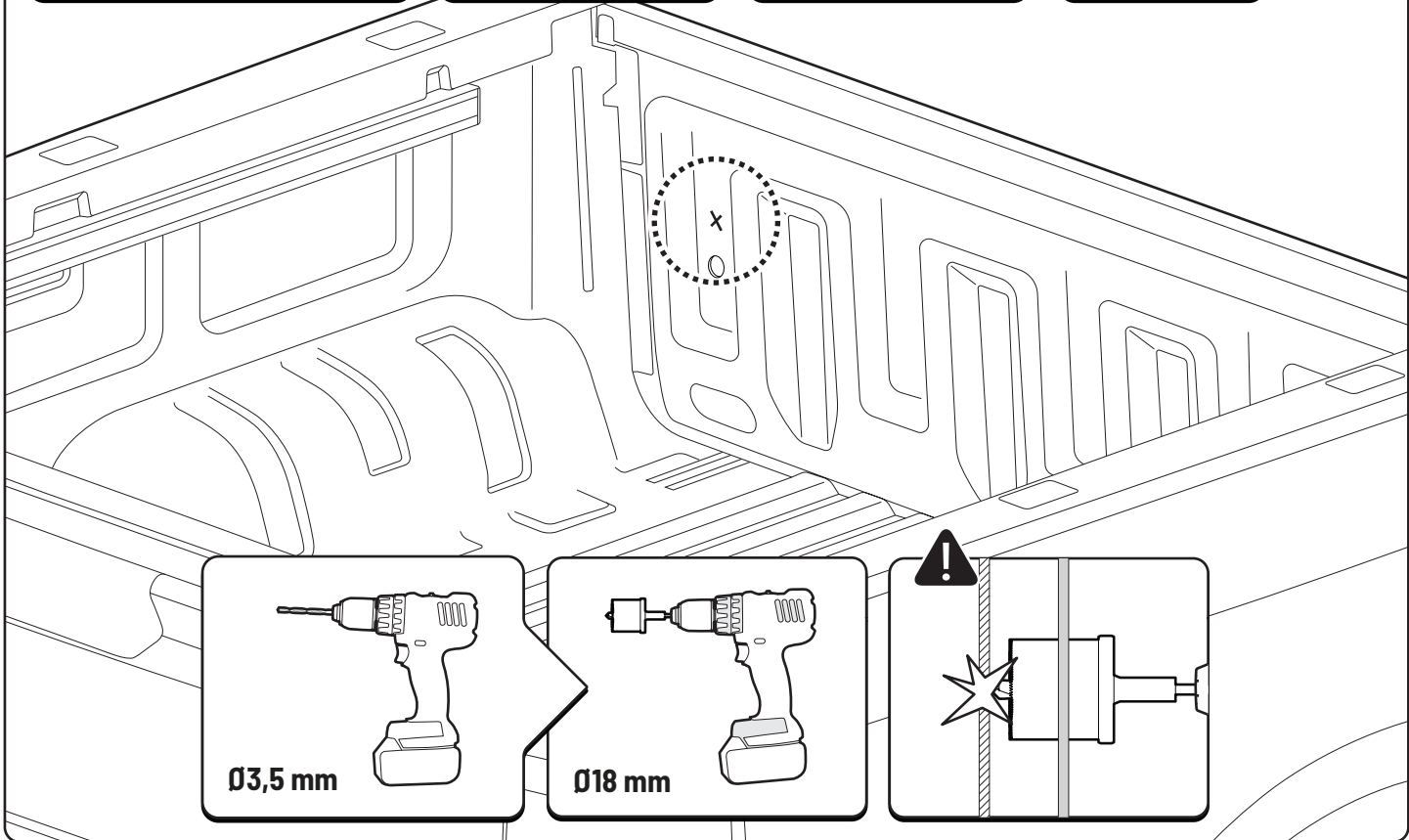
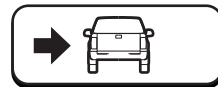

! ONLY WITHOUT LINER



! Rust Protection

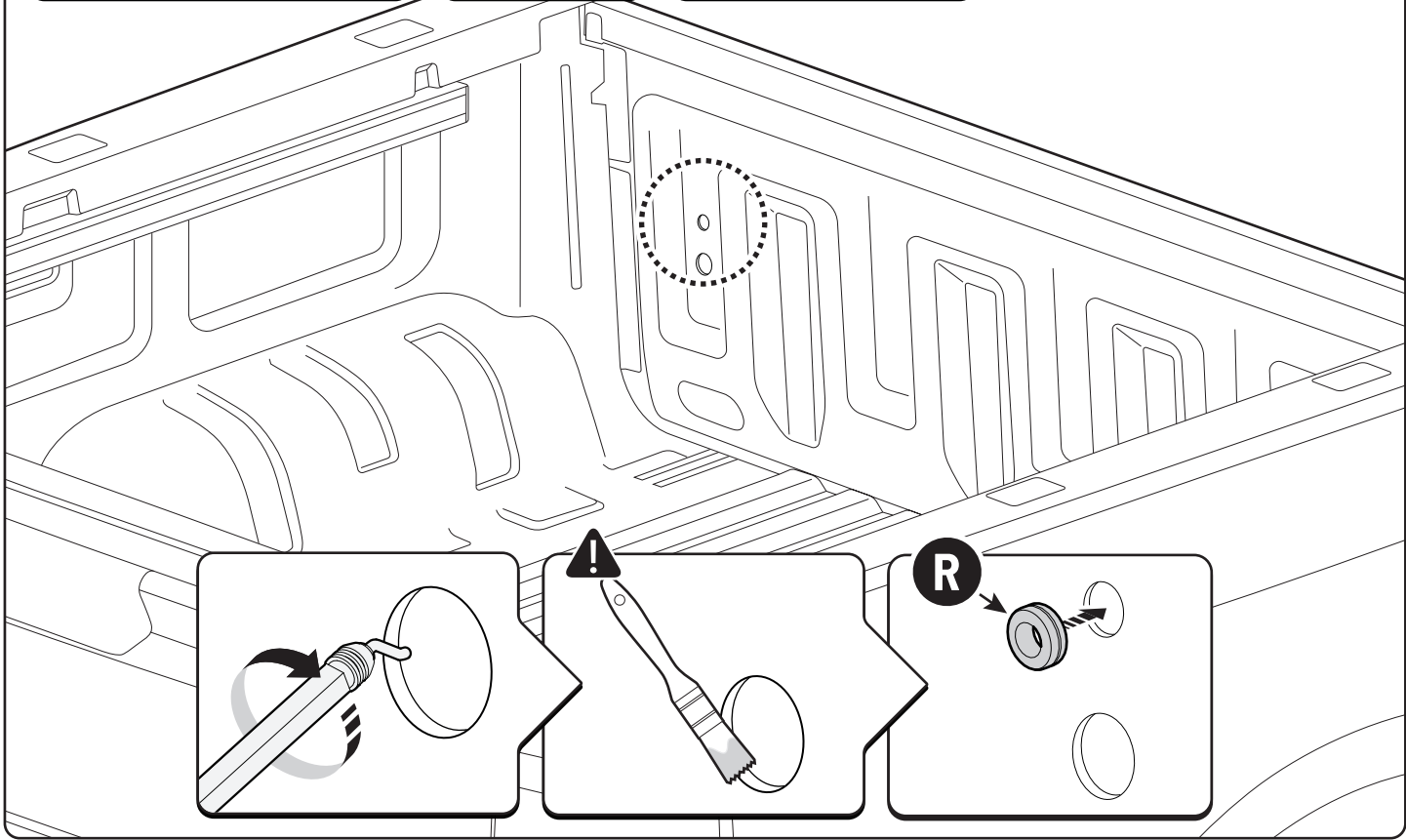

! ONLY WITHOUT LINER

A: 55 mm B: 380 mm

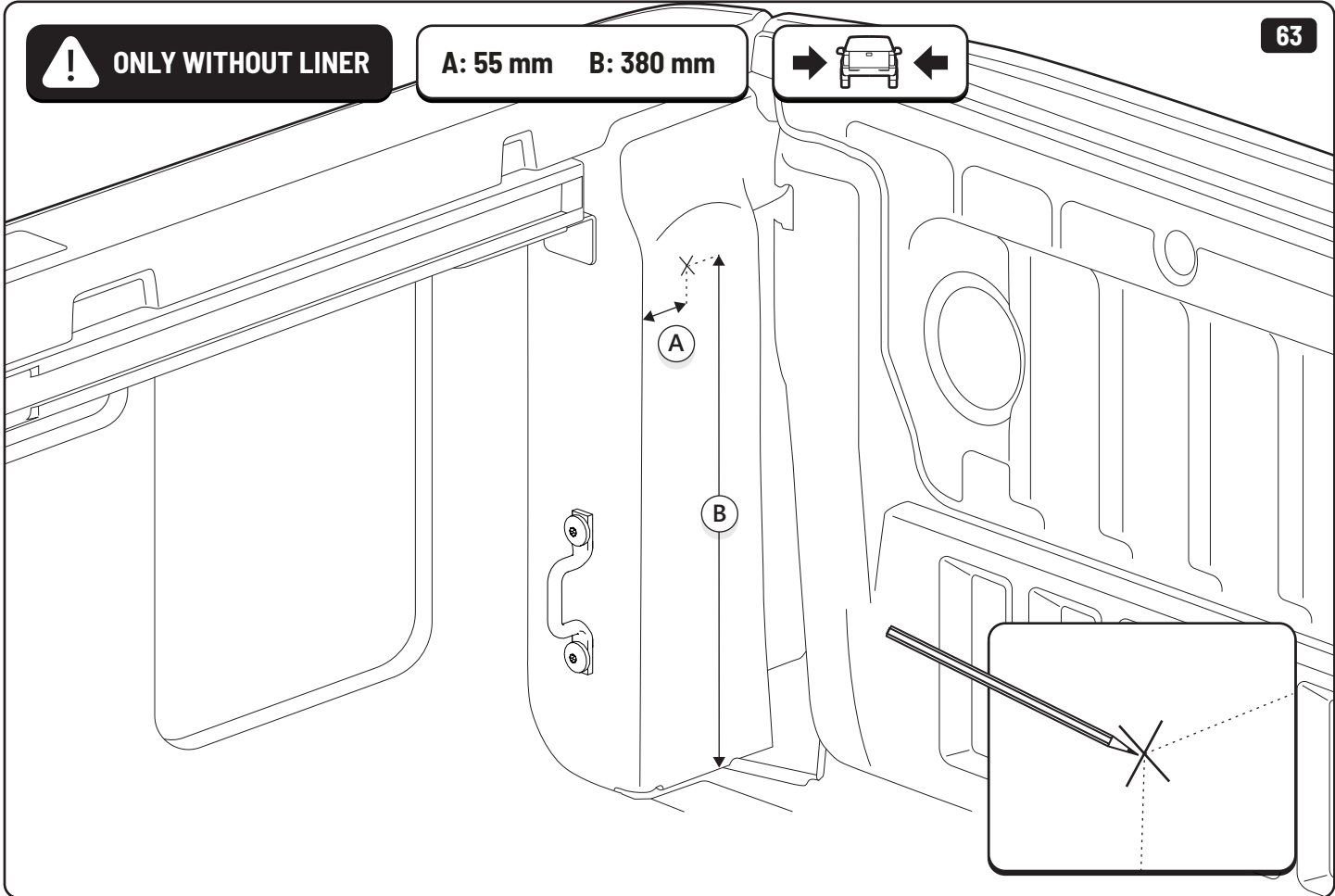

! ONLY WITHOUT LINER

 **Ø30 mm**

! Rust Protection

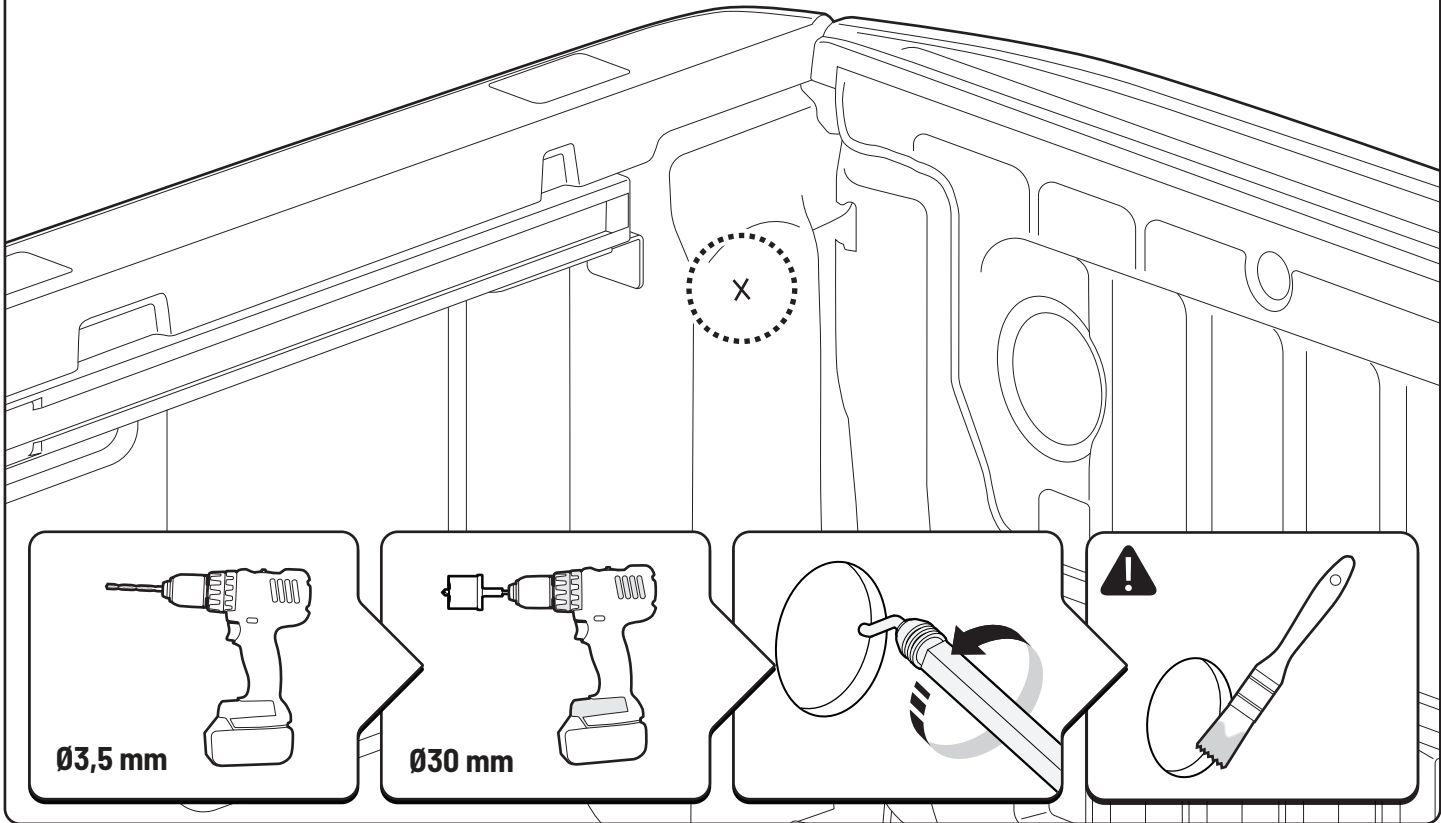

! ONLY TO BE INSTALLED BY AUTHORIZED PERSONNEL

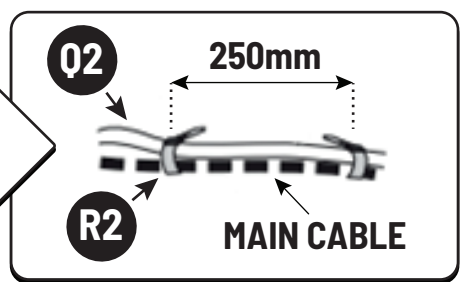
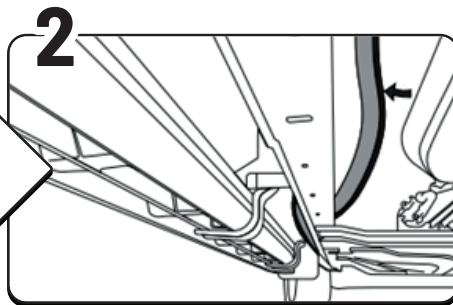
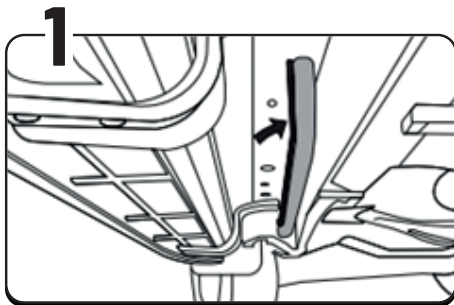
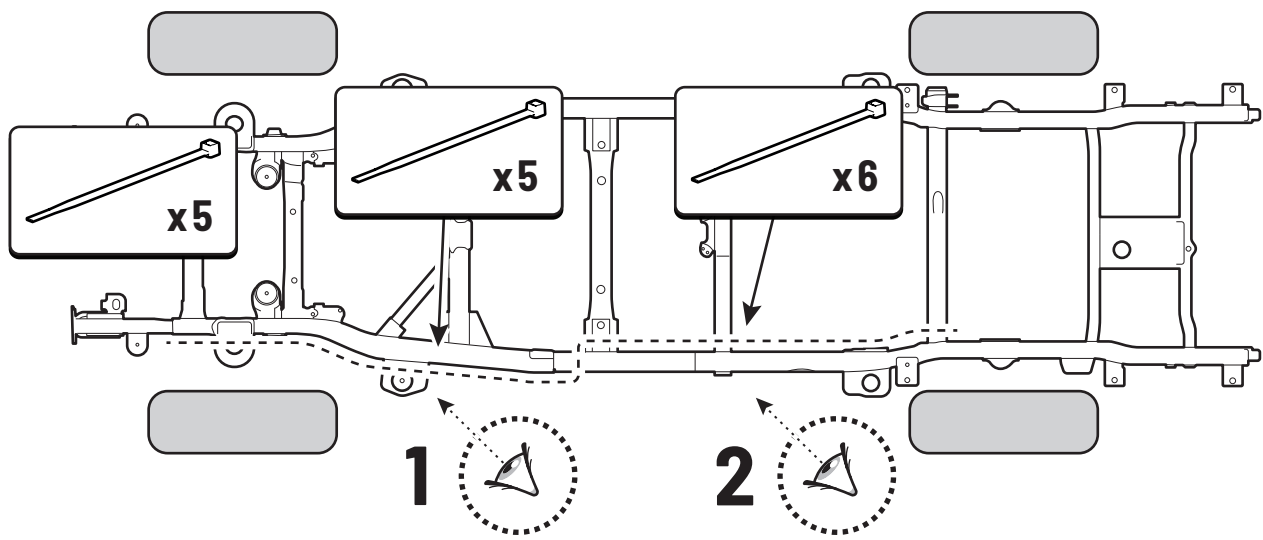
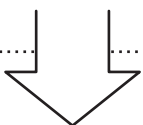
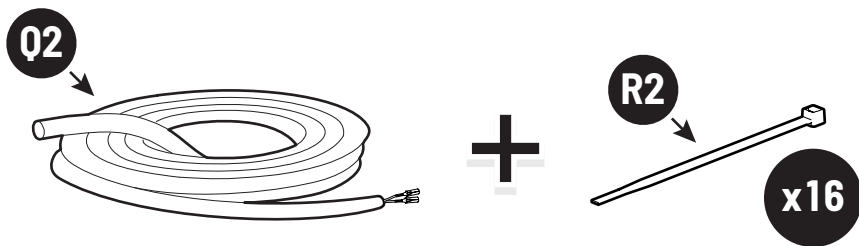
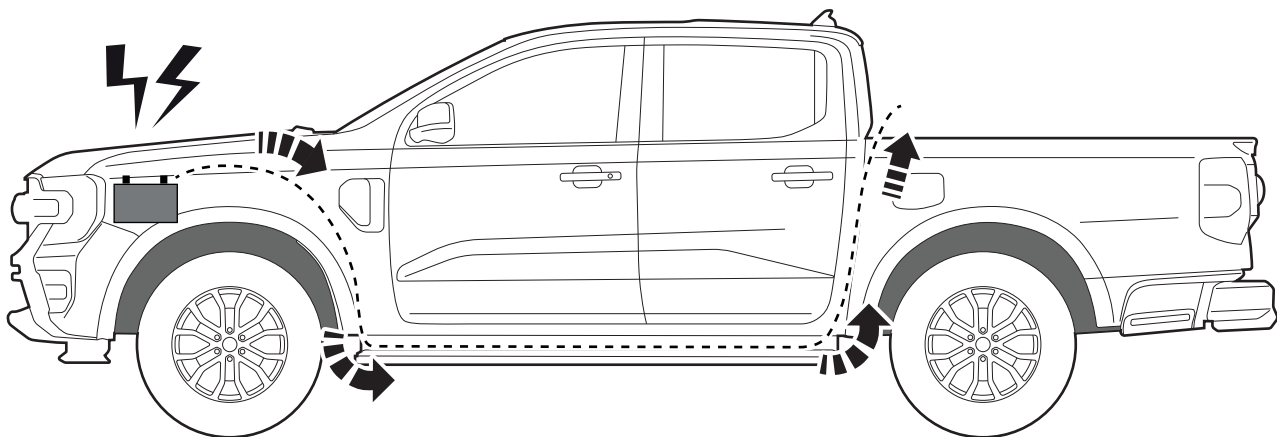

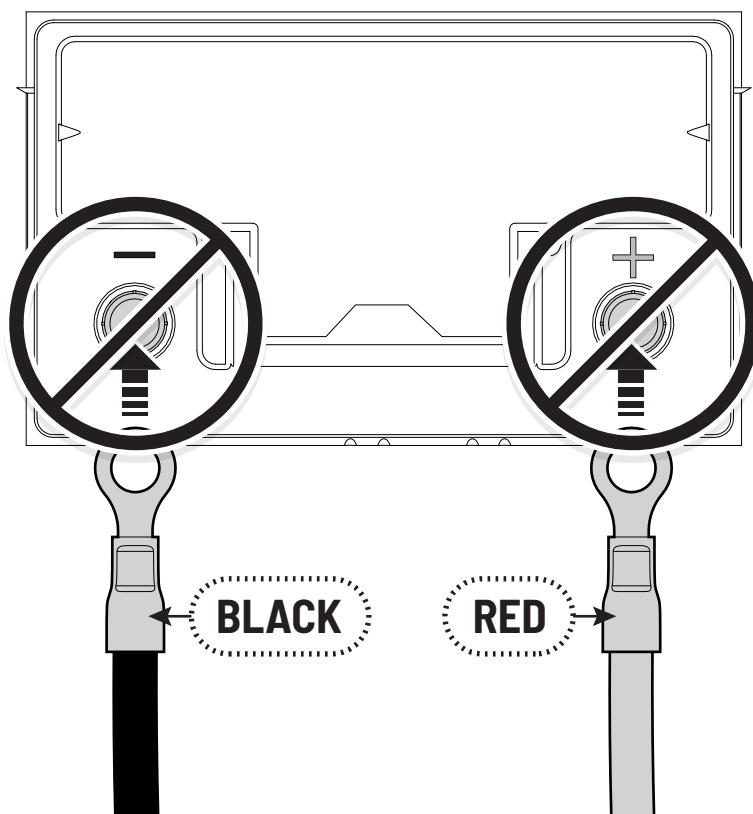
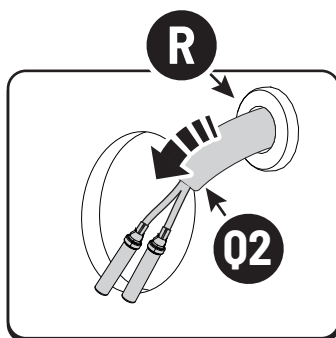
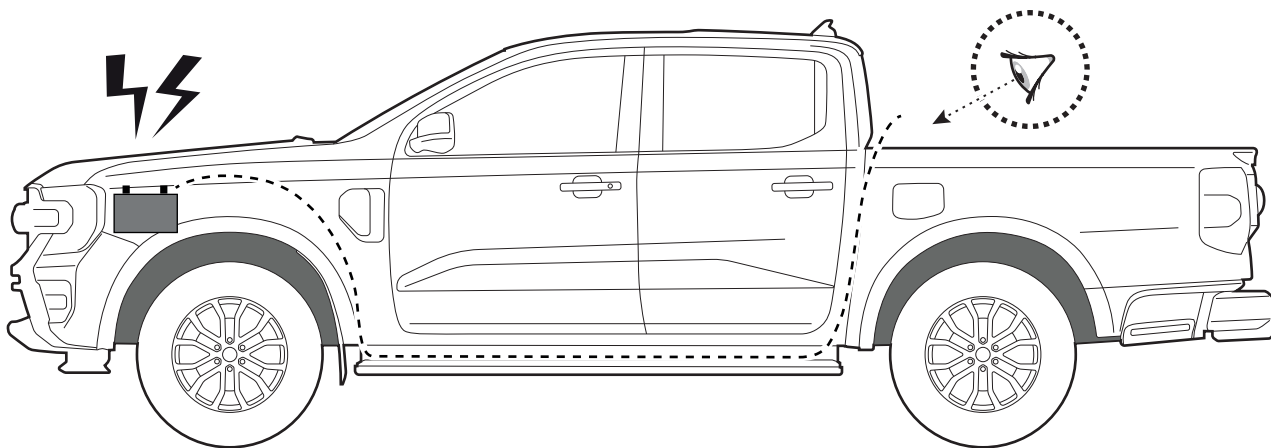

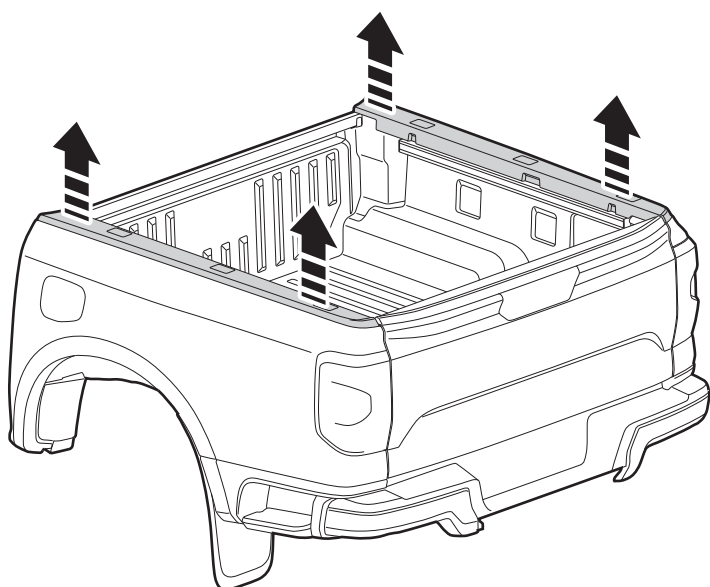

Ford XLT / Raptor

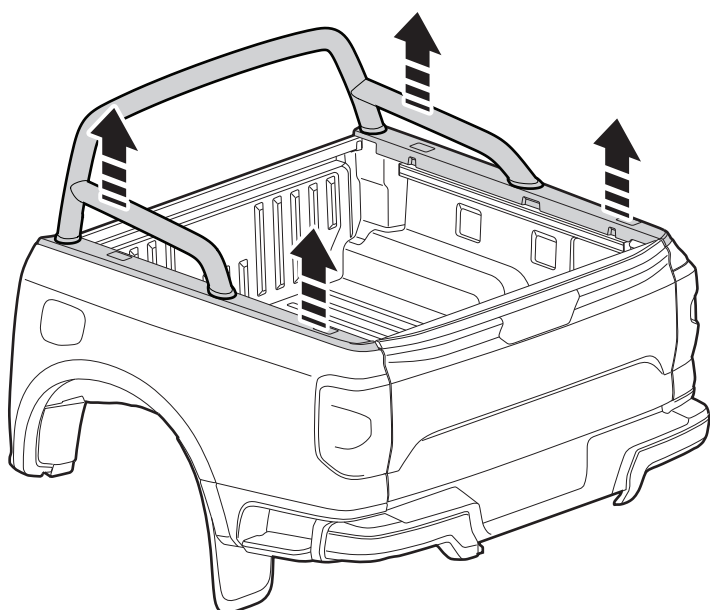

Ford XLT / Raptor

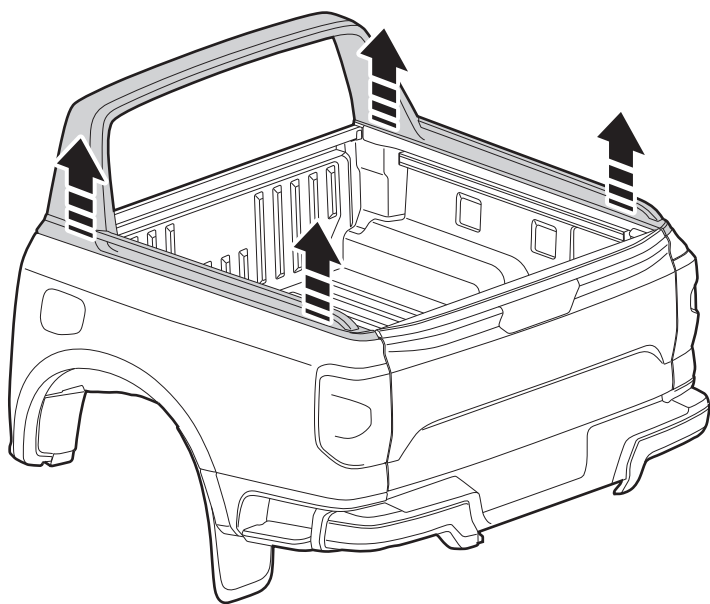

Ford Wildtrak

! ONLY FOR THREADED HOLES

LOCTITE 243

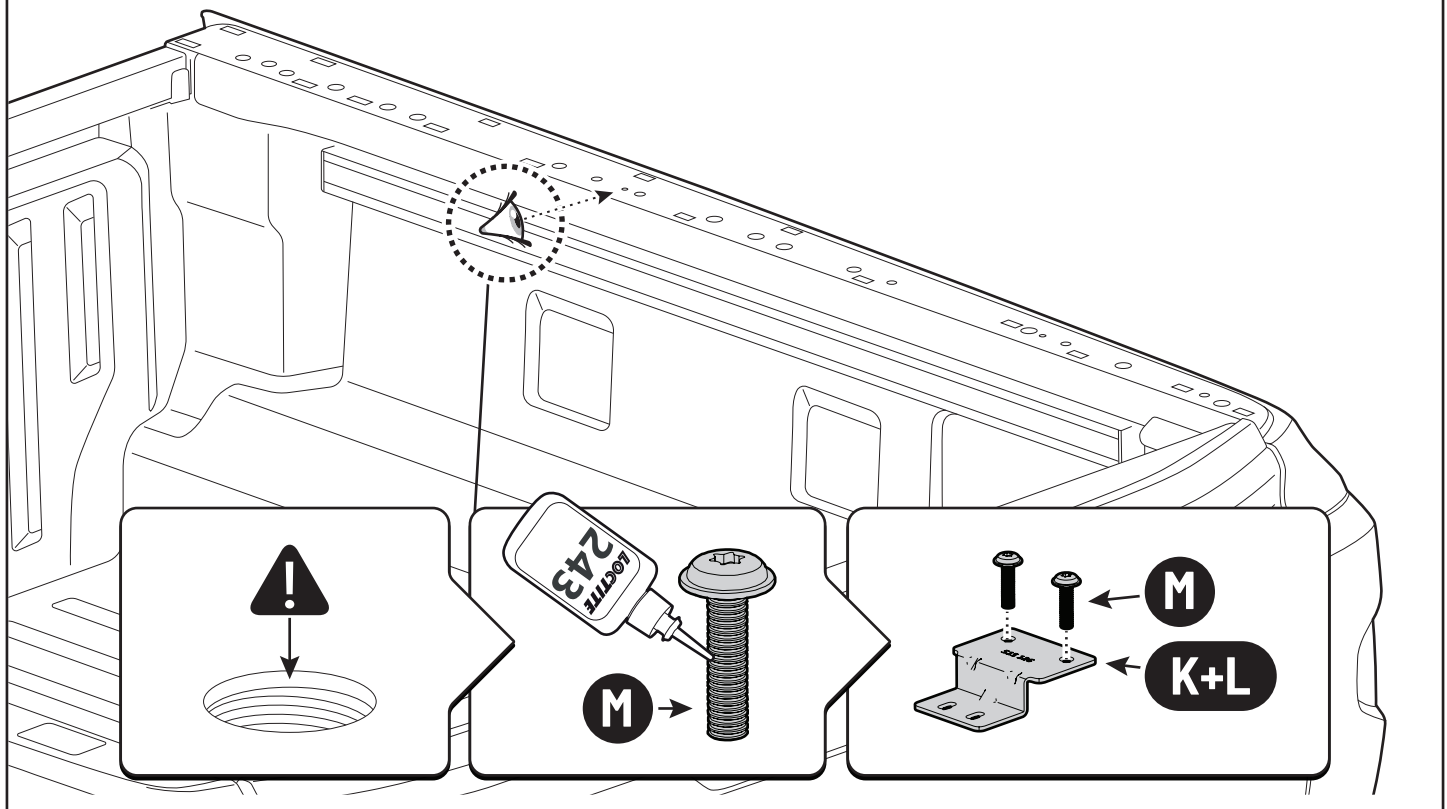

! ONLY FOR NON-THREADED HOLES

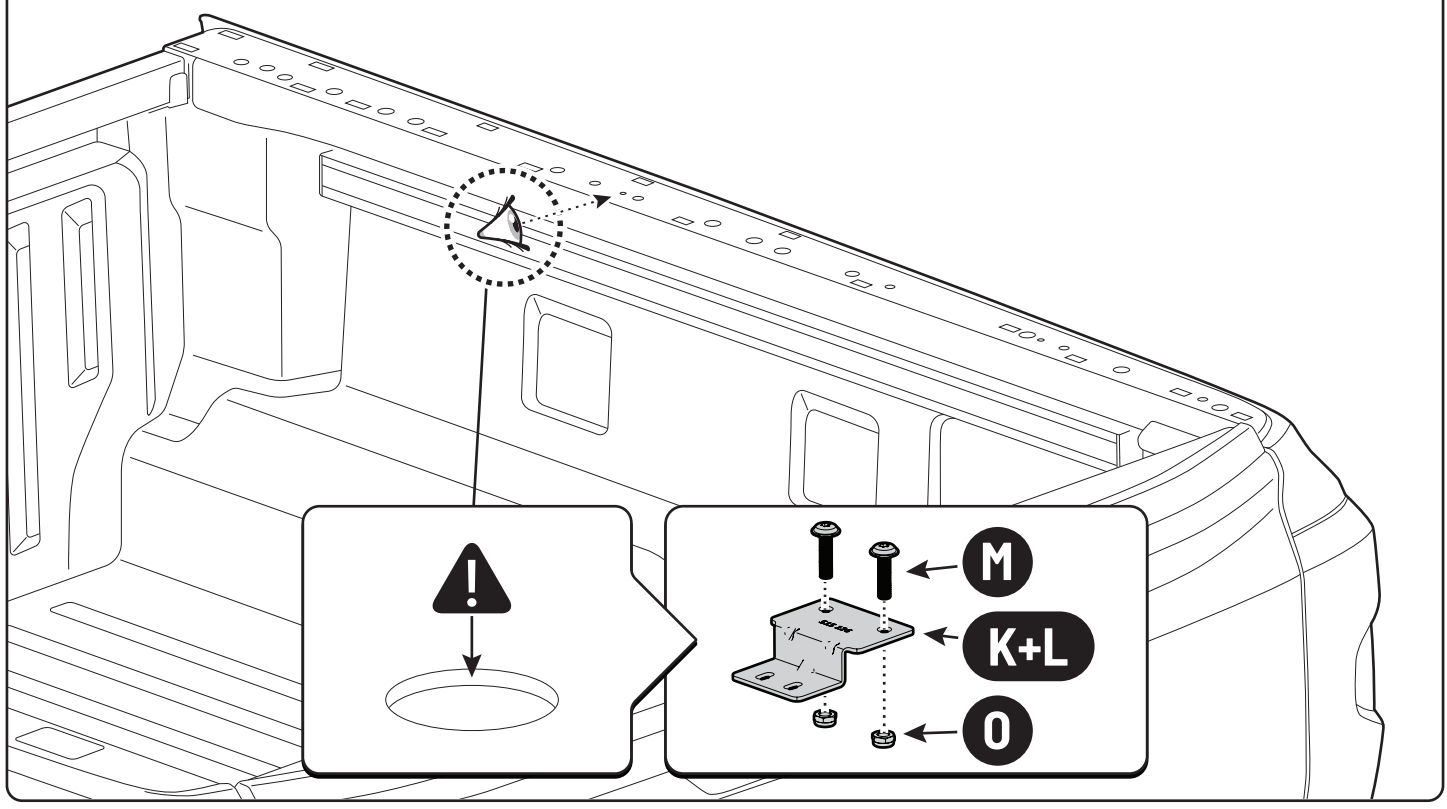

! FORD XLT / RAPTOR - DOUBLE CAB

T45 13 mm 25 Nm

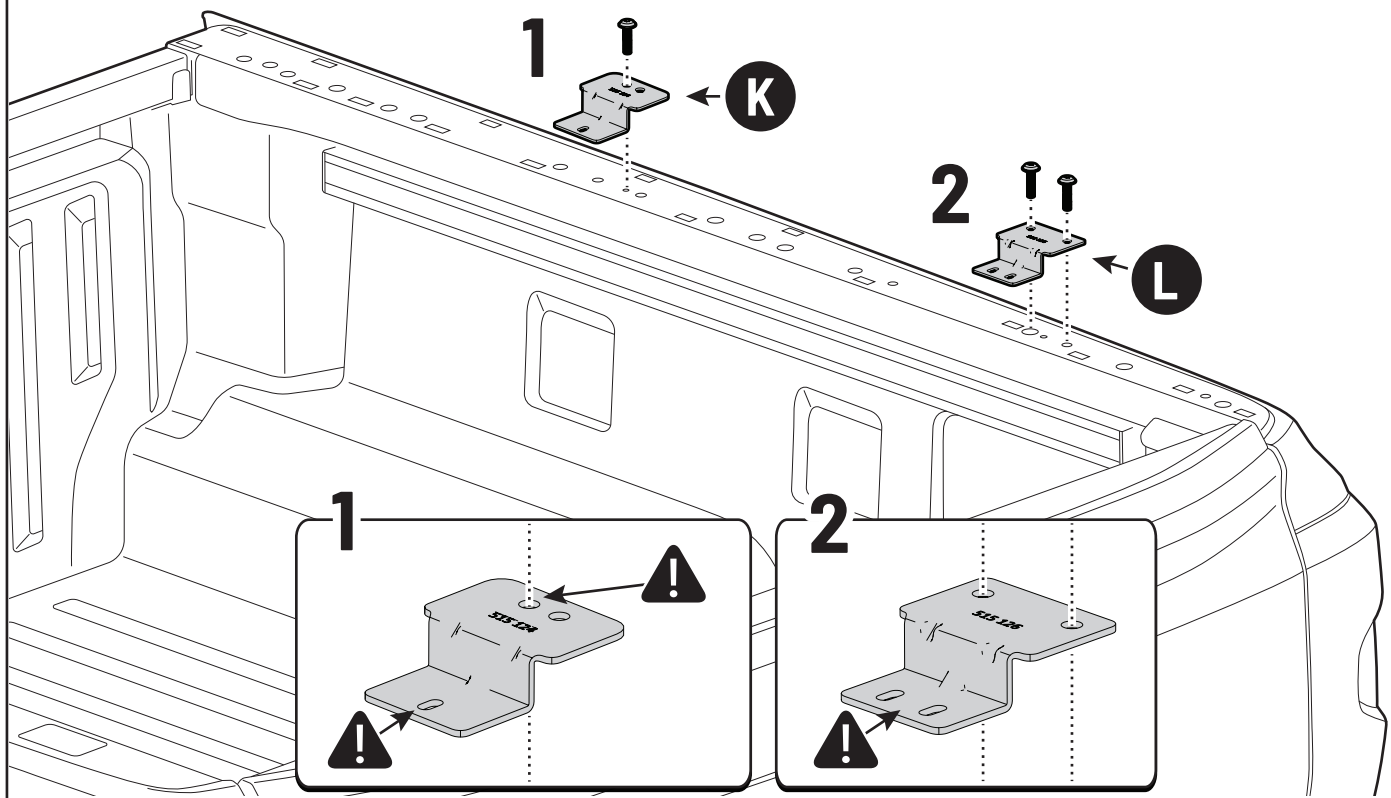
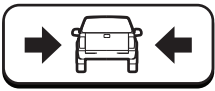

! FORD WILDTRAK - DOUBLE CAB

T45 13 mm 25 Nm

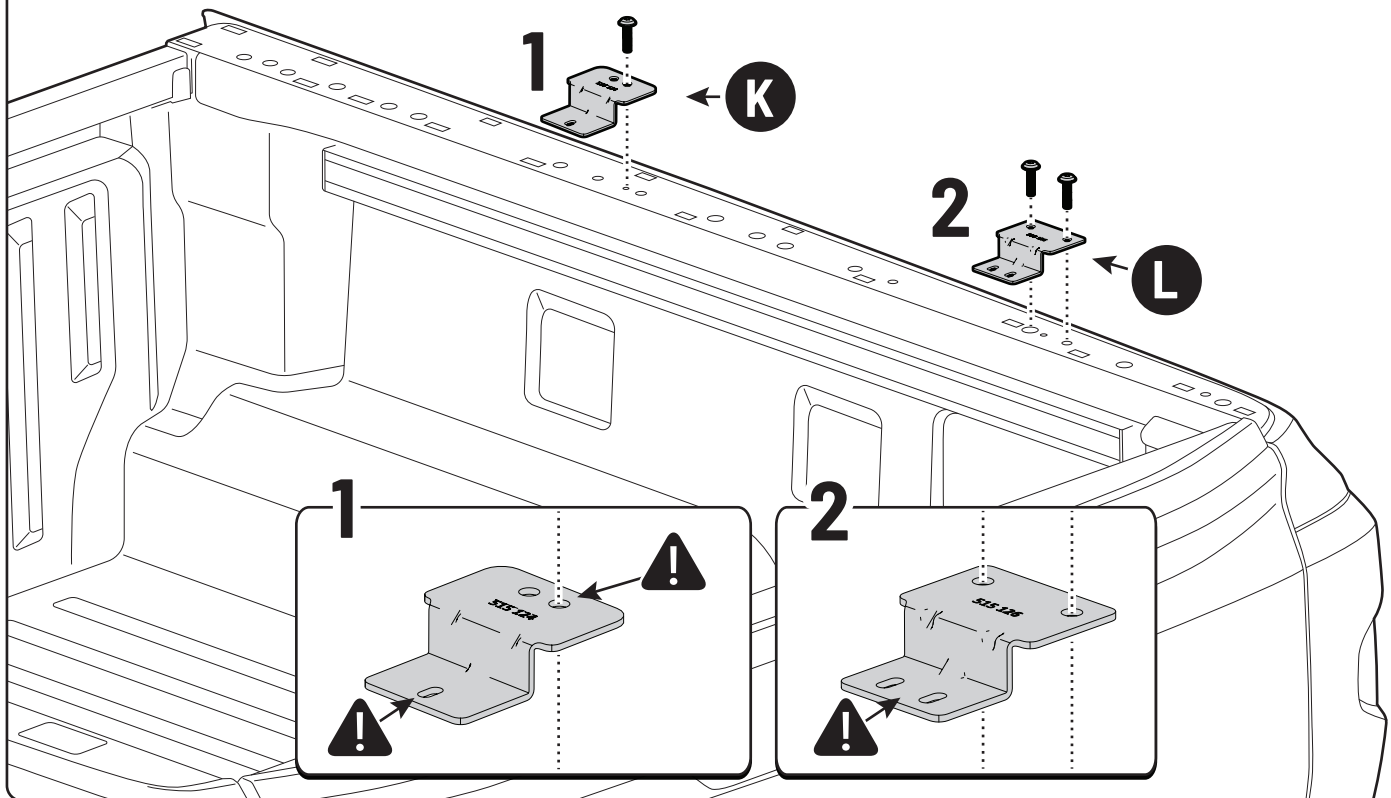
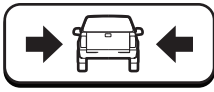

! WITH SPORTS BAR ACCESSORY - RAP CAB

T45 13 mm 25 Nm

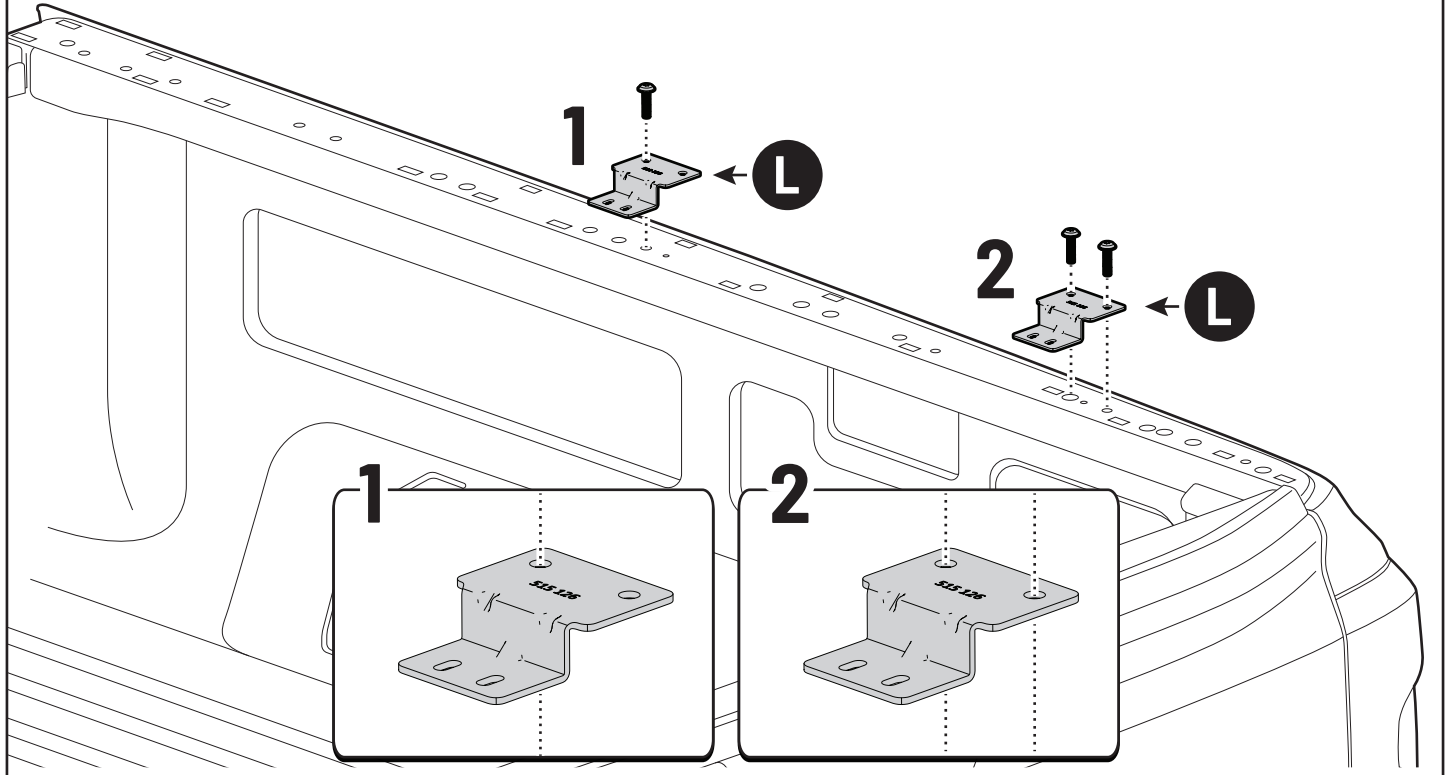
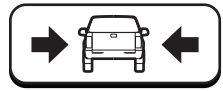

! WITHOUT SPORTS BAR ACCESSORY - RAP CAB

T45 13 mm 25 Nm

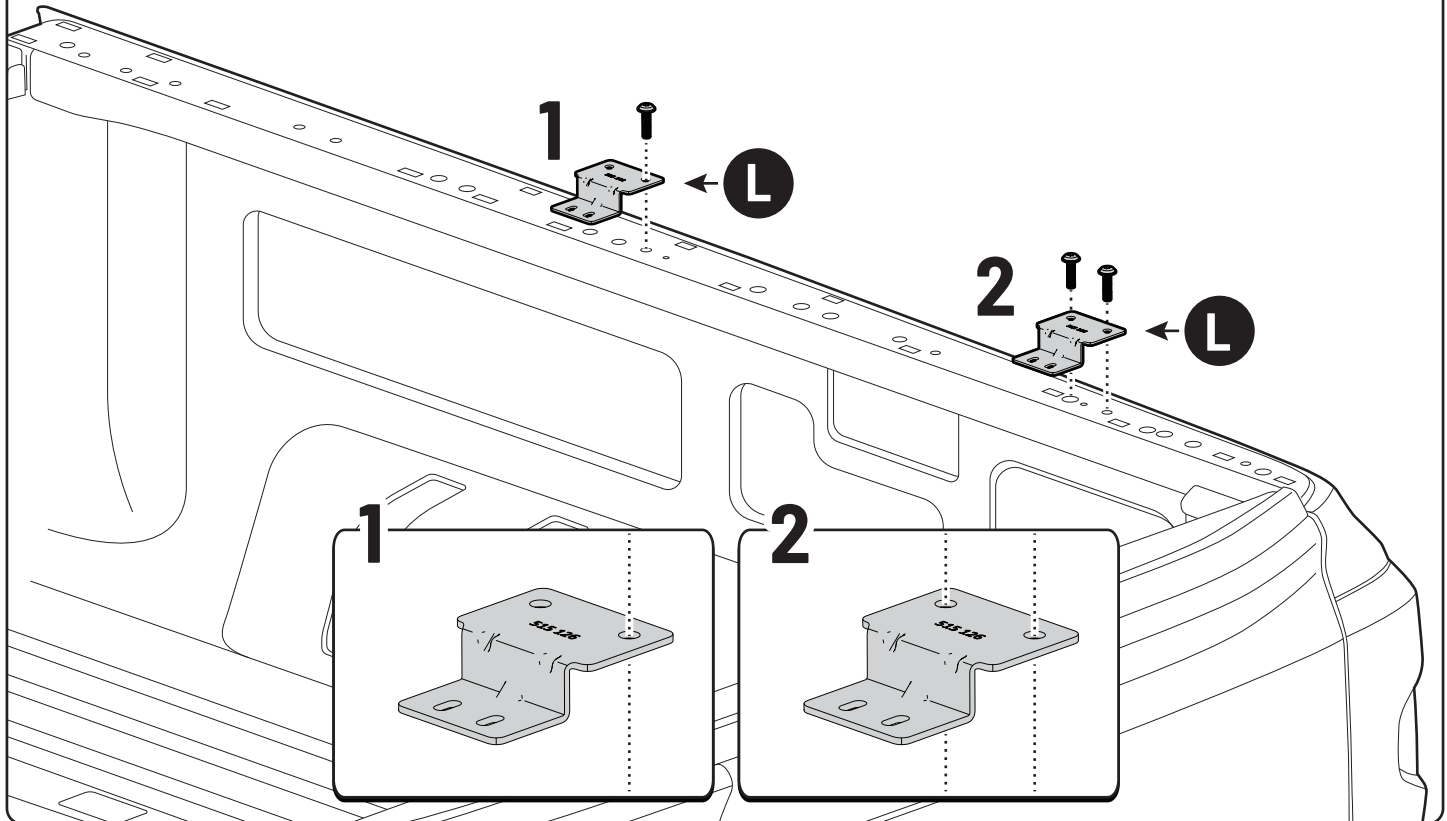
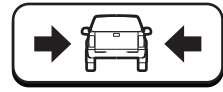

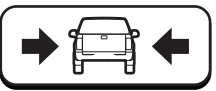

! ONLY FOR FORD RANGER XLT / RAPTOR

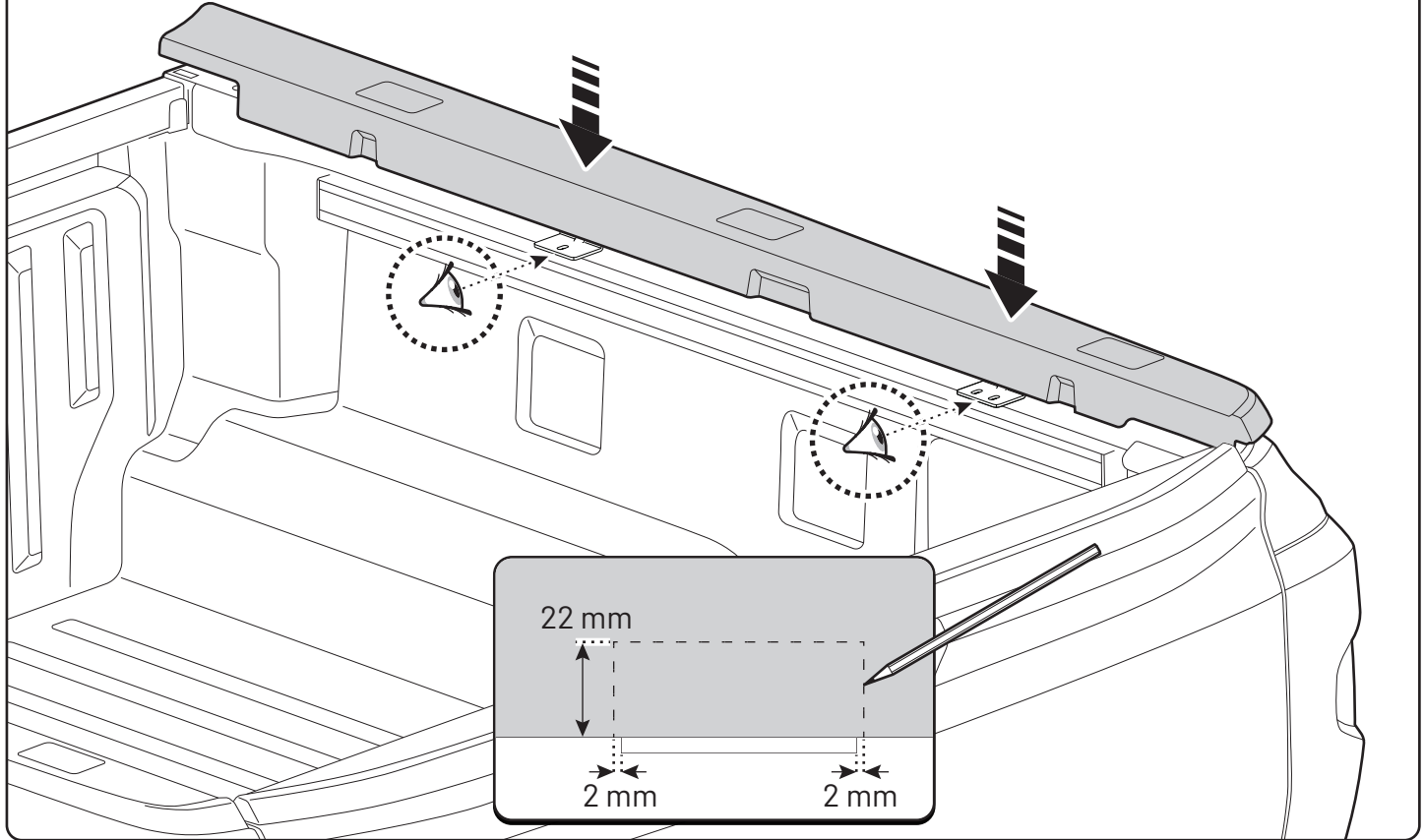

! ONLY FOR FORD RANGER XLT / RAPTOR

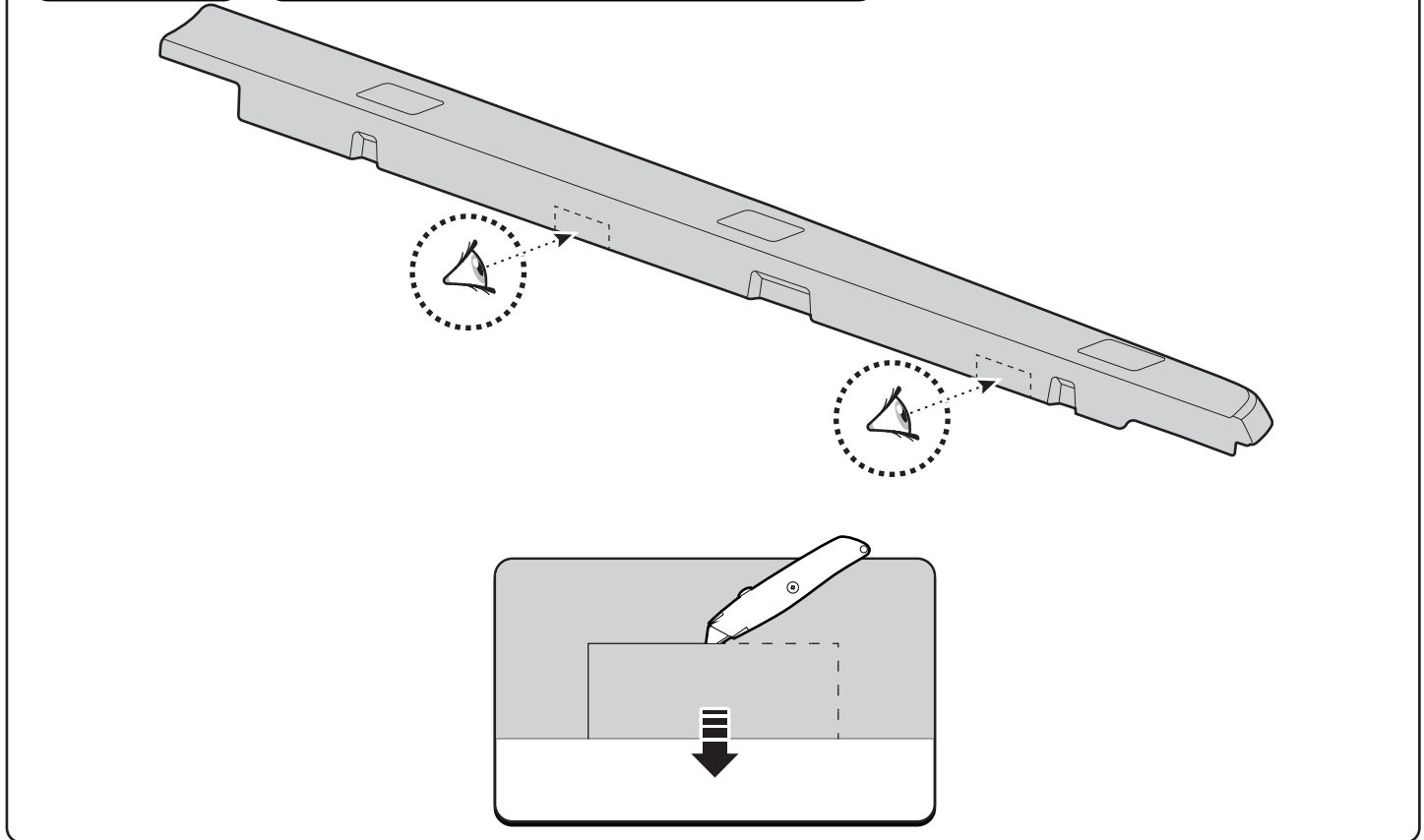

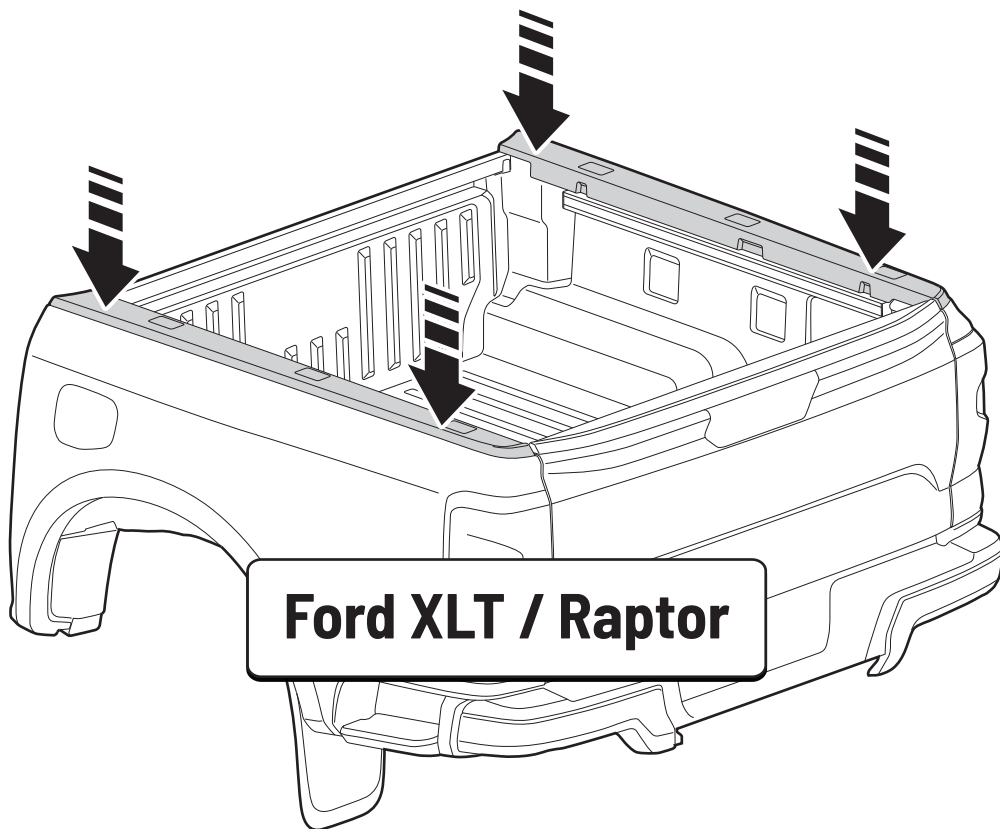

Ford XLT / Raptor

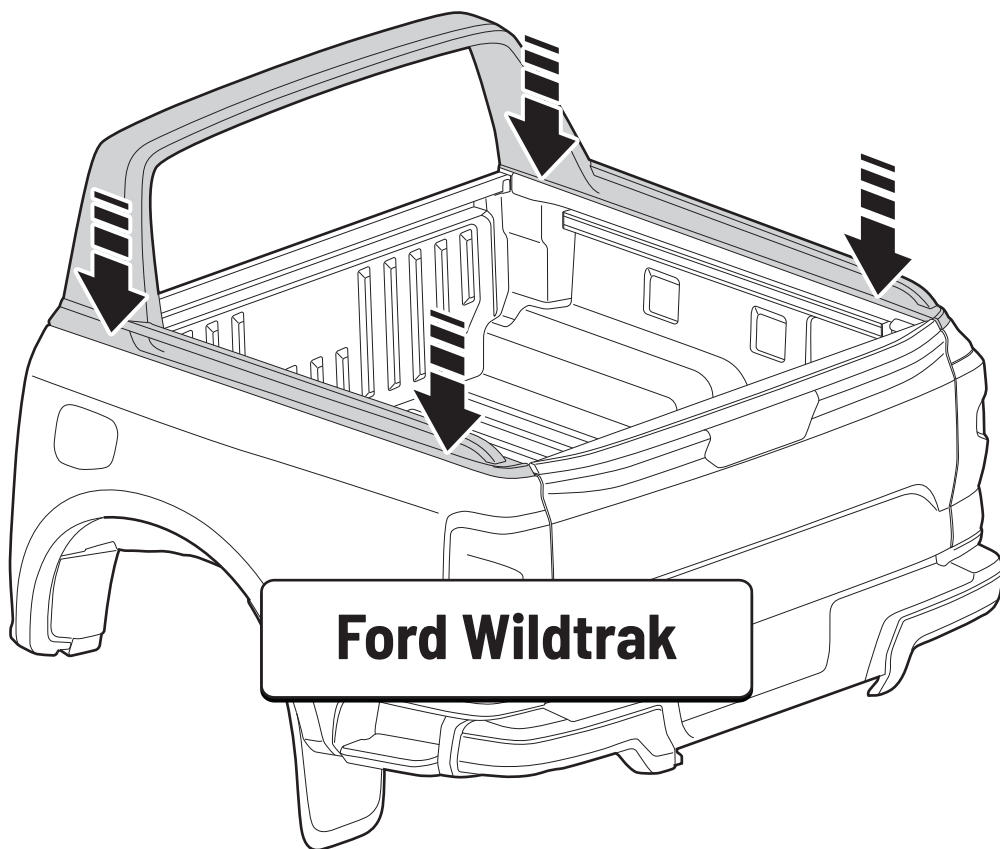

Ford Wildtrak

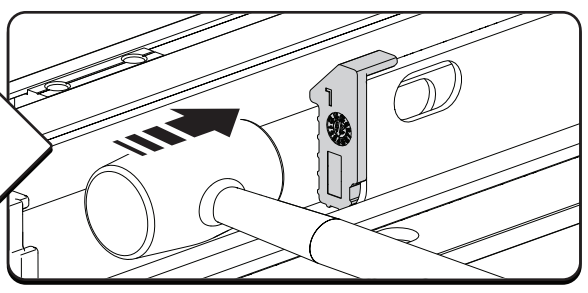
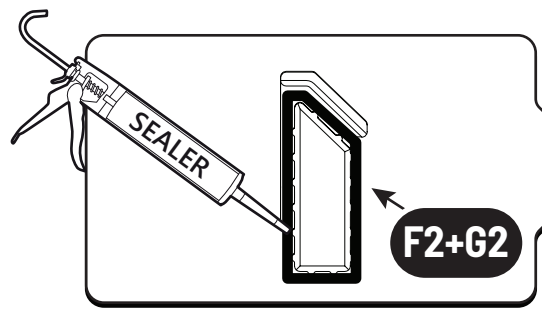
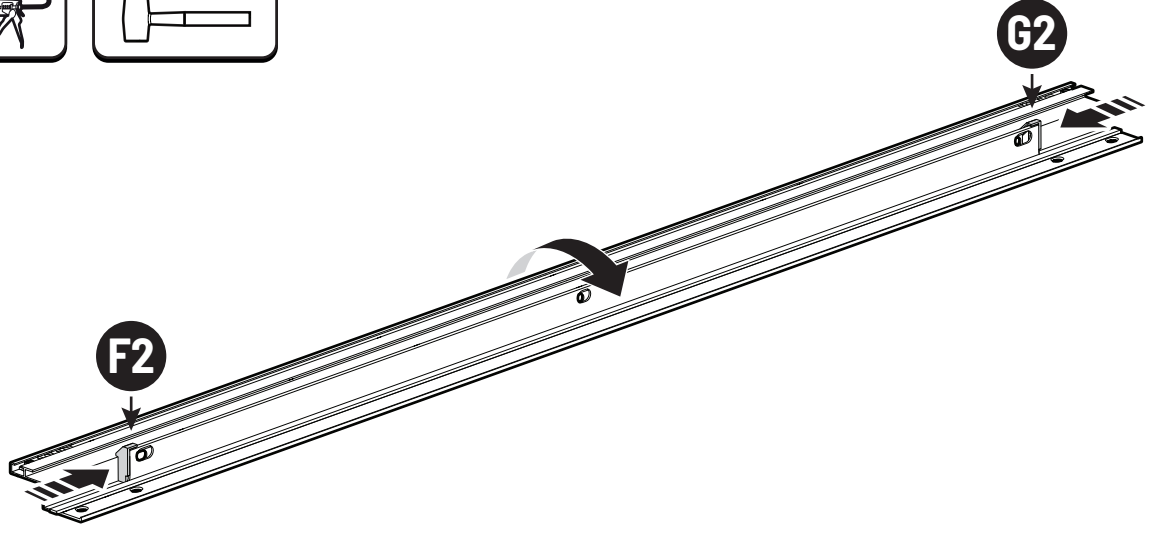
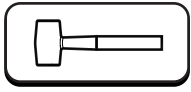
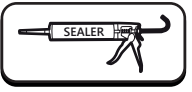
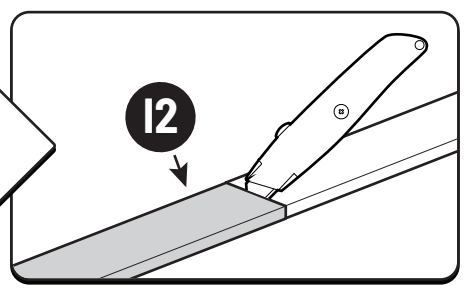
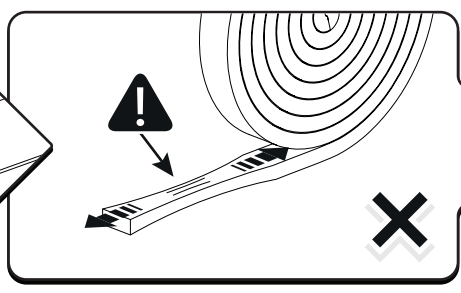
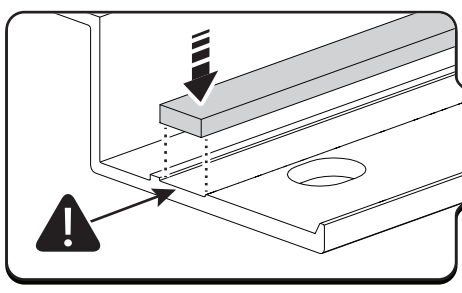
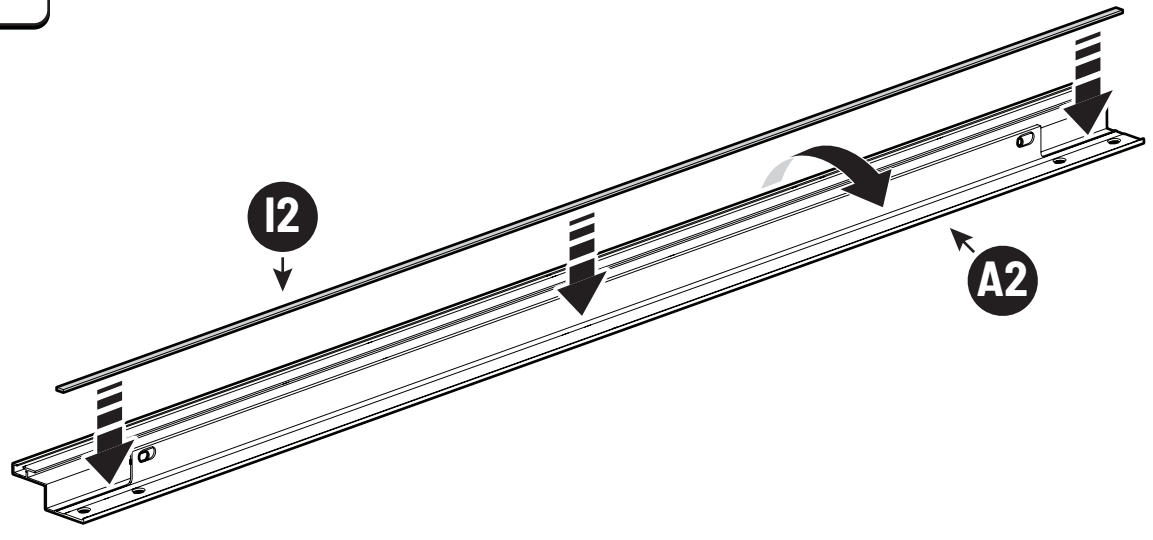
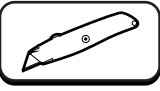

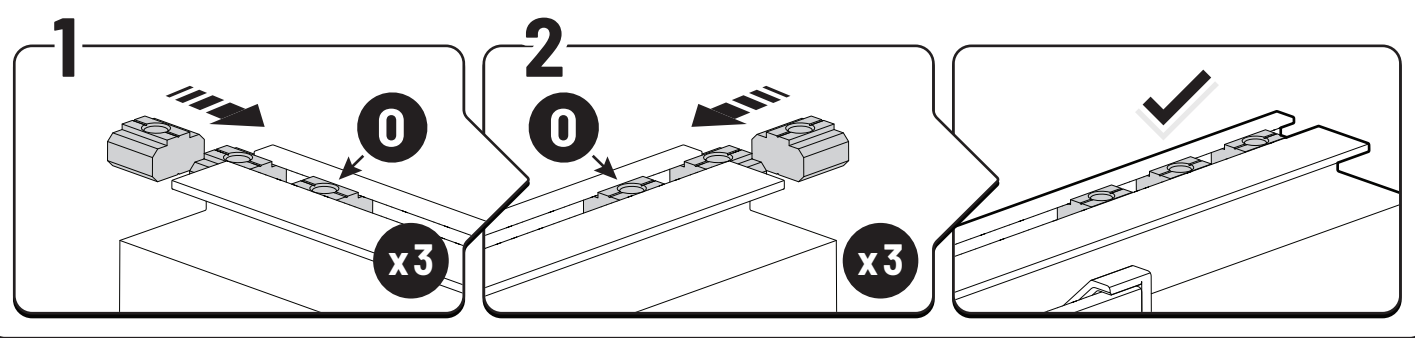
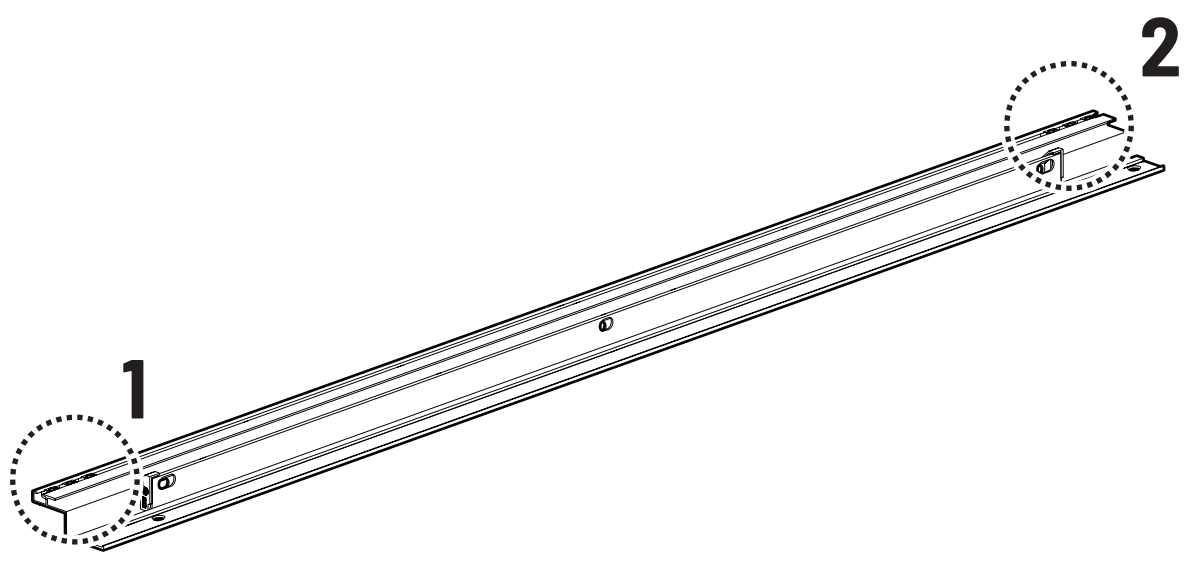

 **Super Glue (CA)**

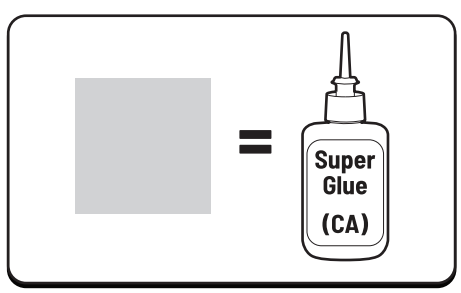
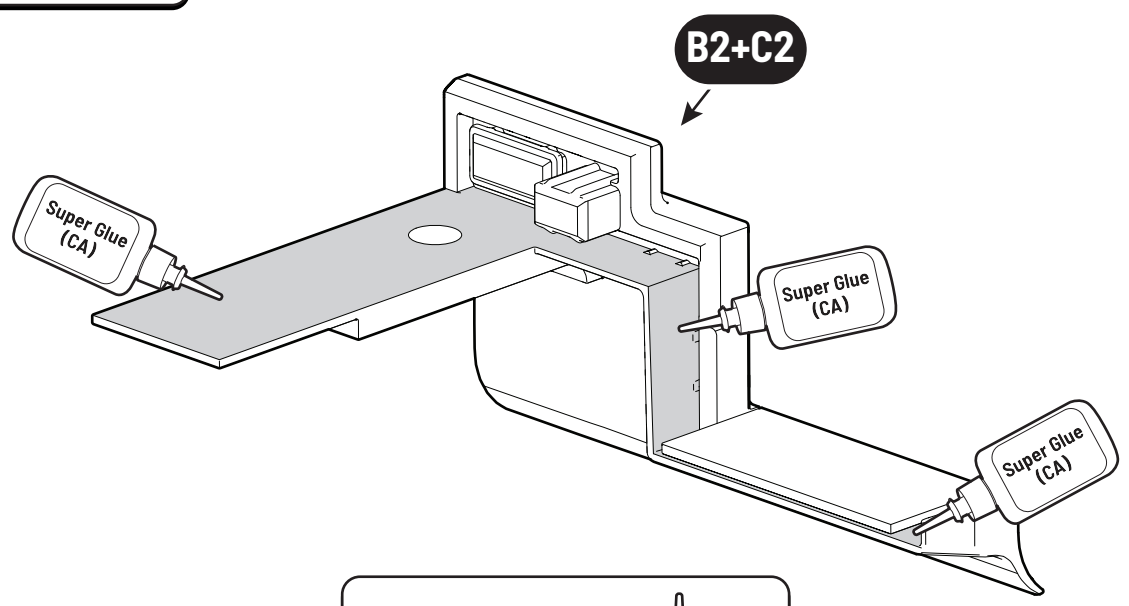



Super Glue (CA)

79

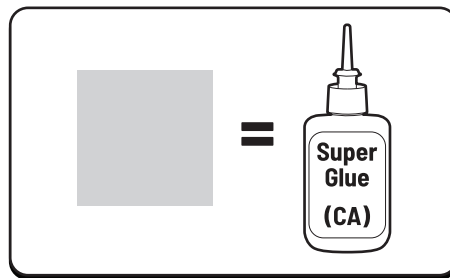
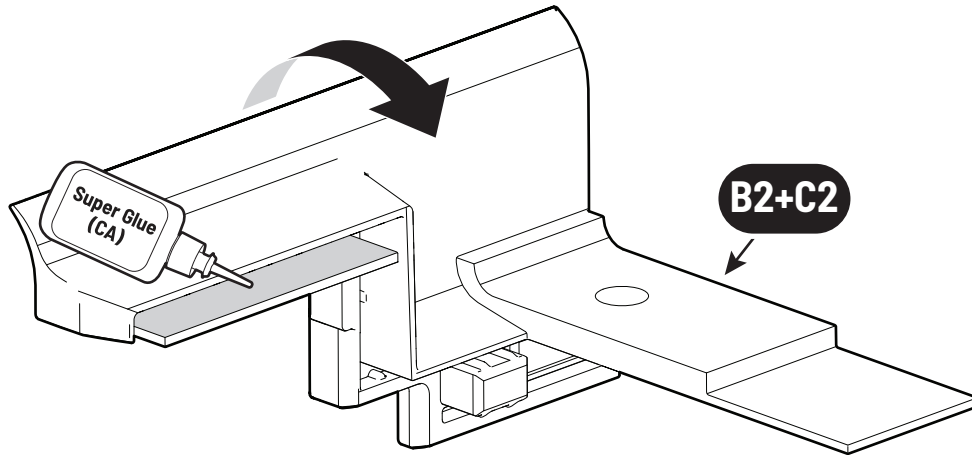

80

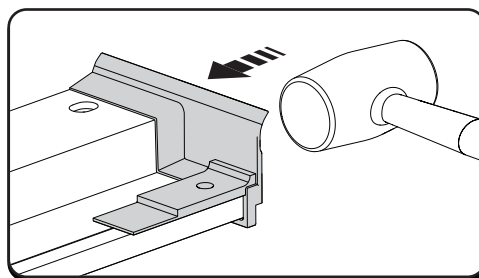
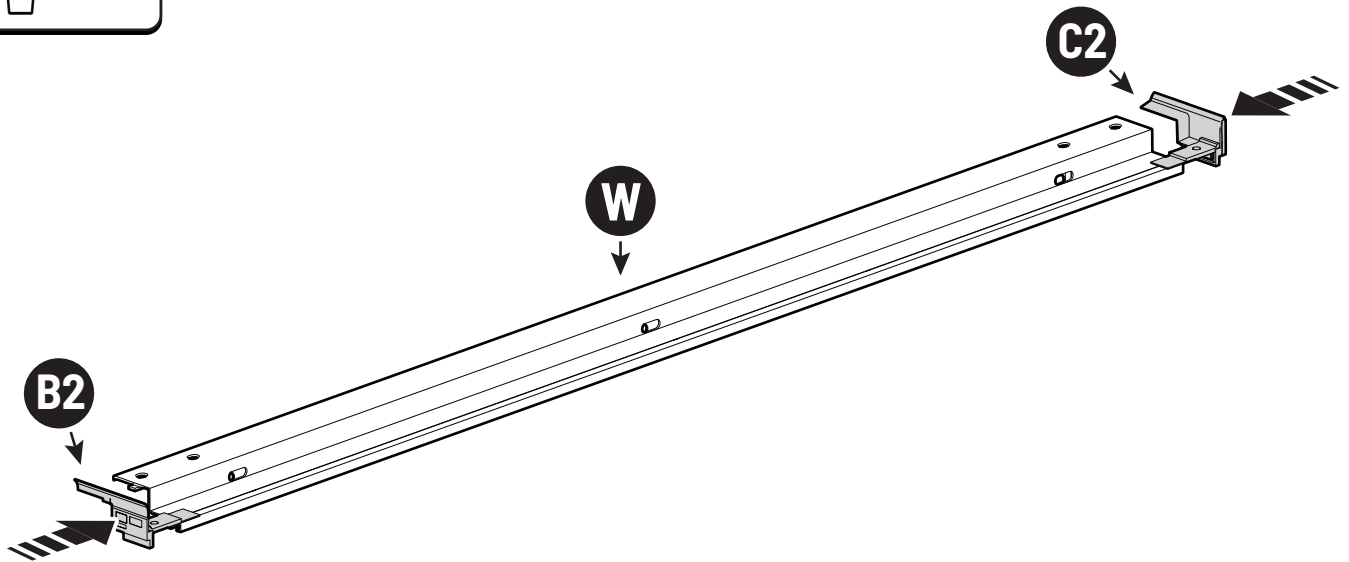

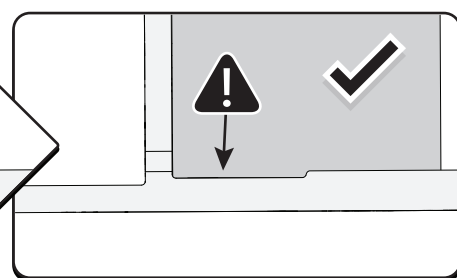
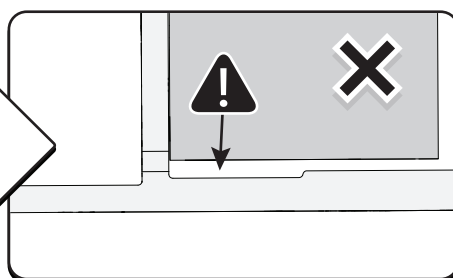
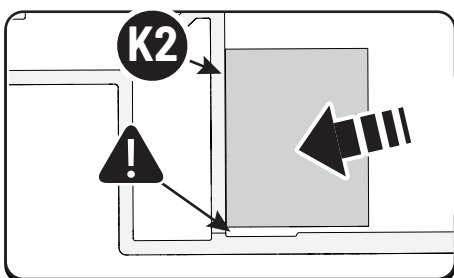
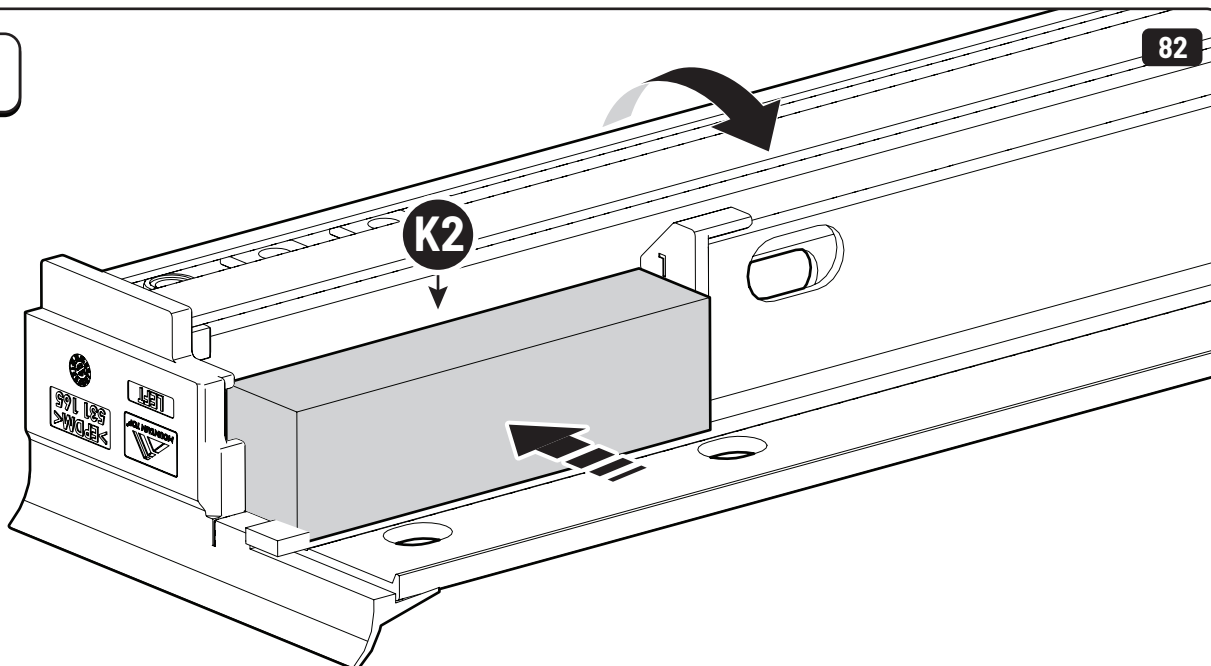
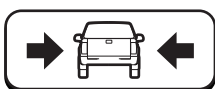
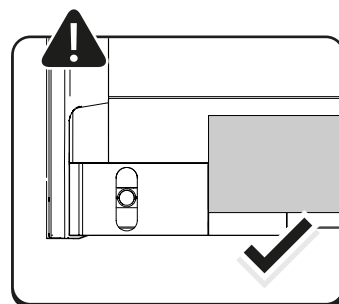
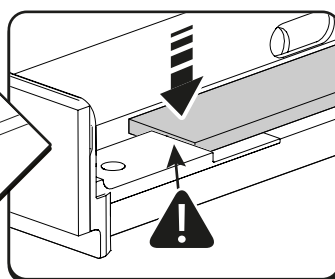
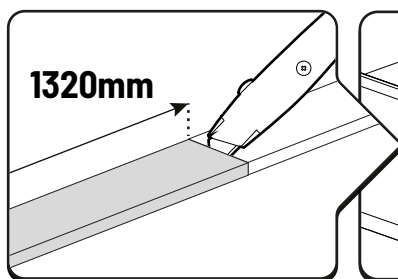
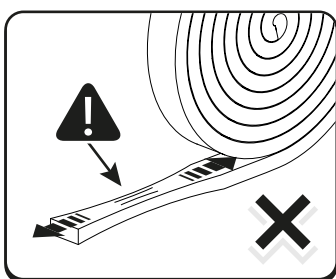
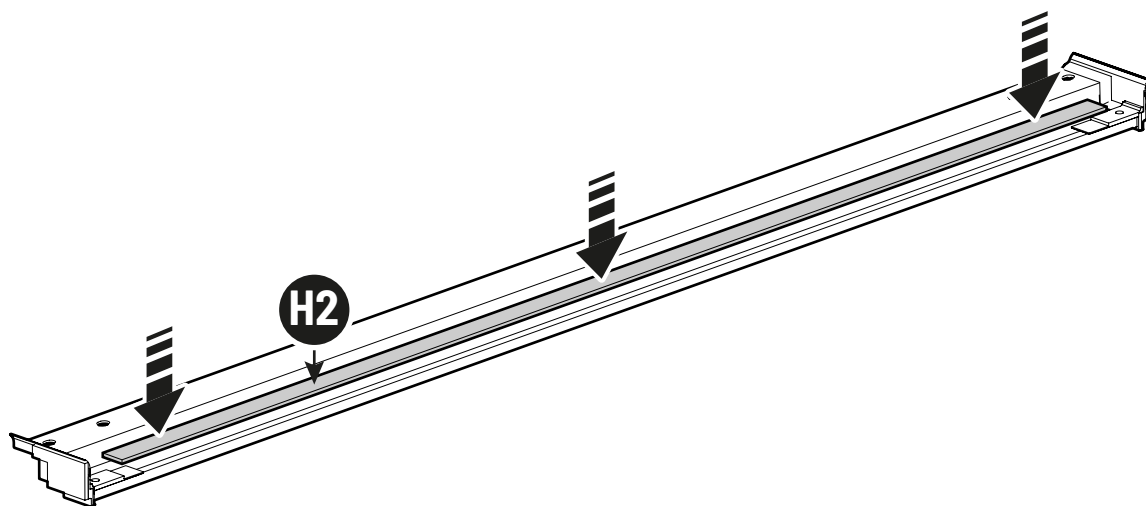

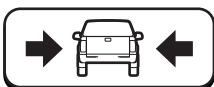
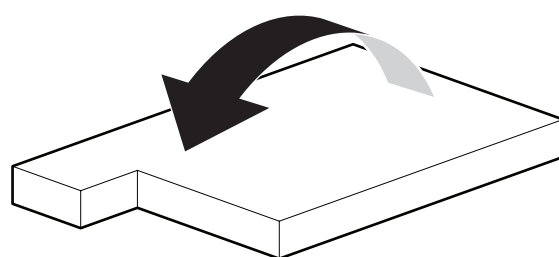
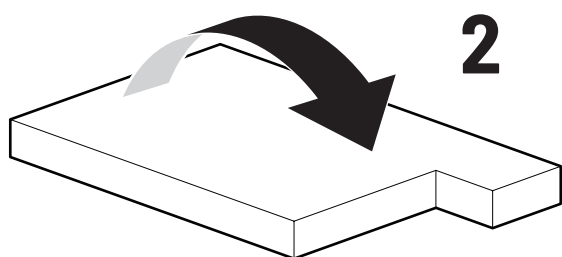
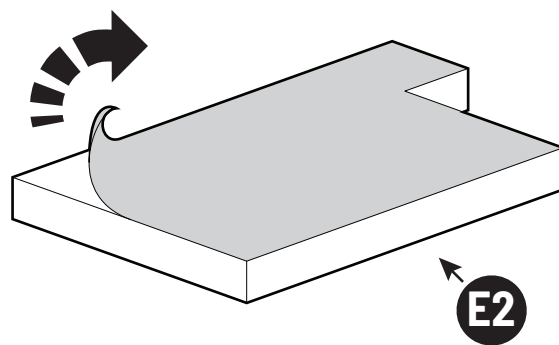
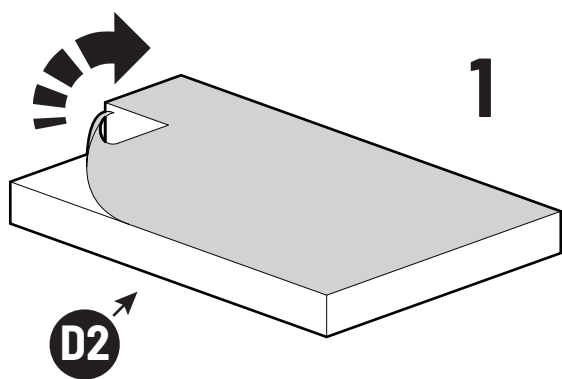

D2+E2

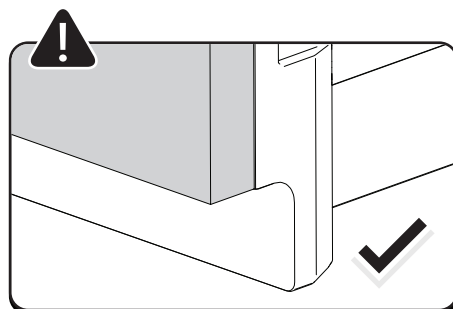
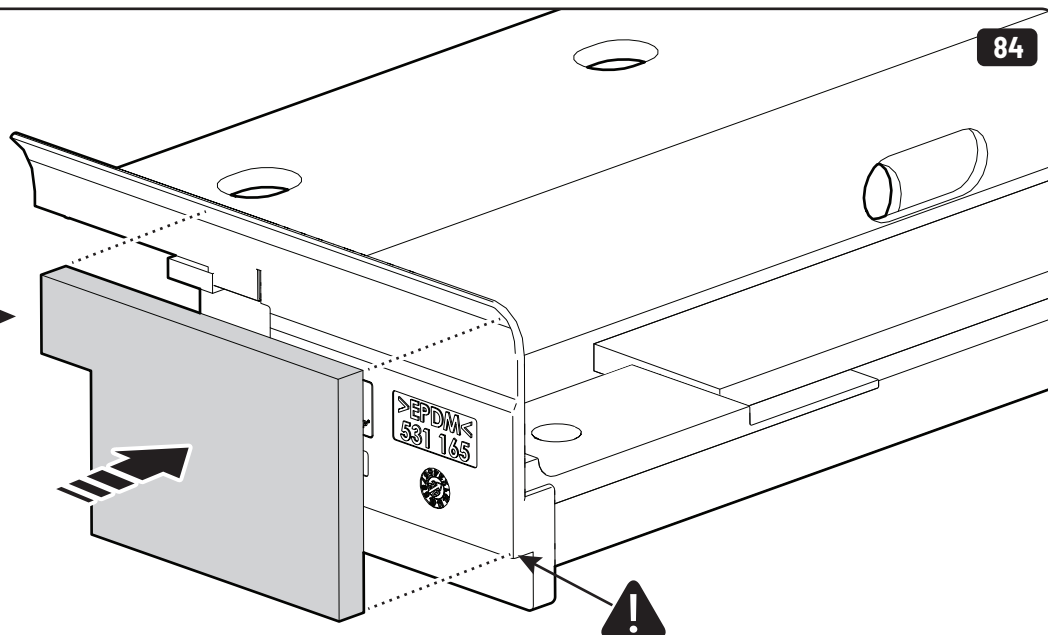

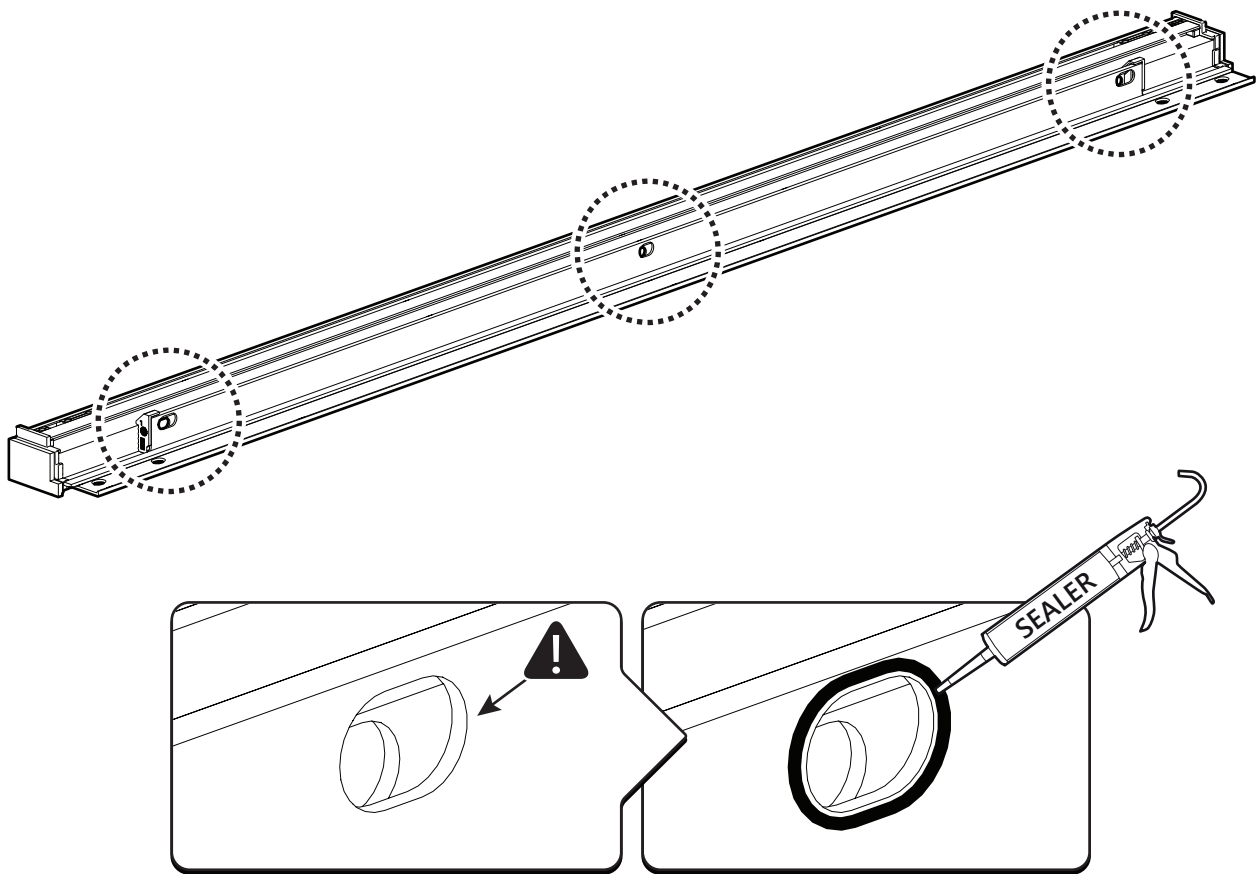

 **LOCTITE 243**

 **T45**

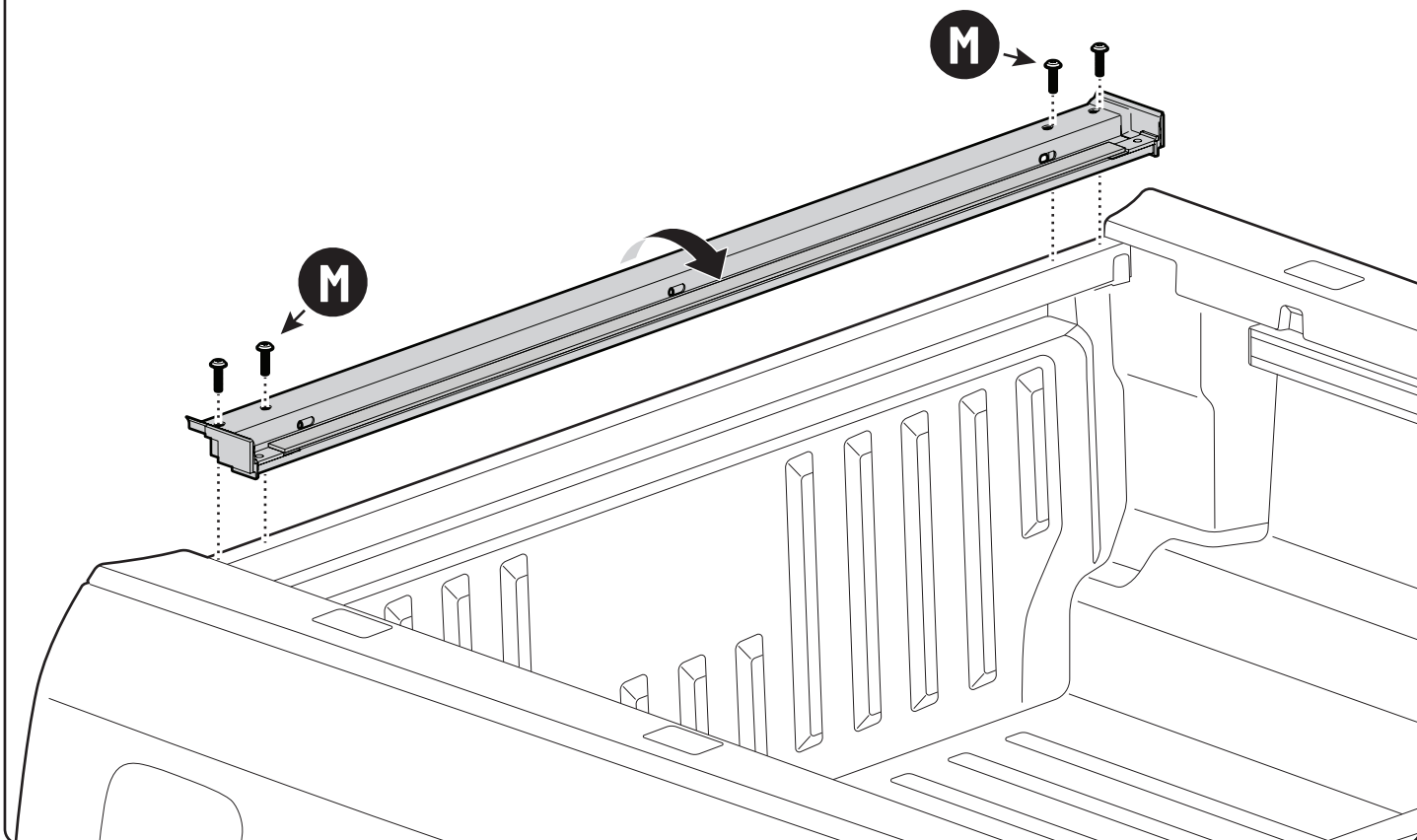

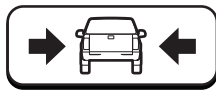
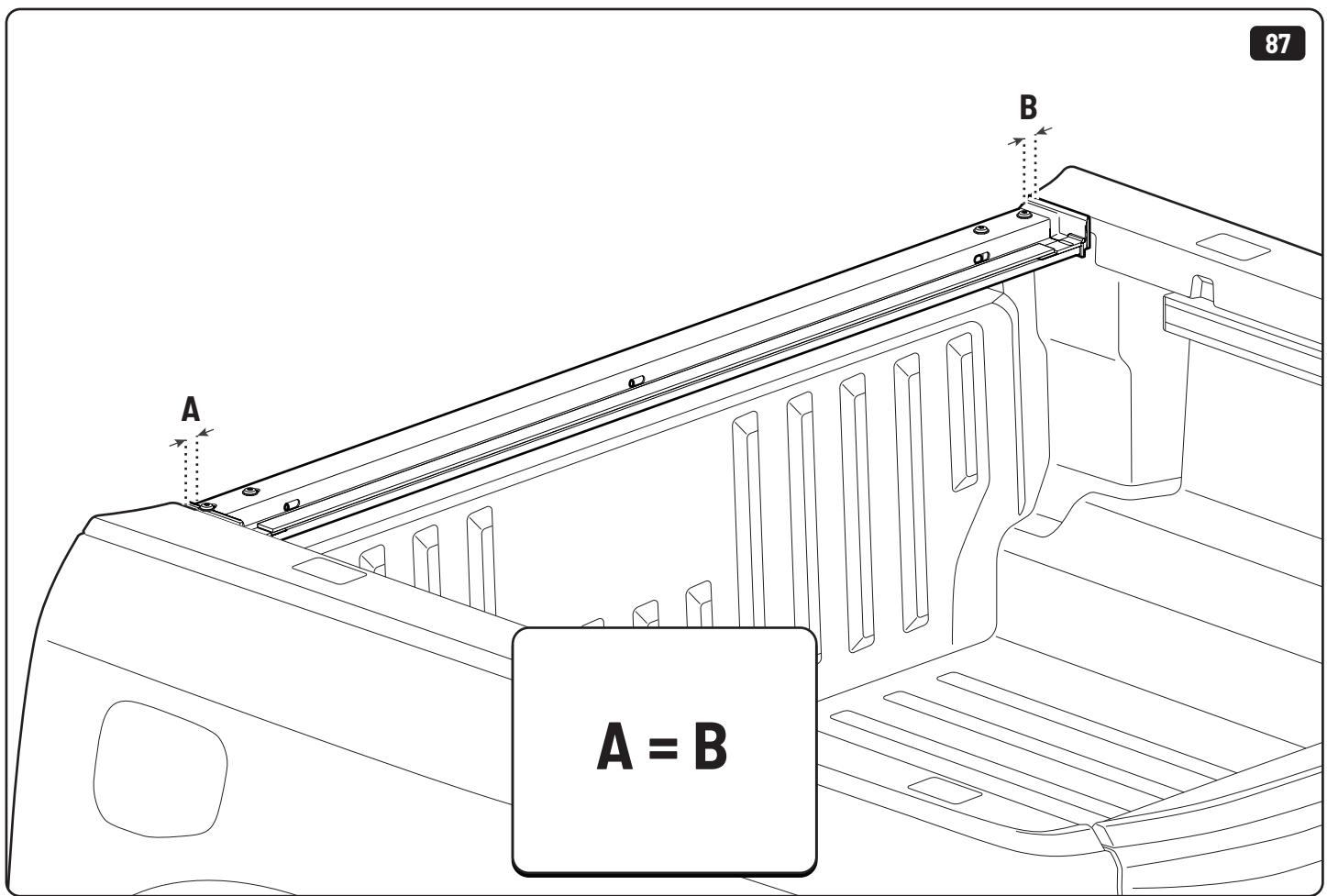

 **T45** **15 Nm**

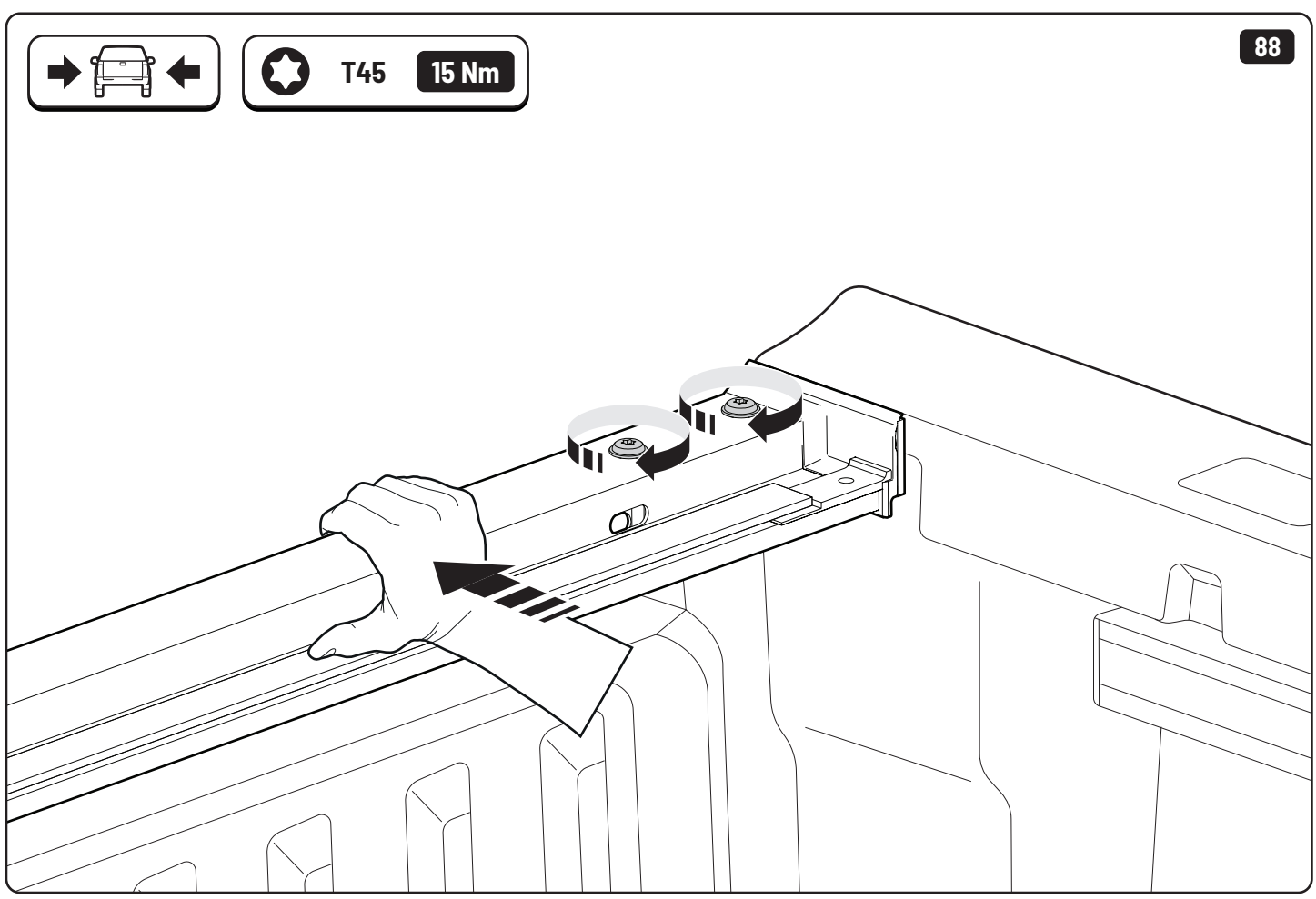

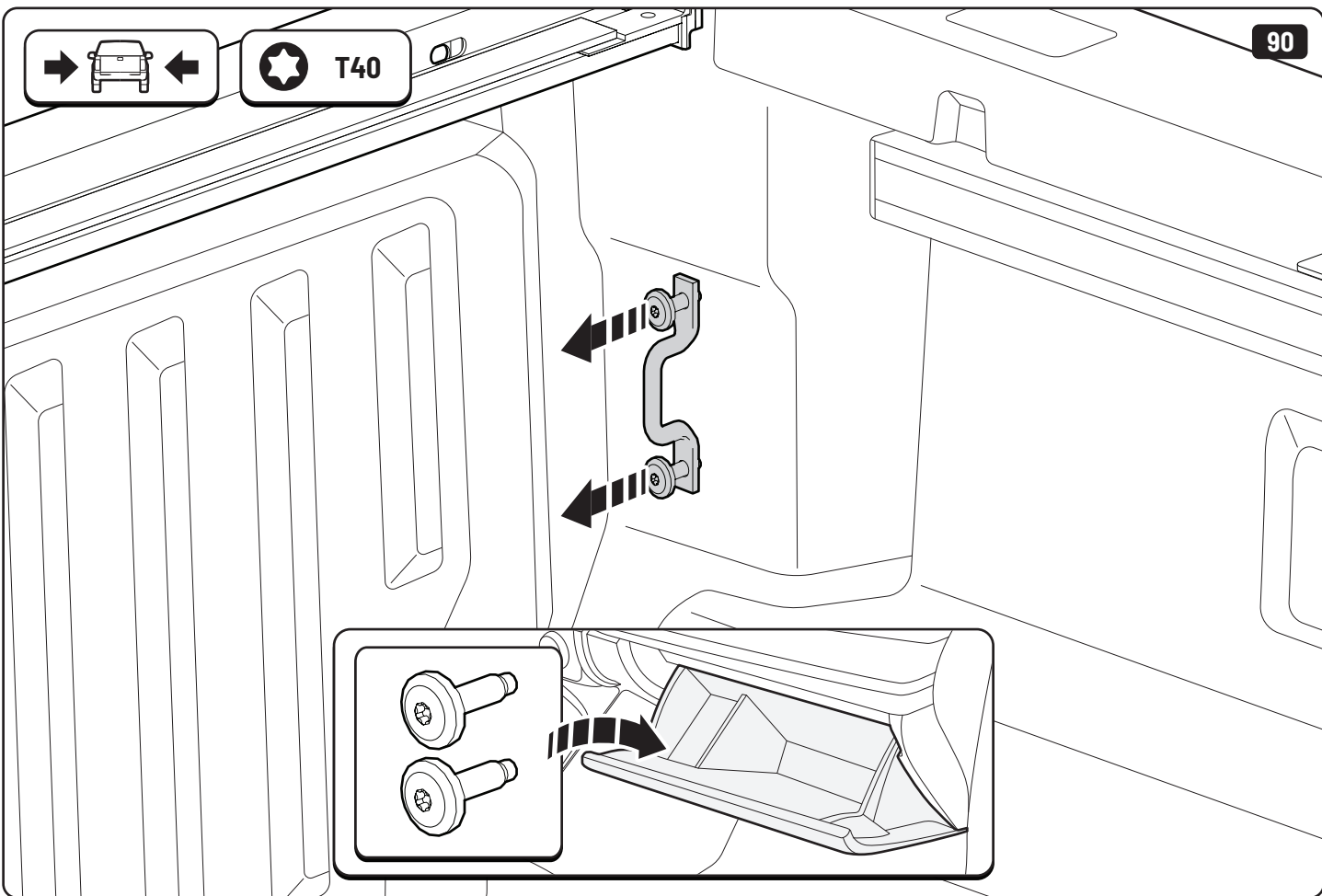
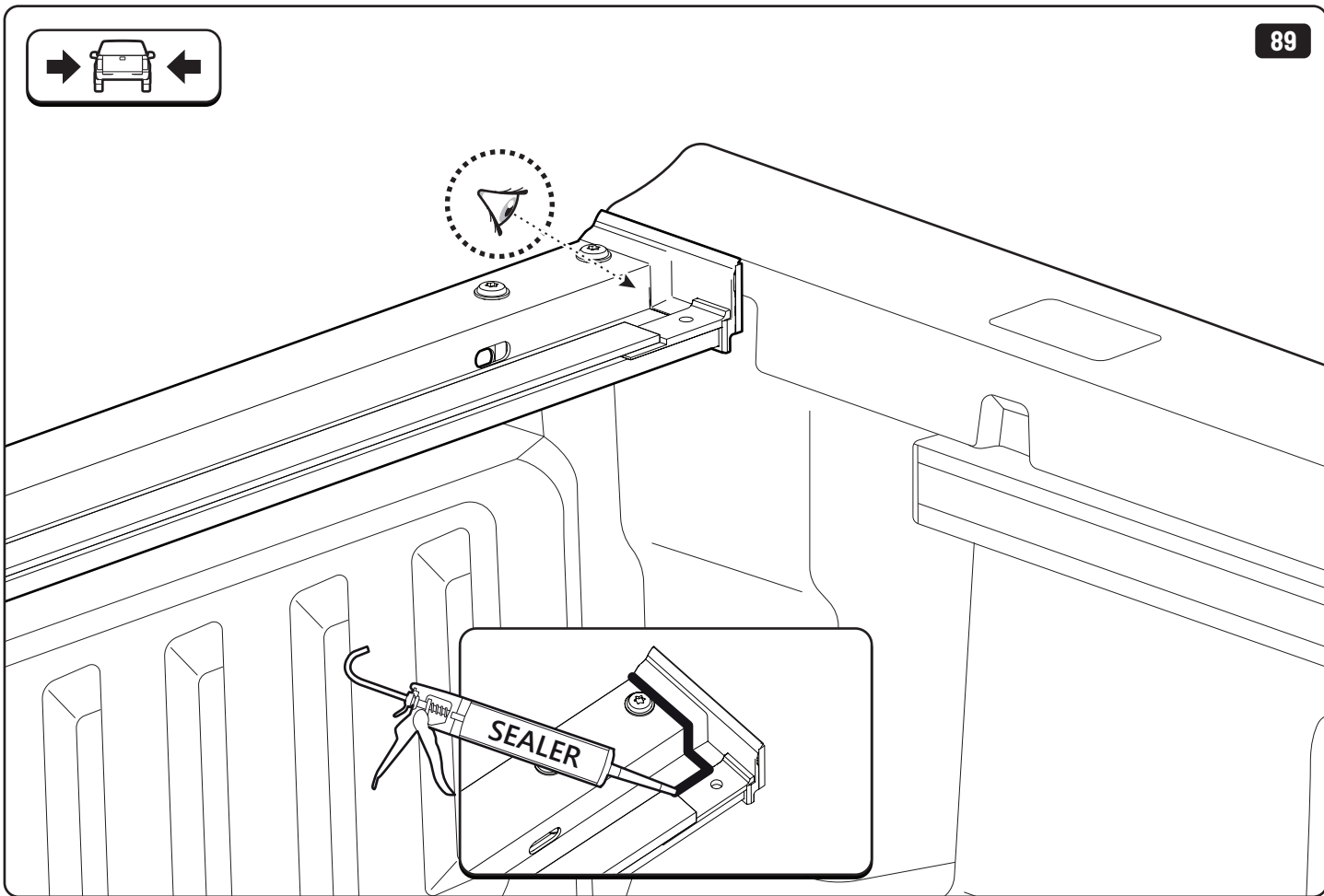

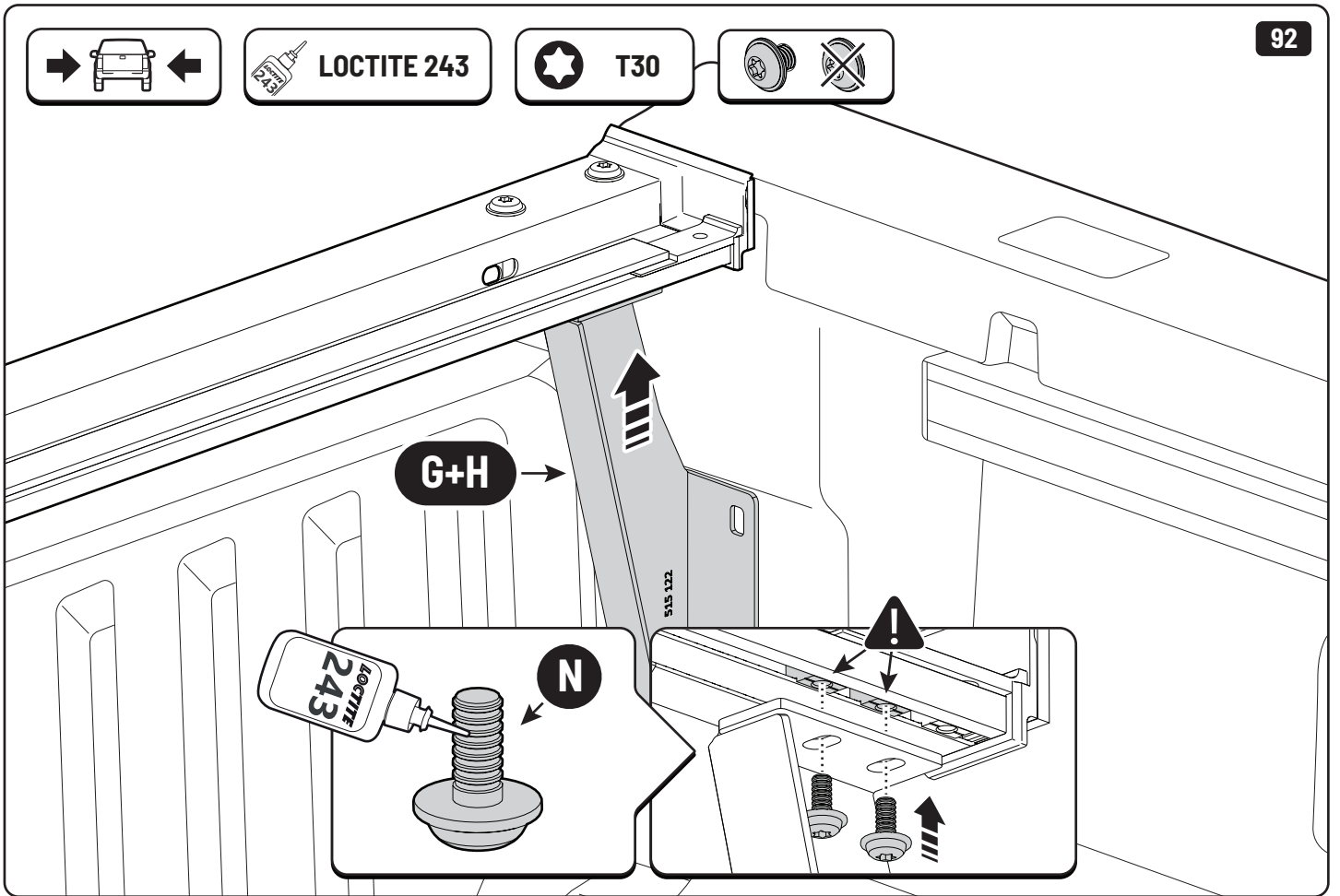
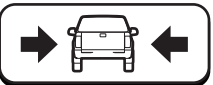
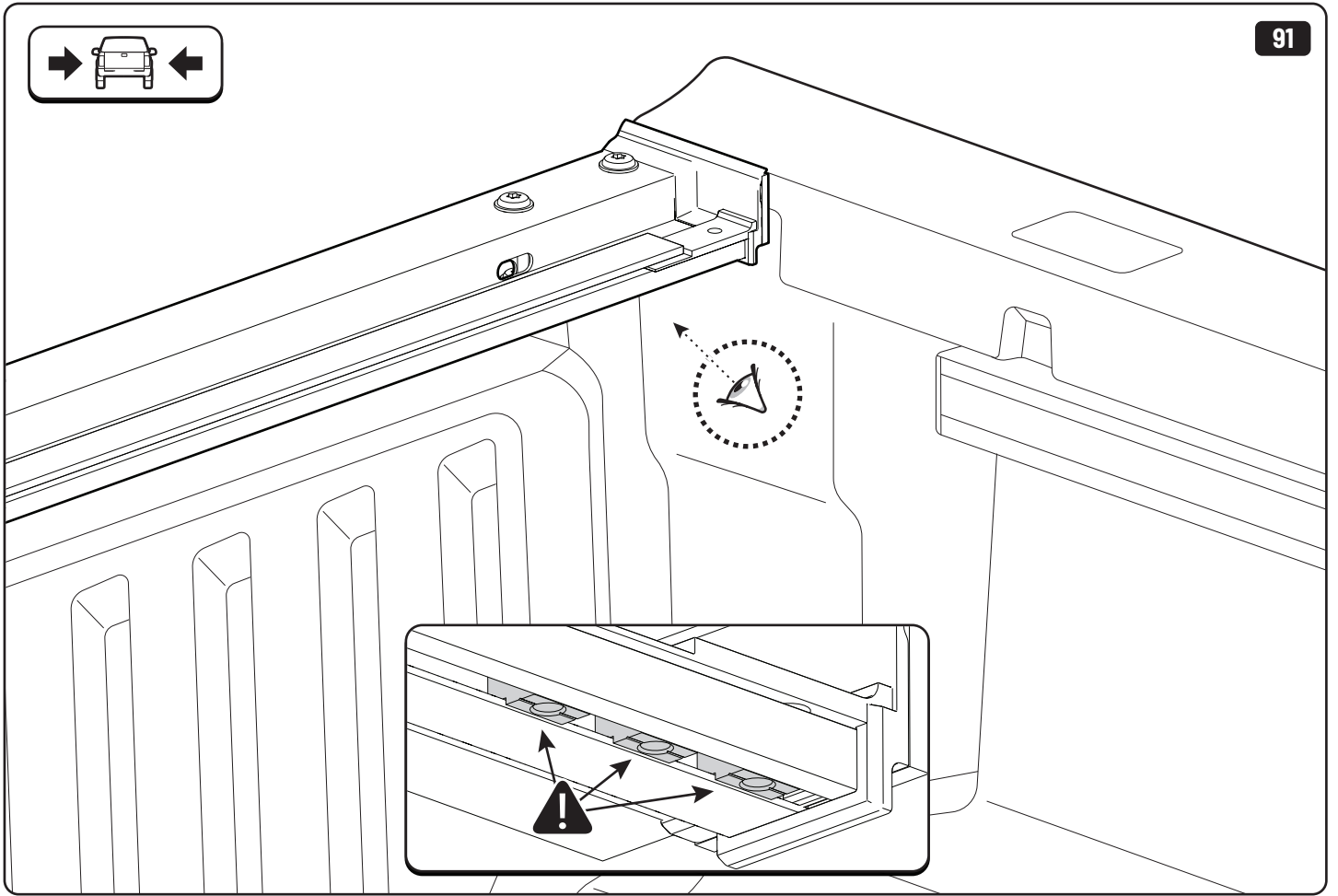
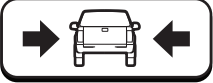

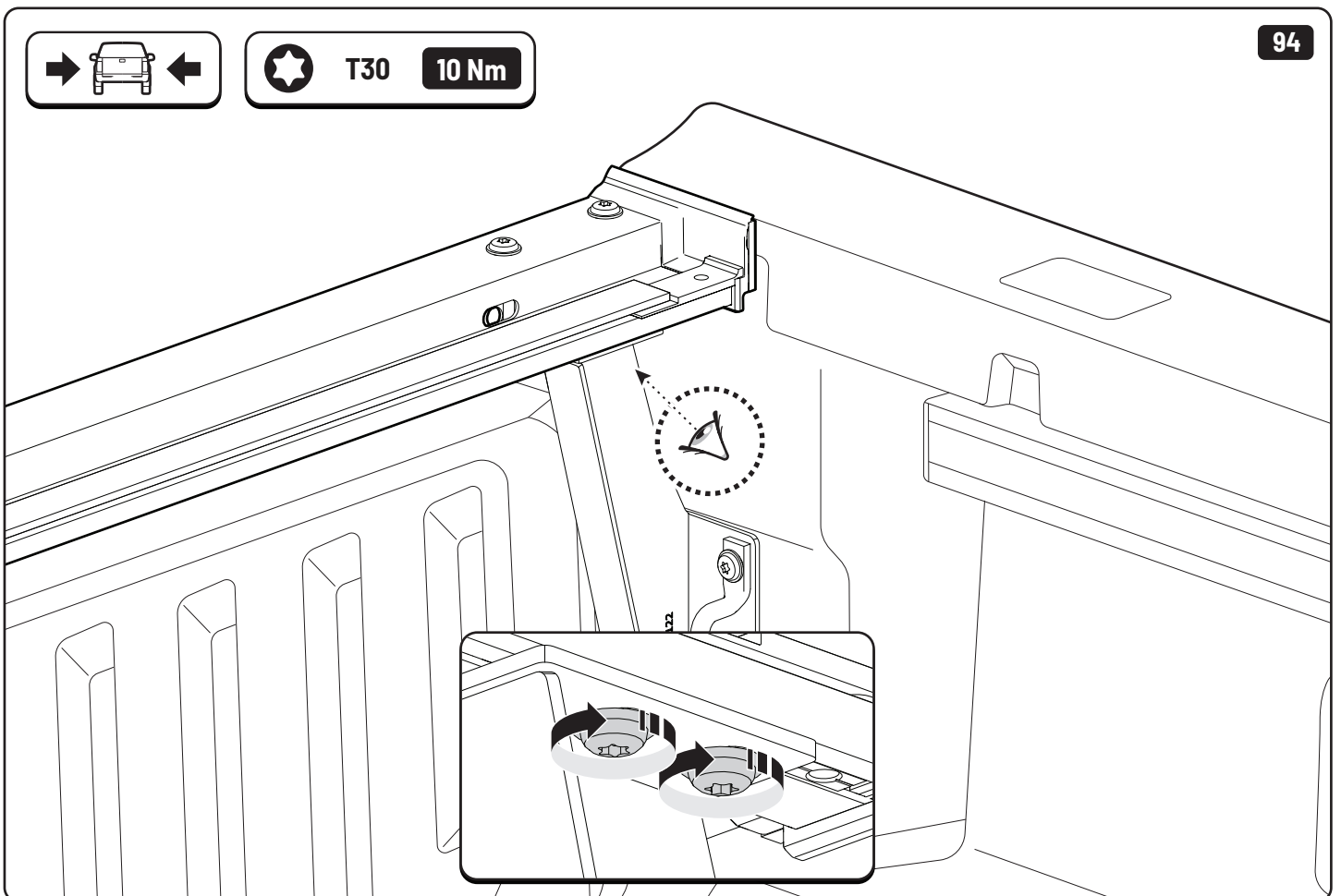
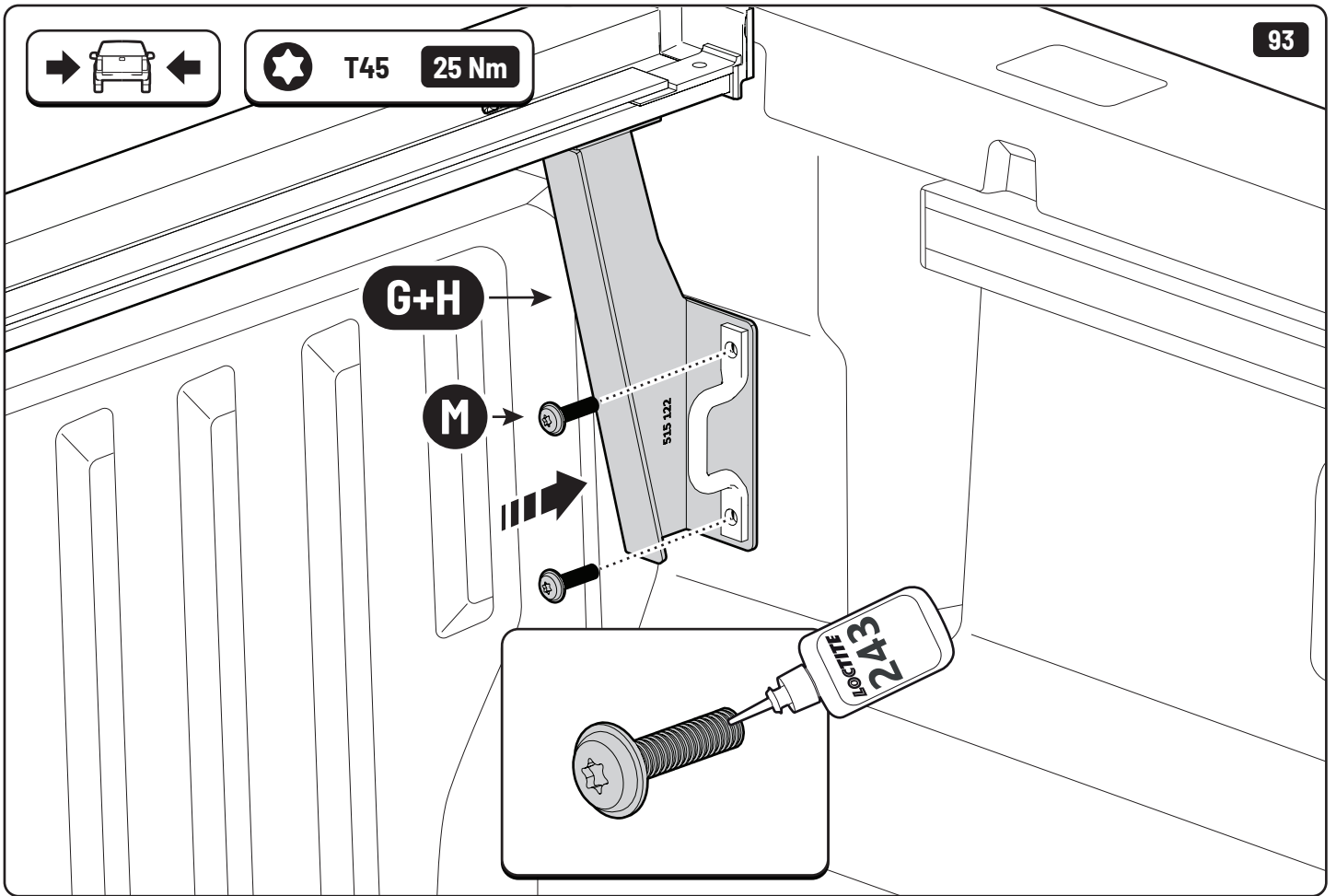

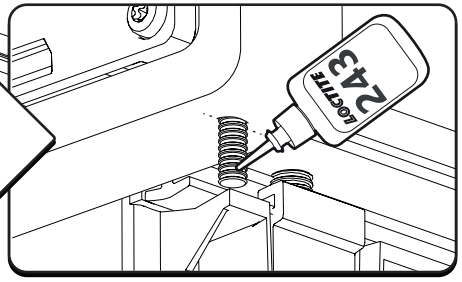
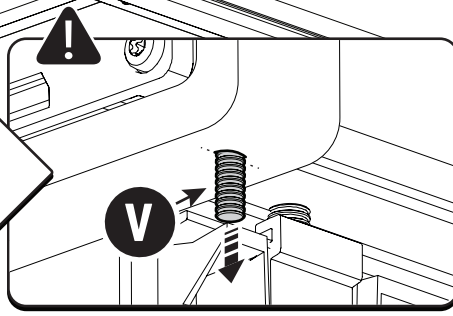
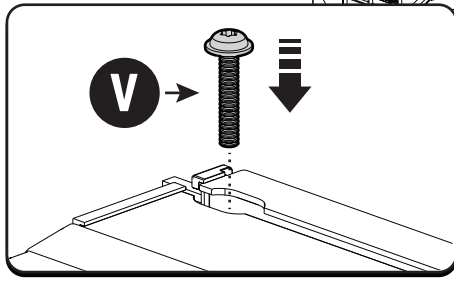
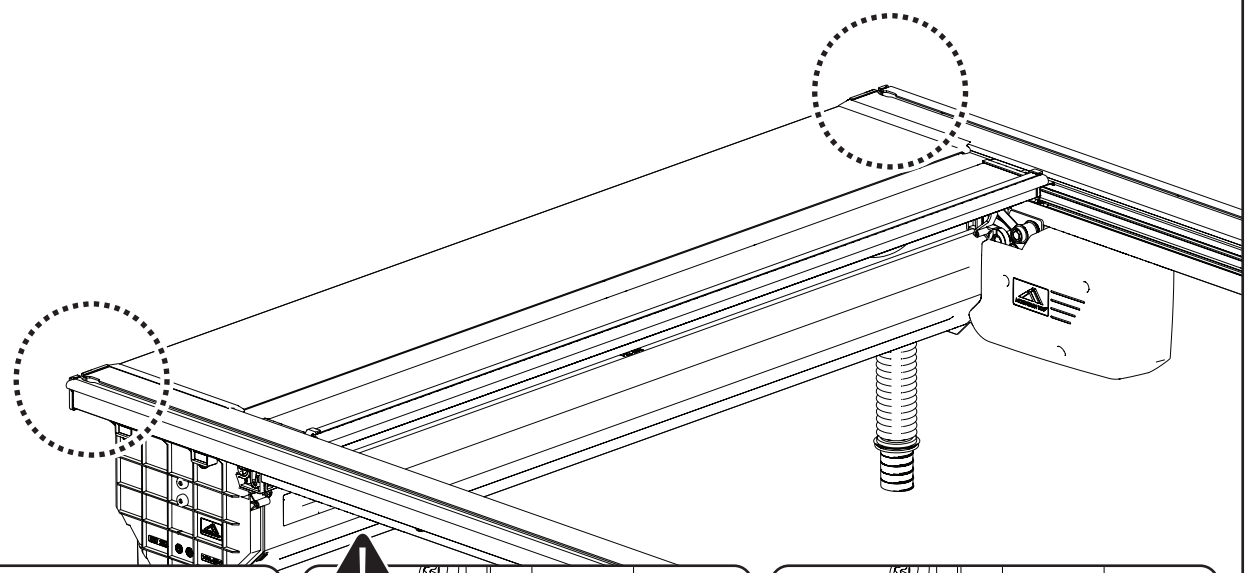
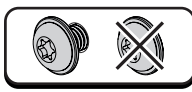
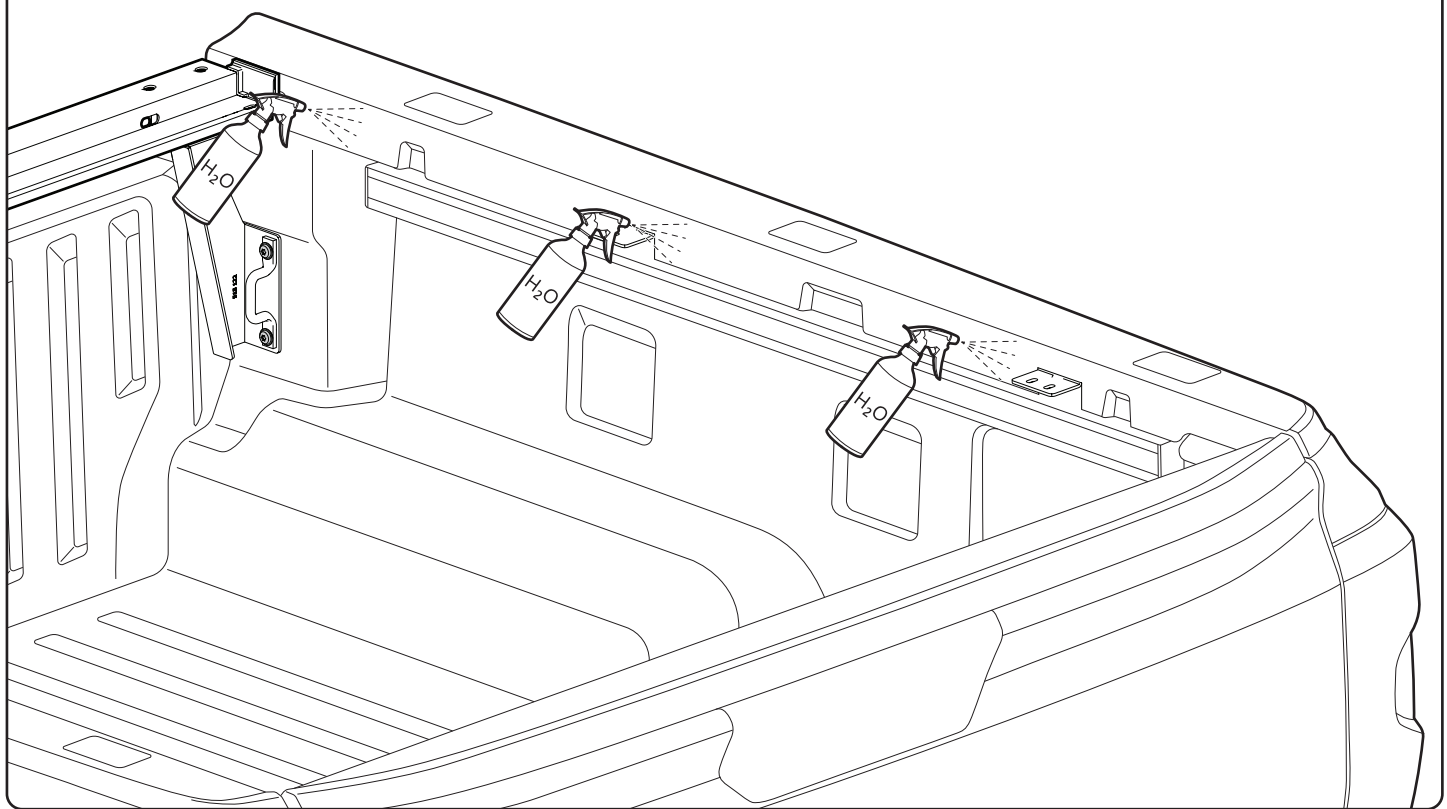

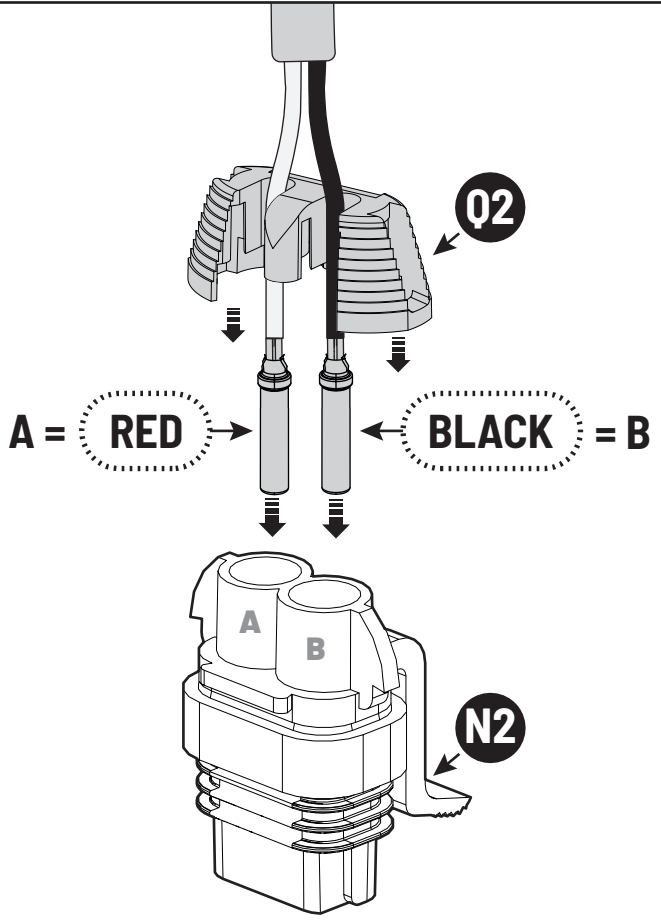
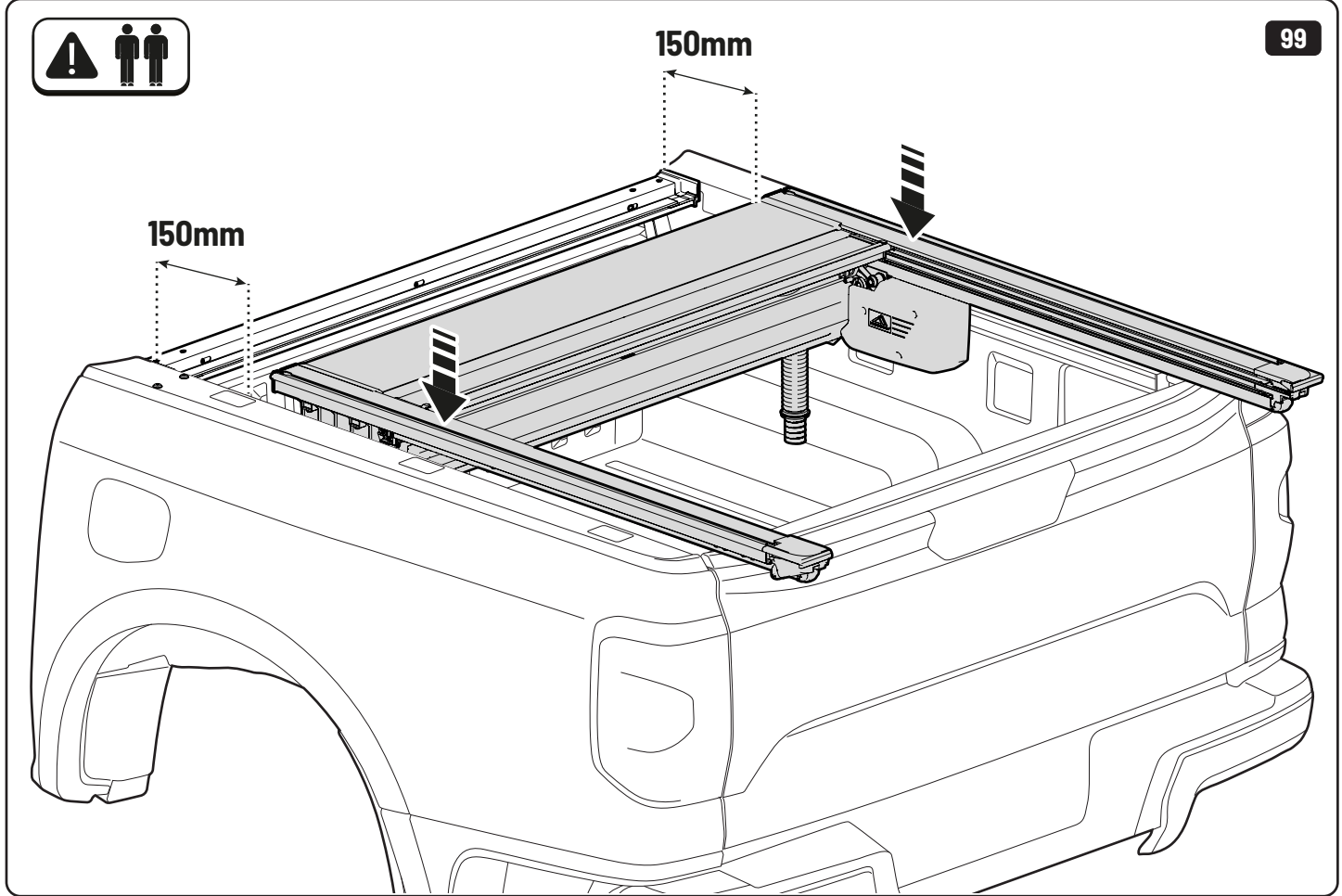

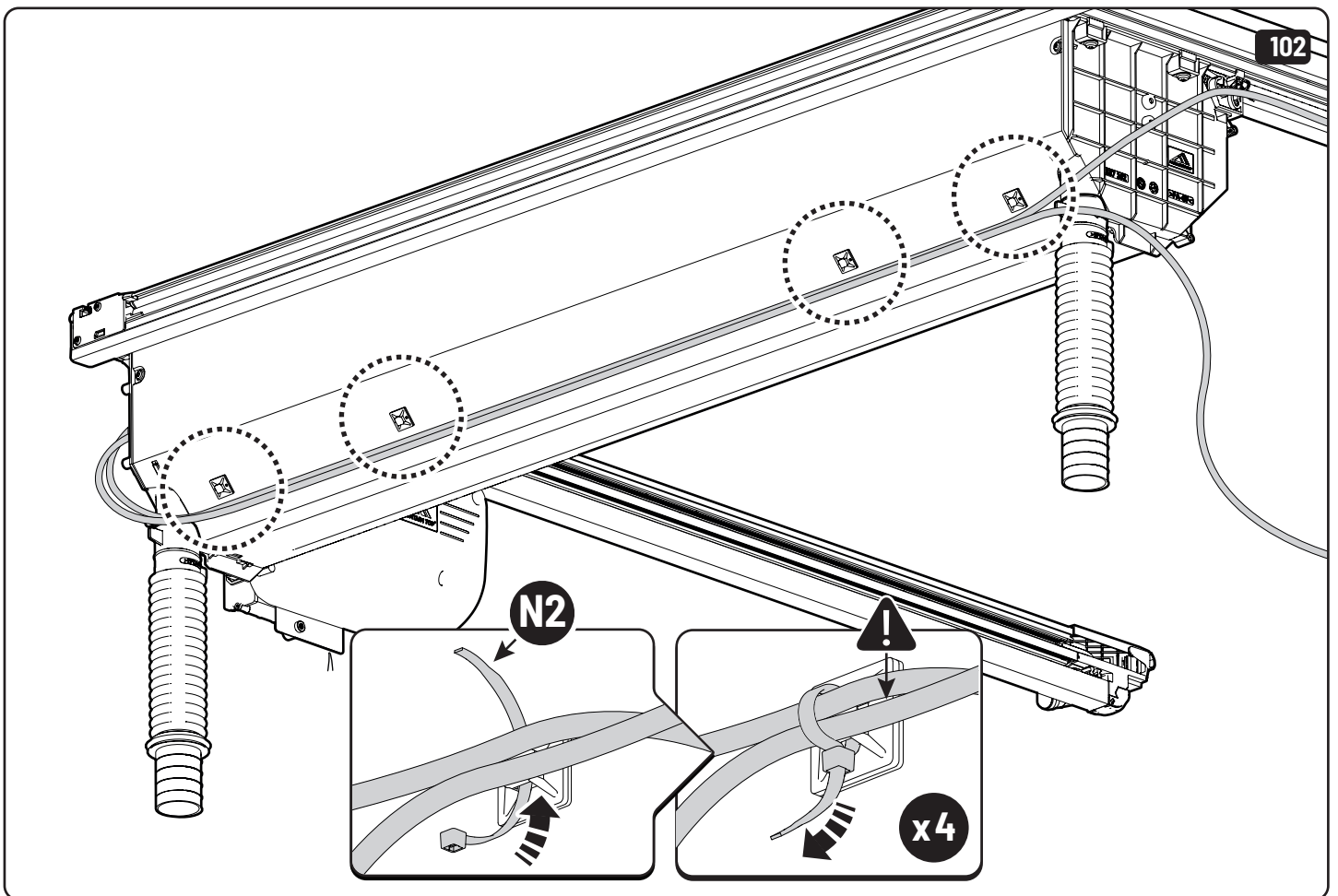
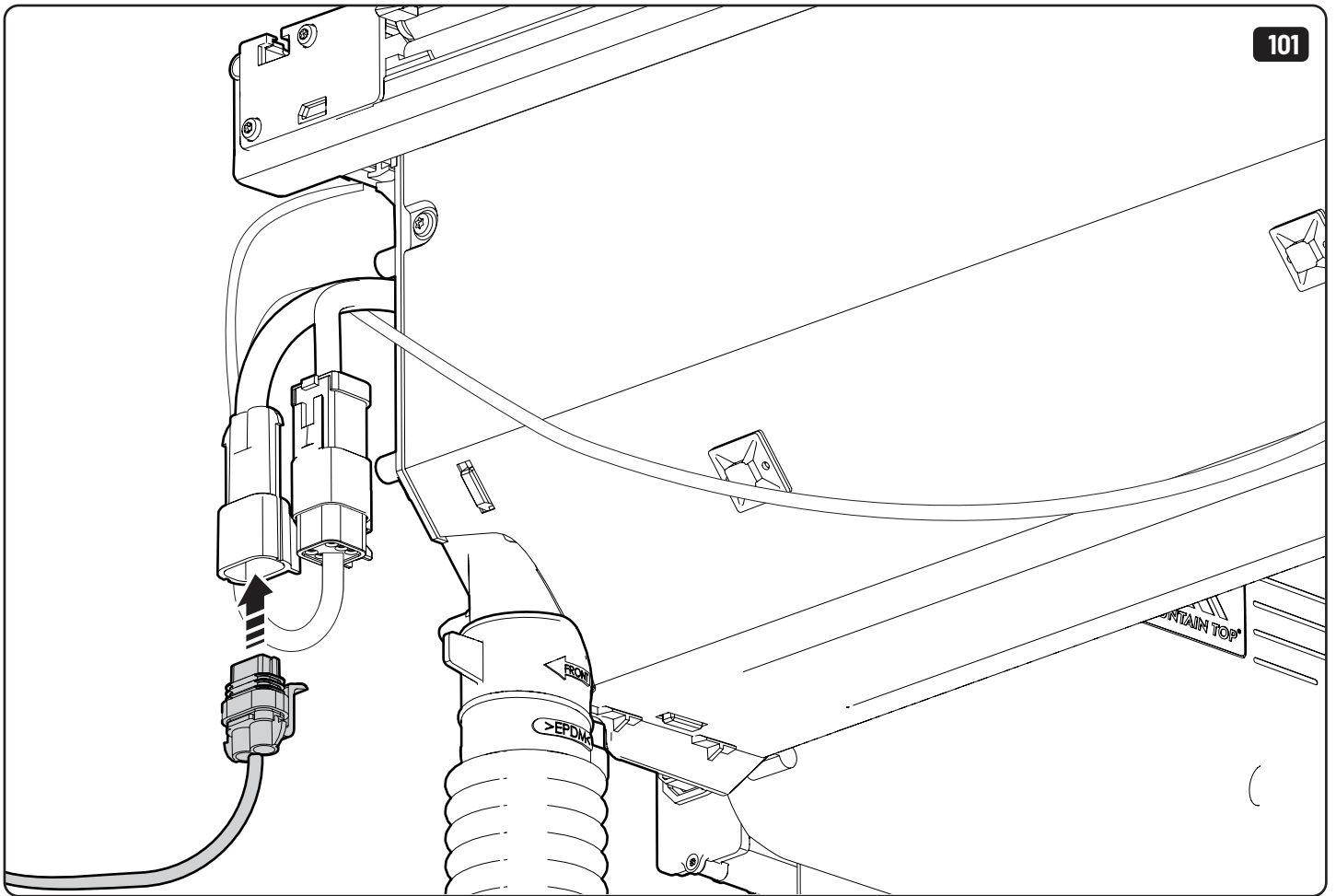

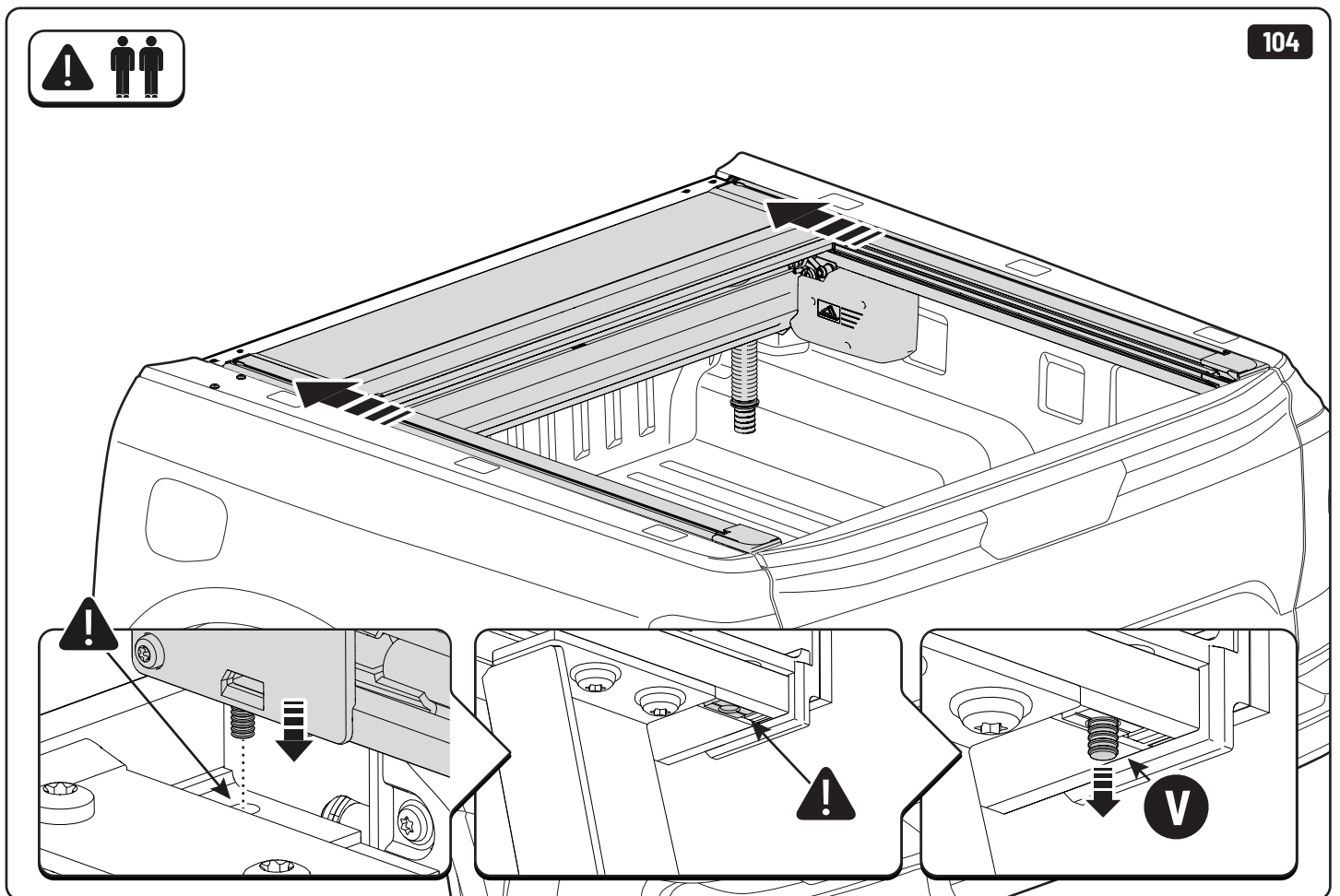
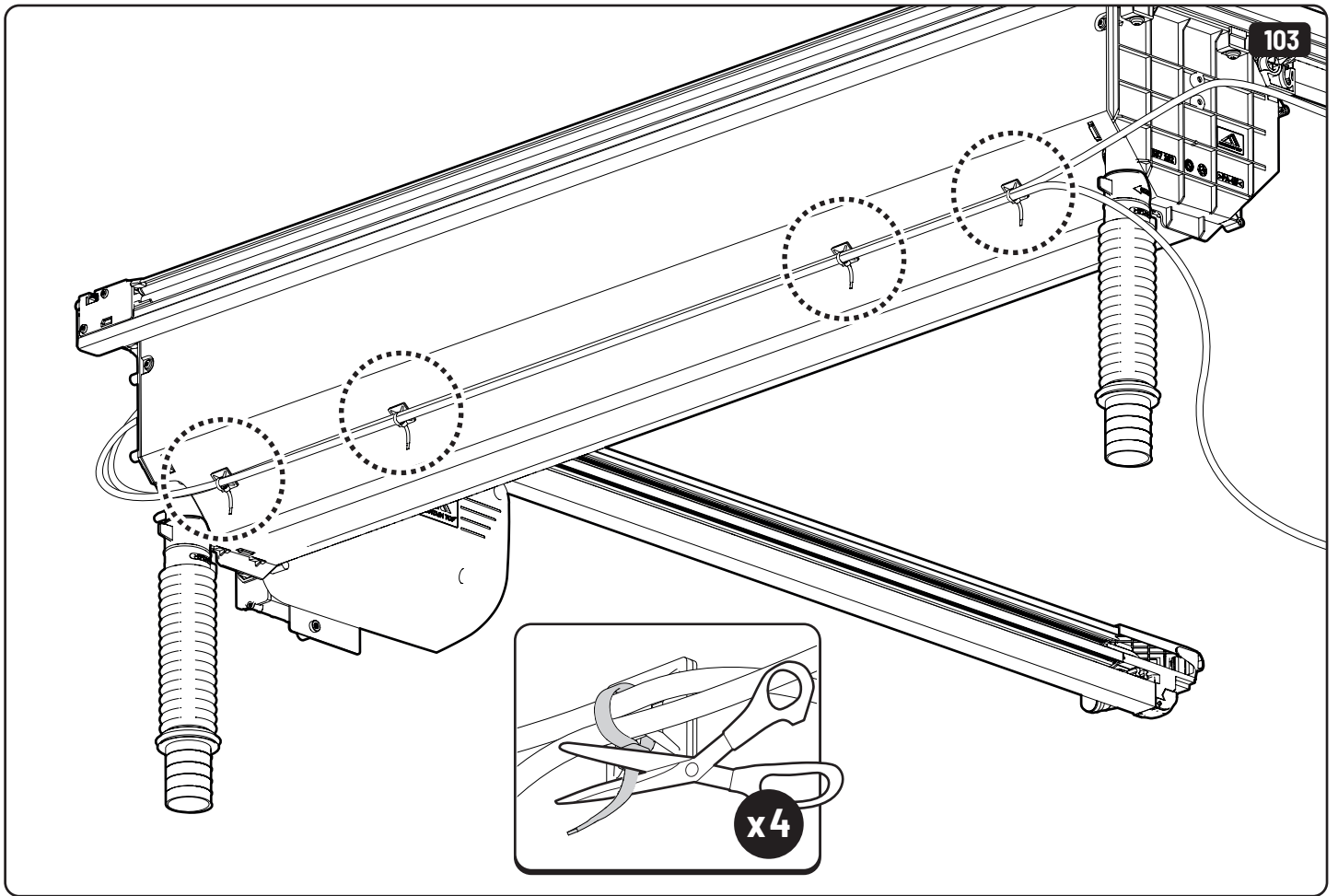

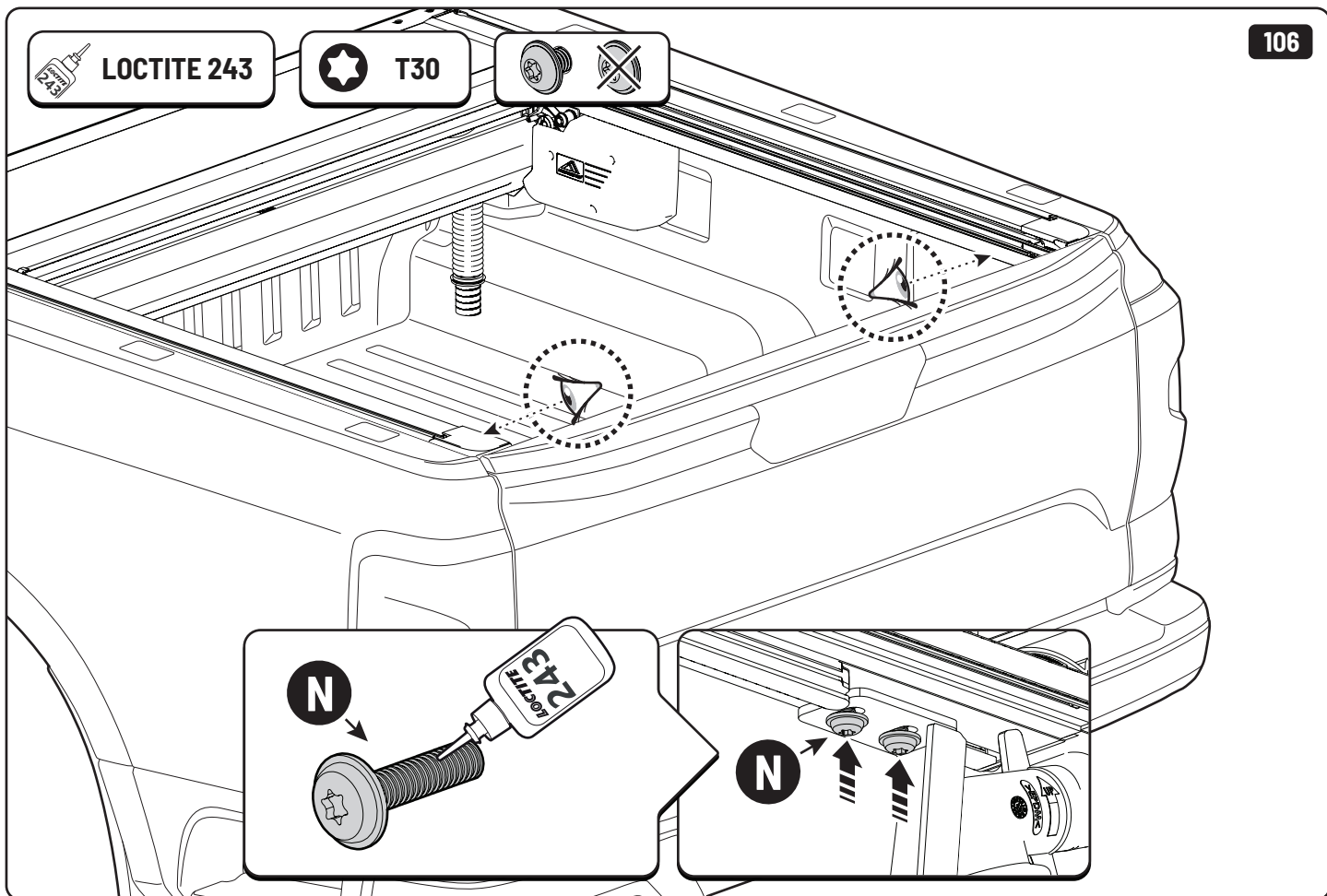
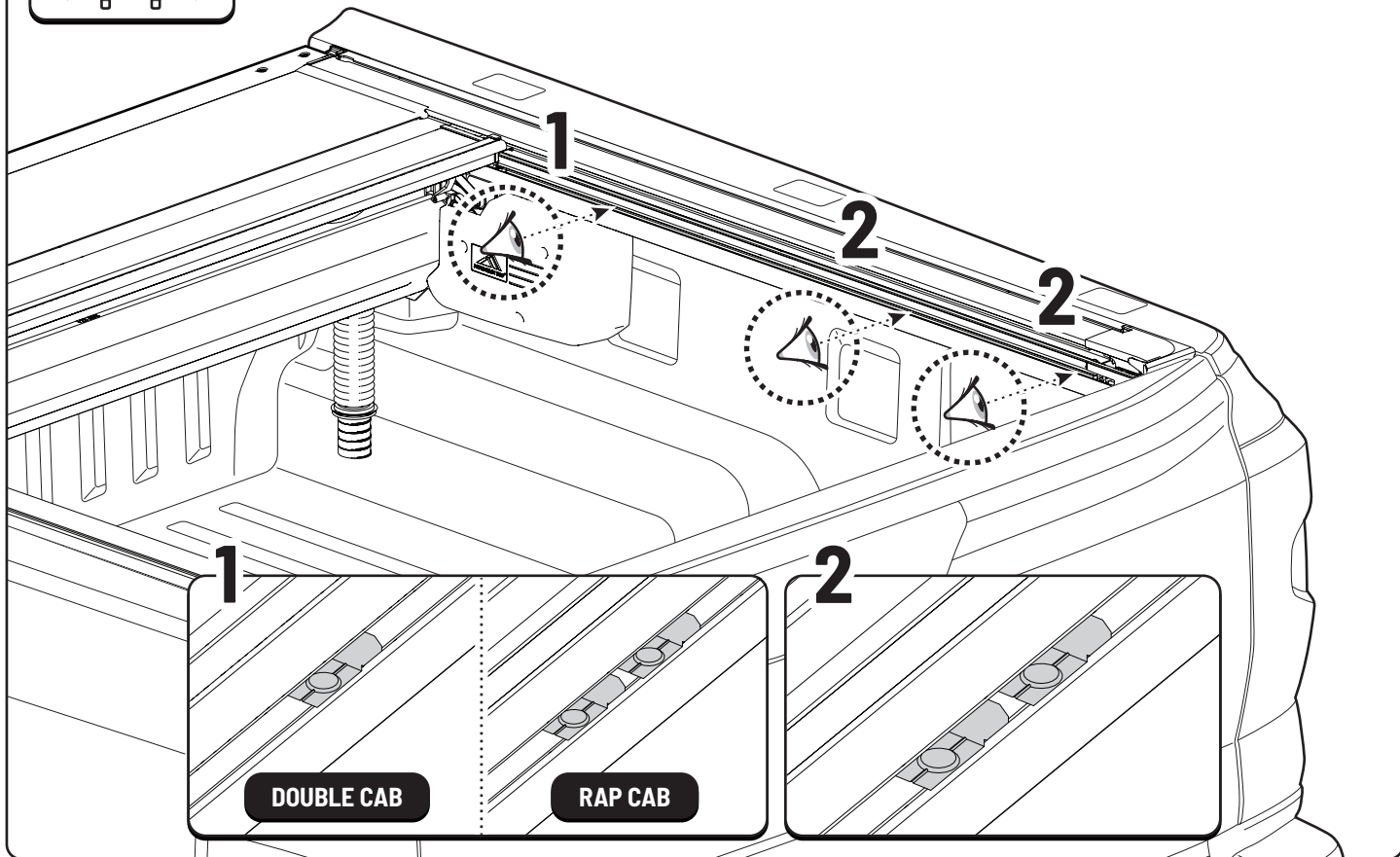

LOCTITE 243

T30



107

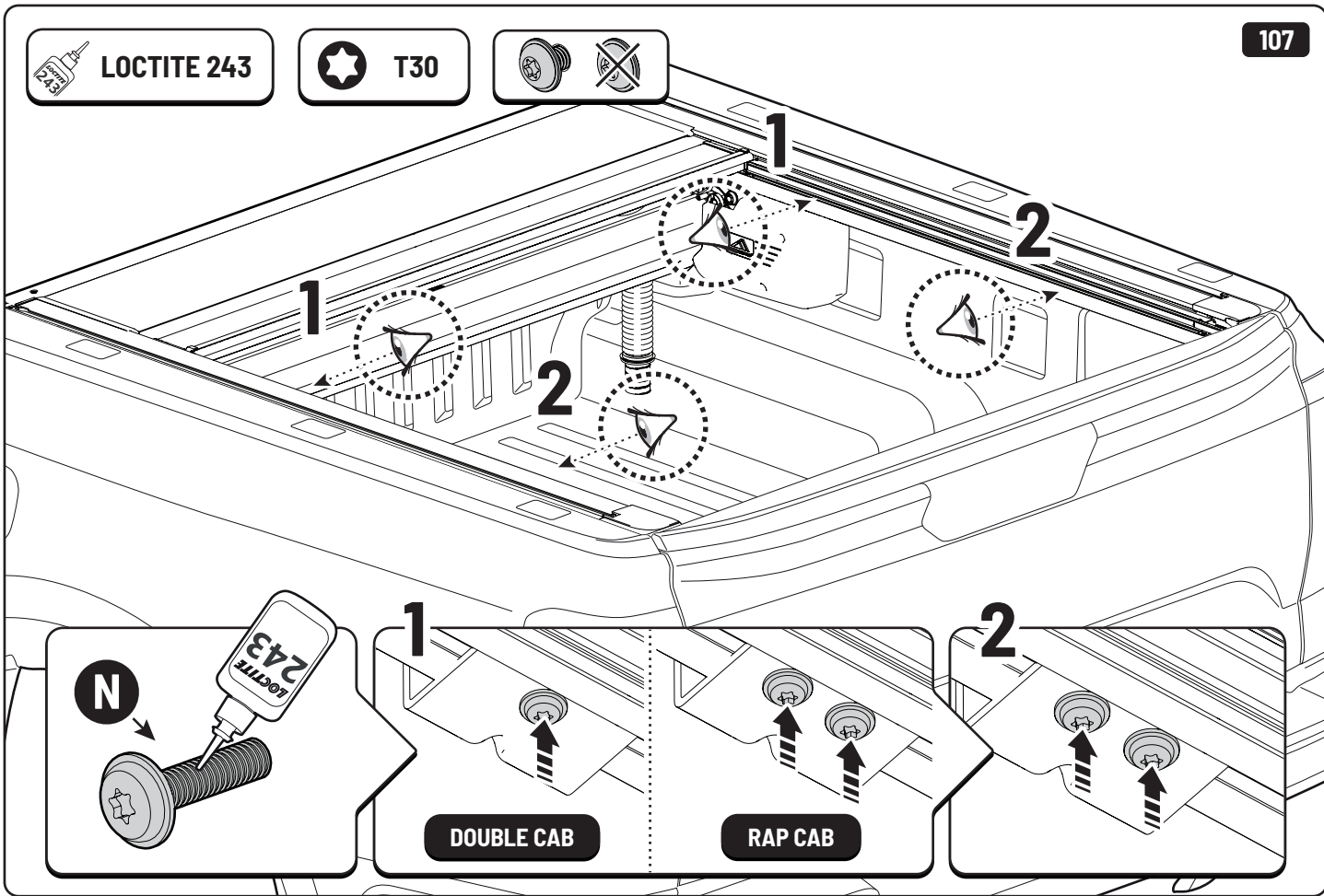

! ONLY FOR FORD RAPTOR / WILDTRAK



108

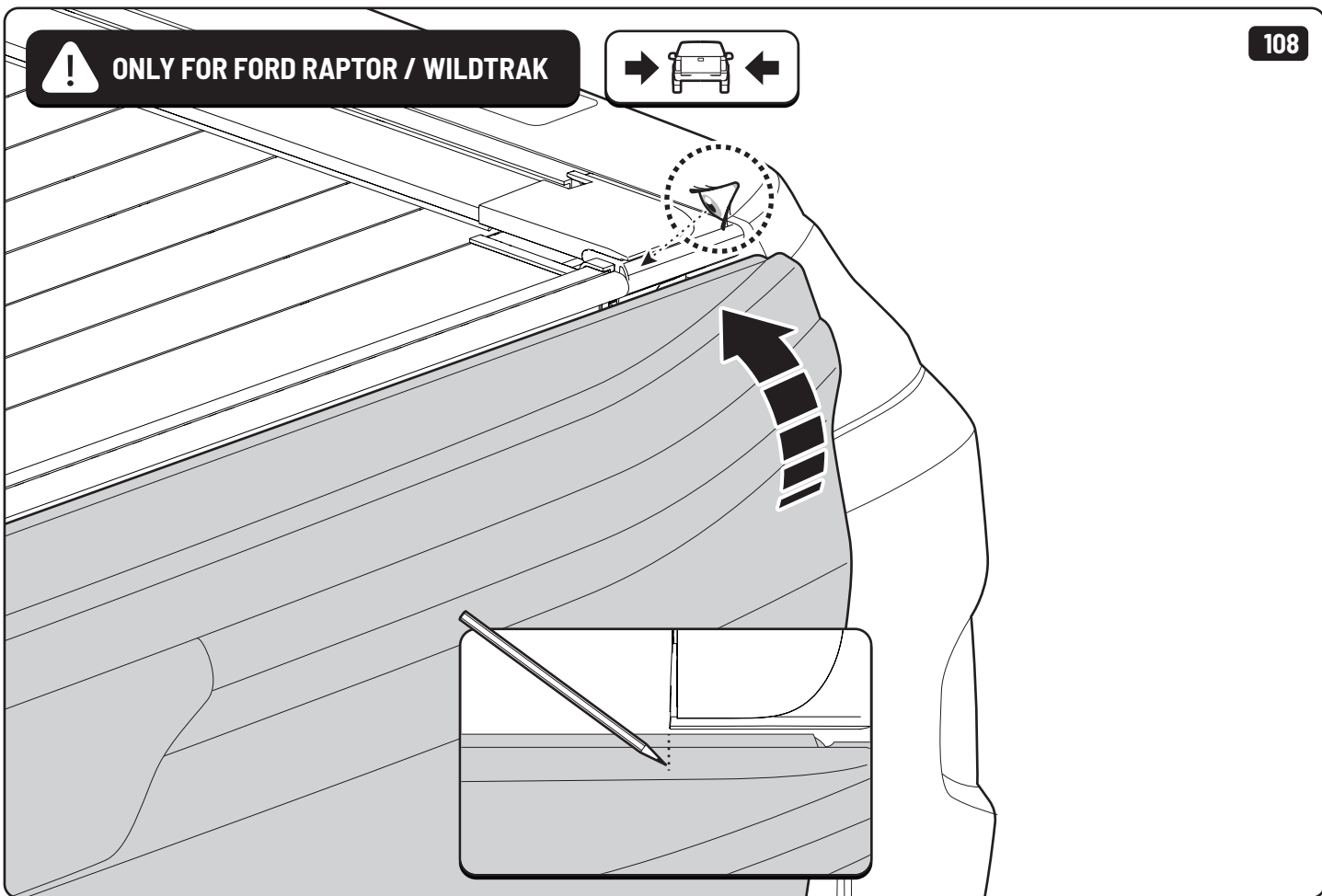

! ONLY FOR FORD RAPTOR / WILDTRAK



109

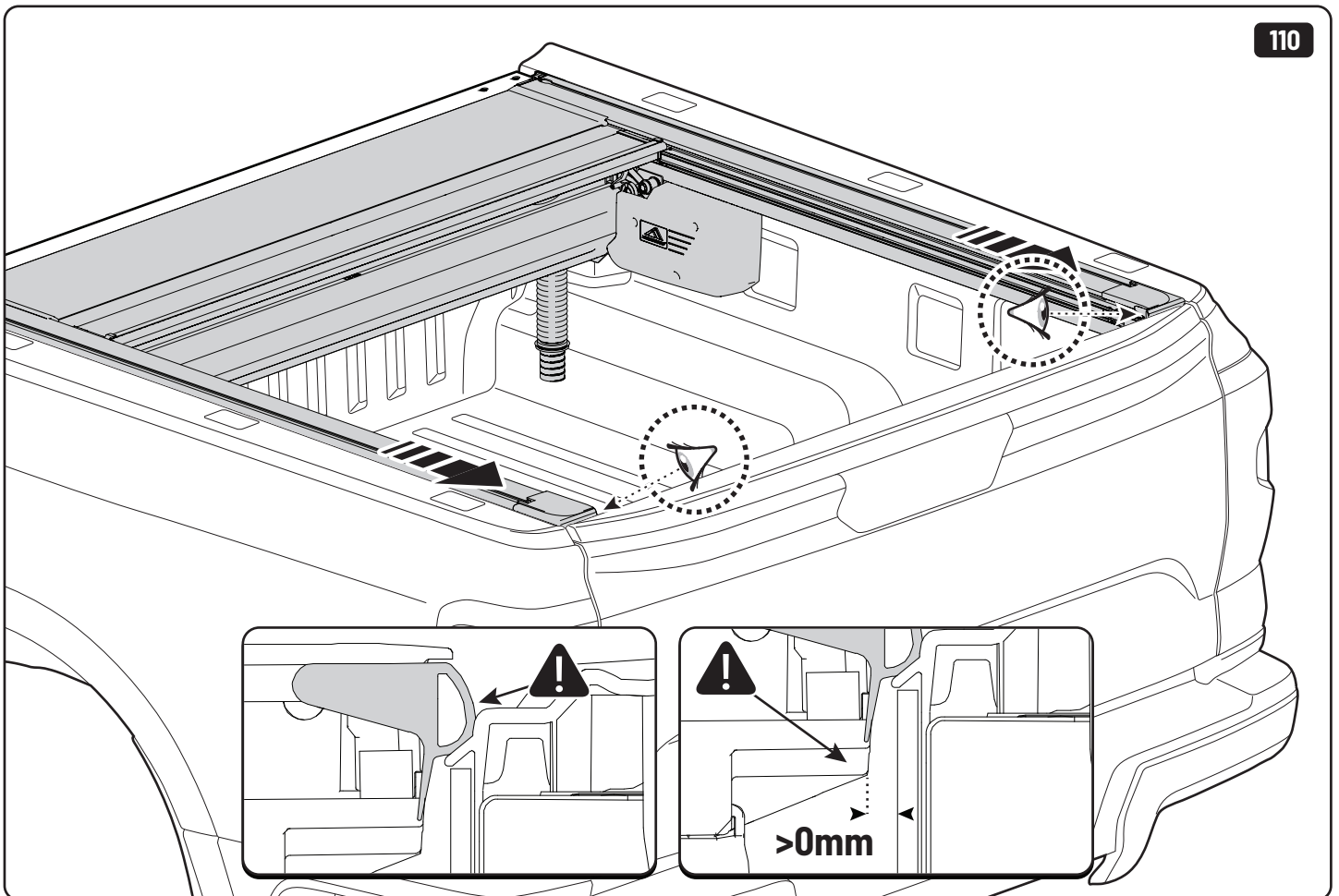
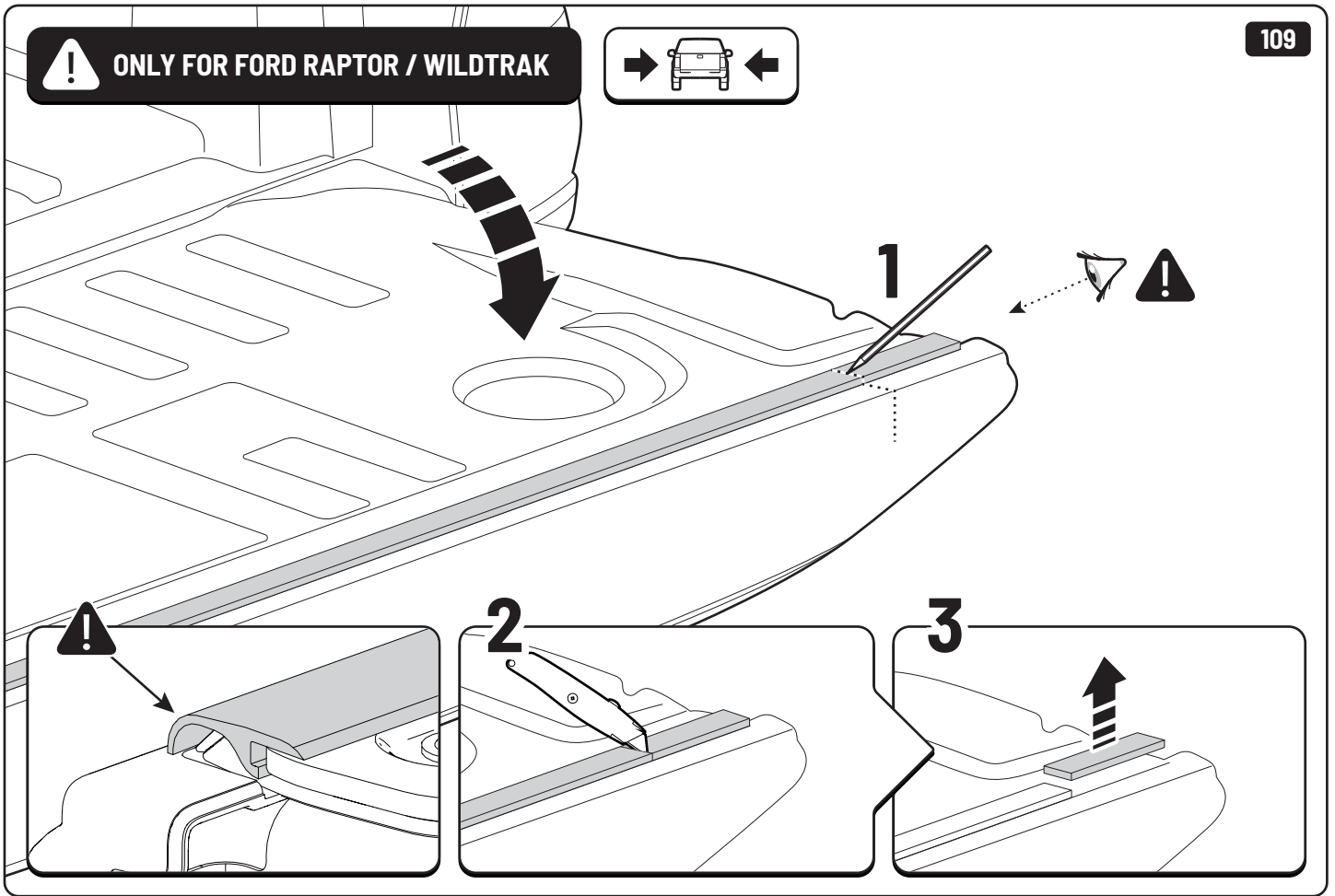

110

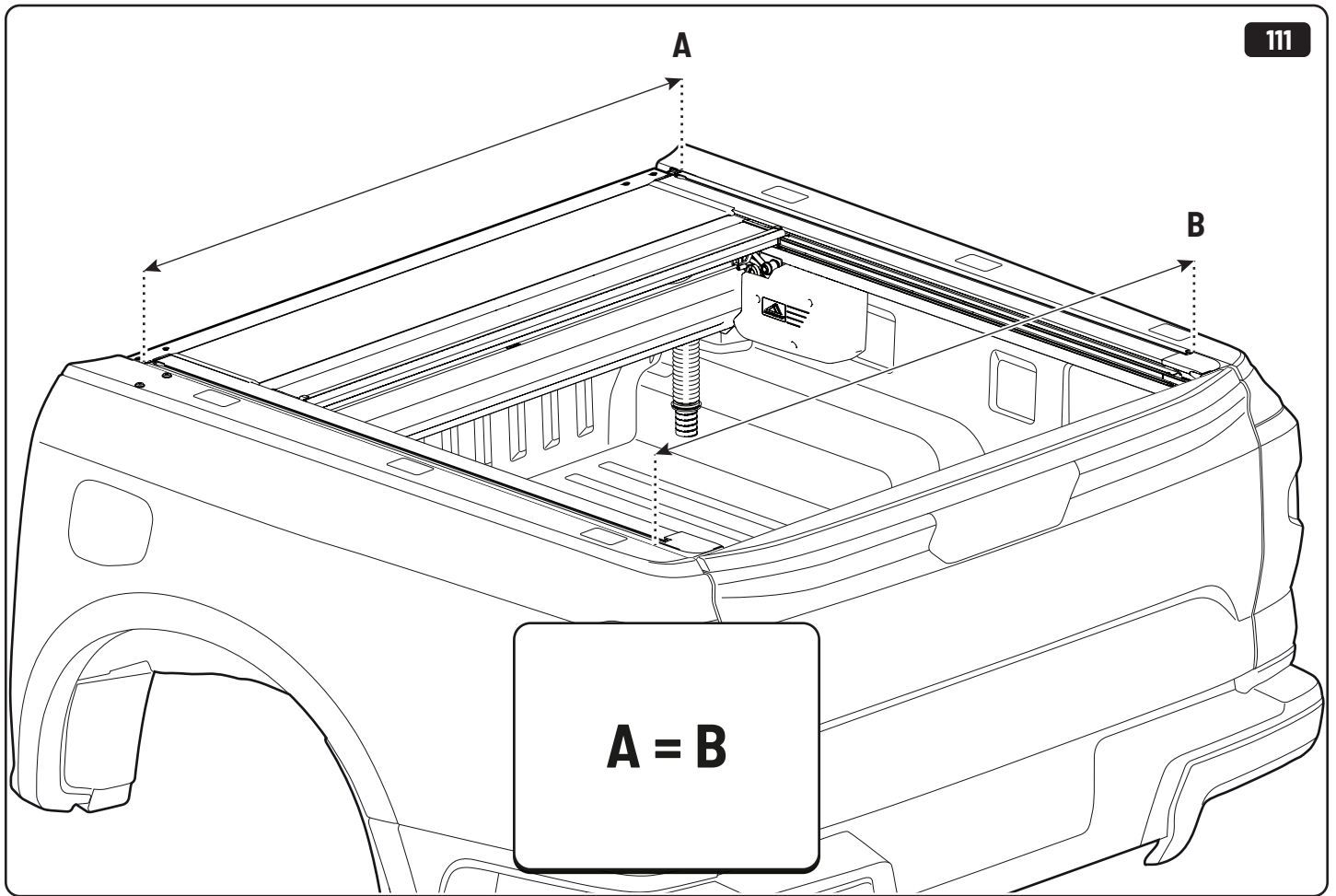

 T30 10 Nm

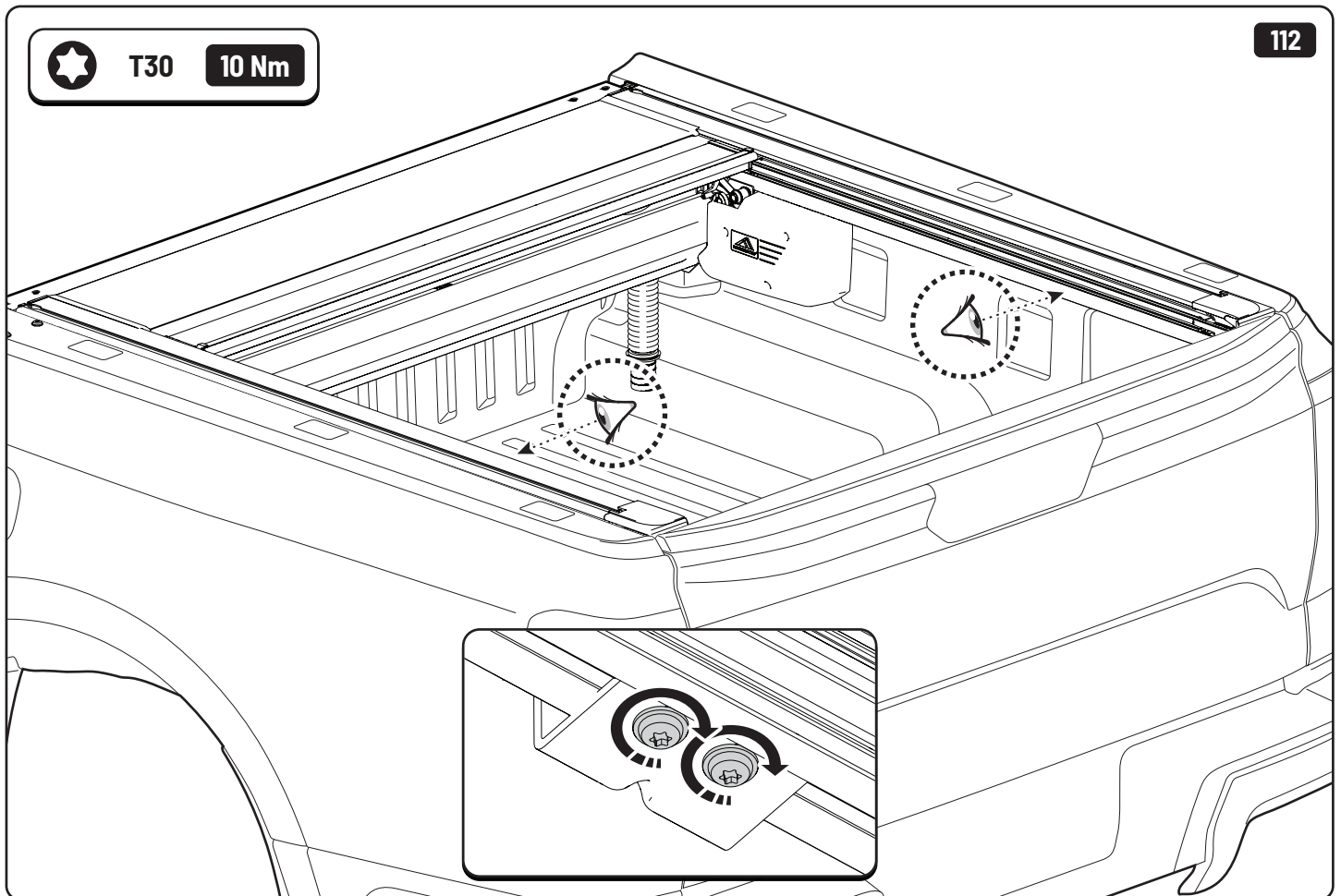

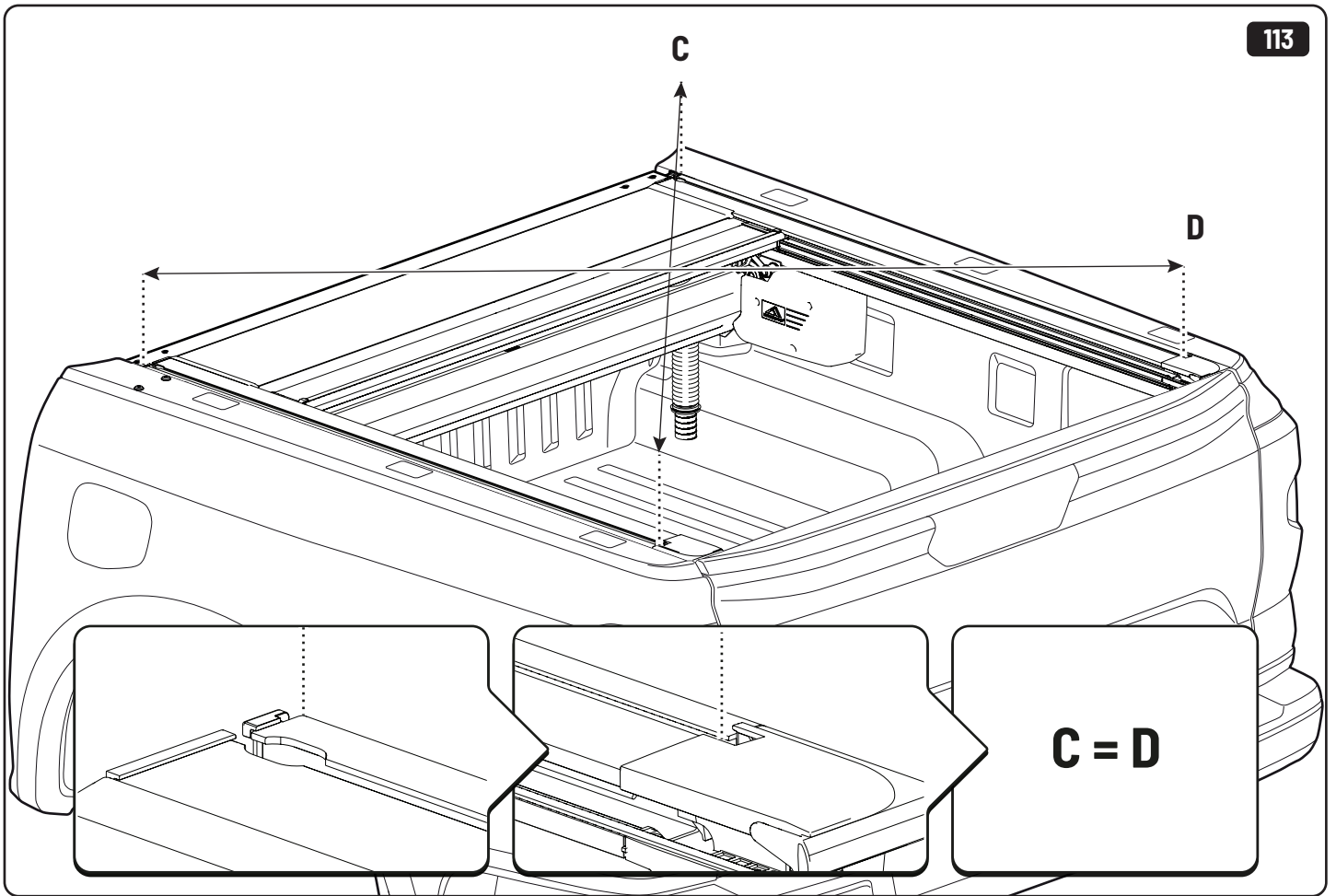

T30

4,8 Nm

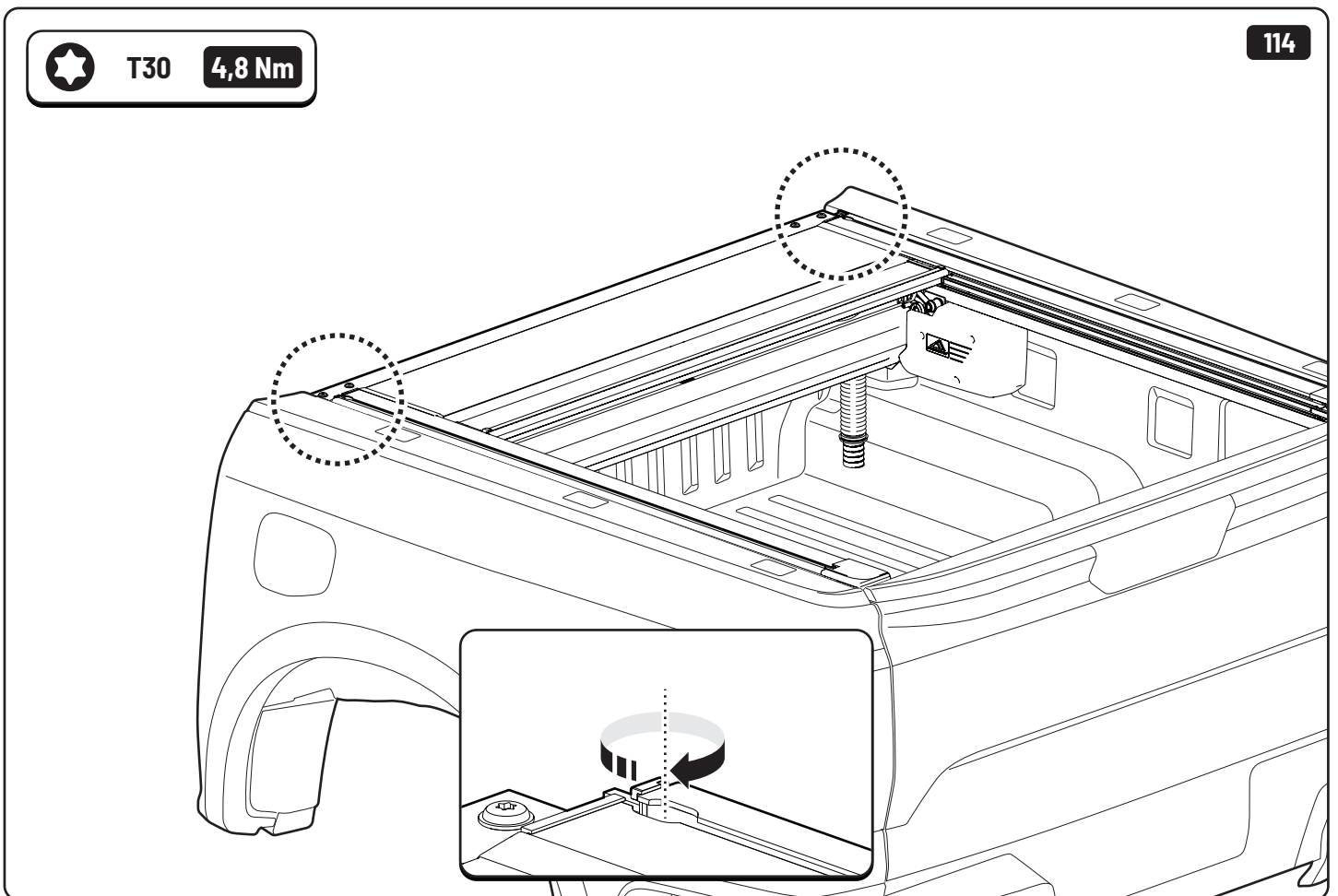

 T30 10 Nm

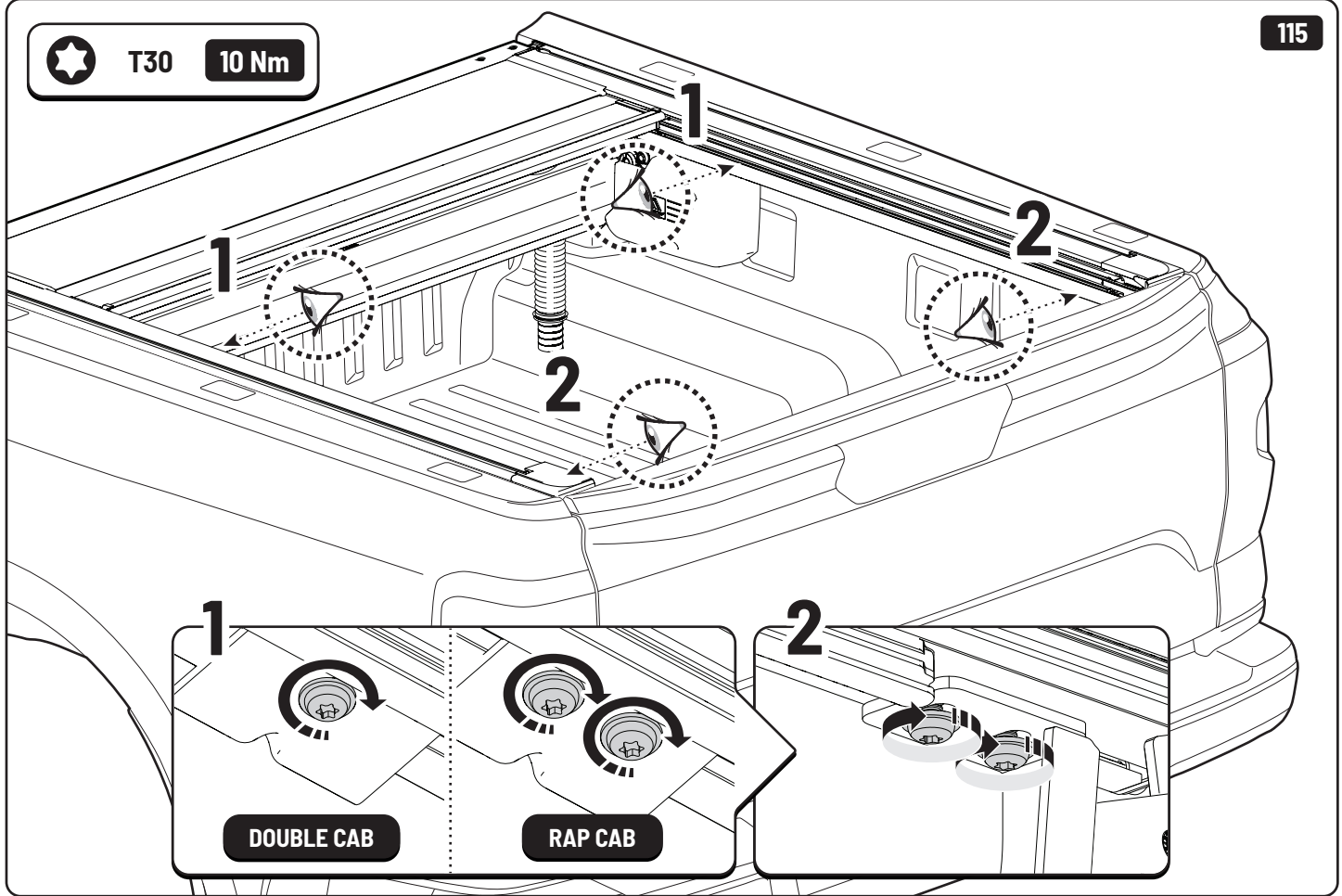

 T45 25 Nm

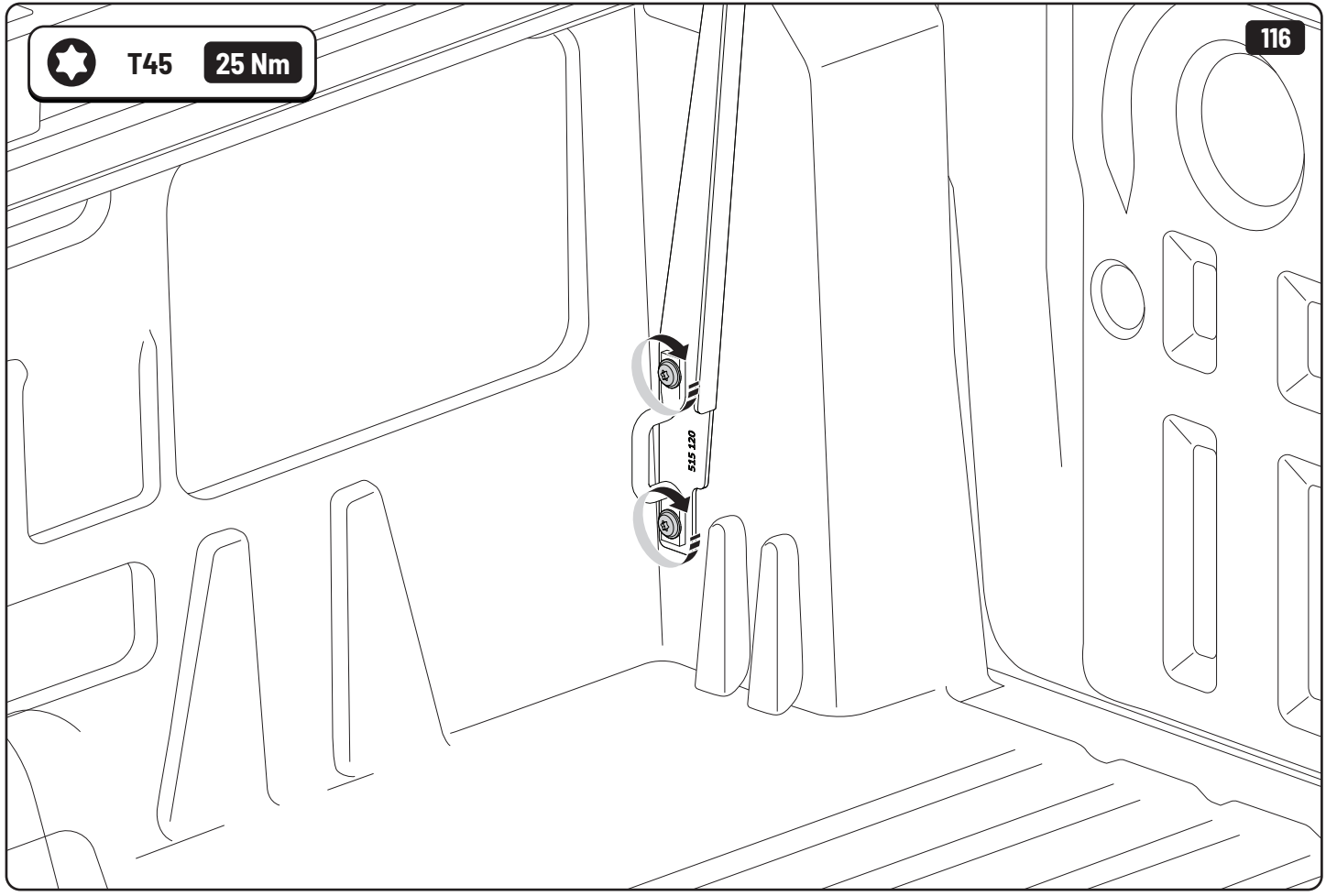

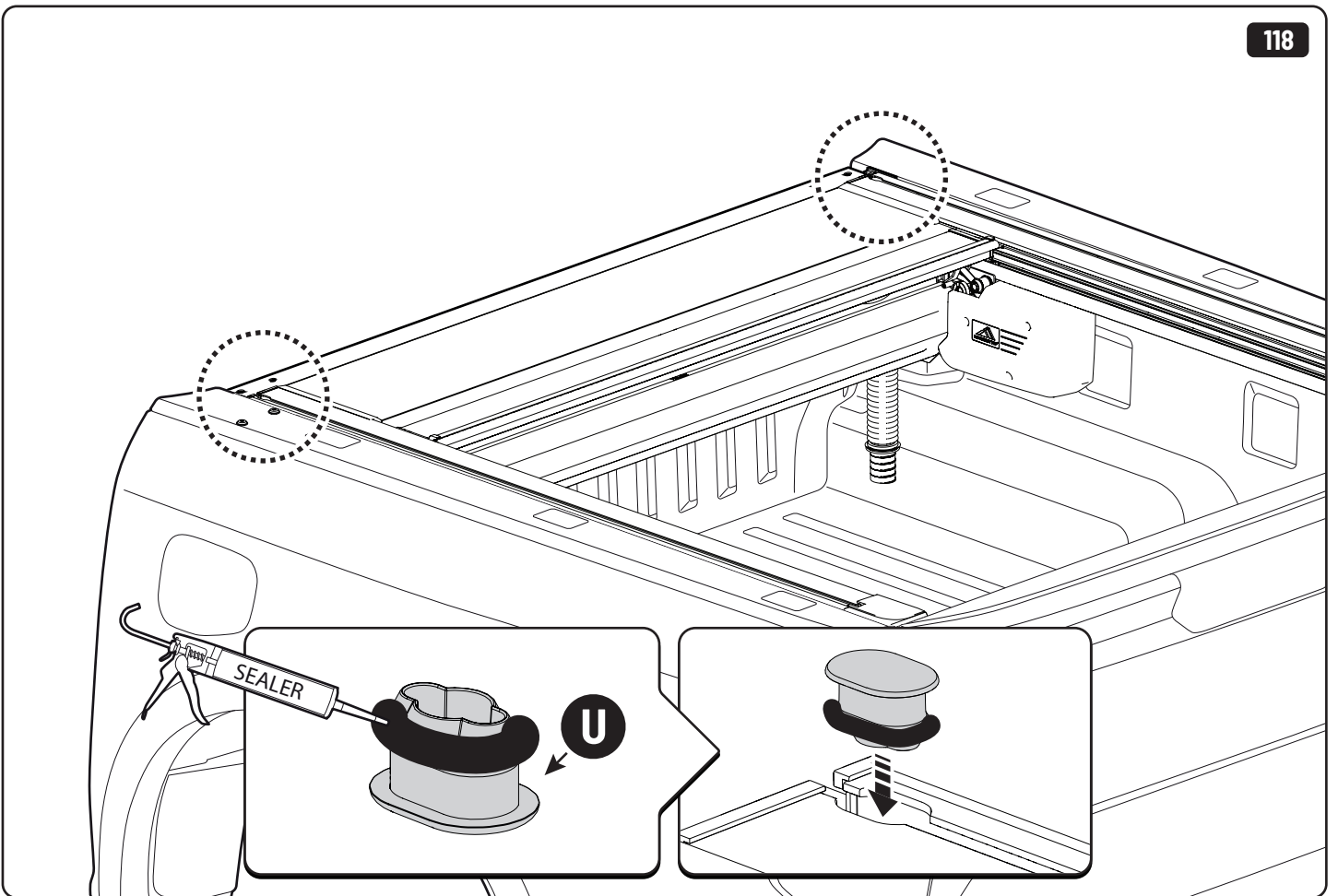
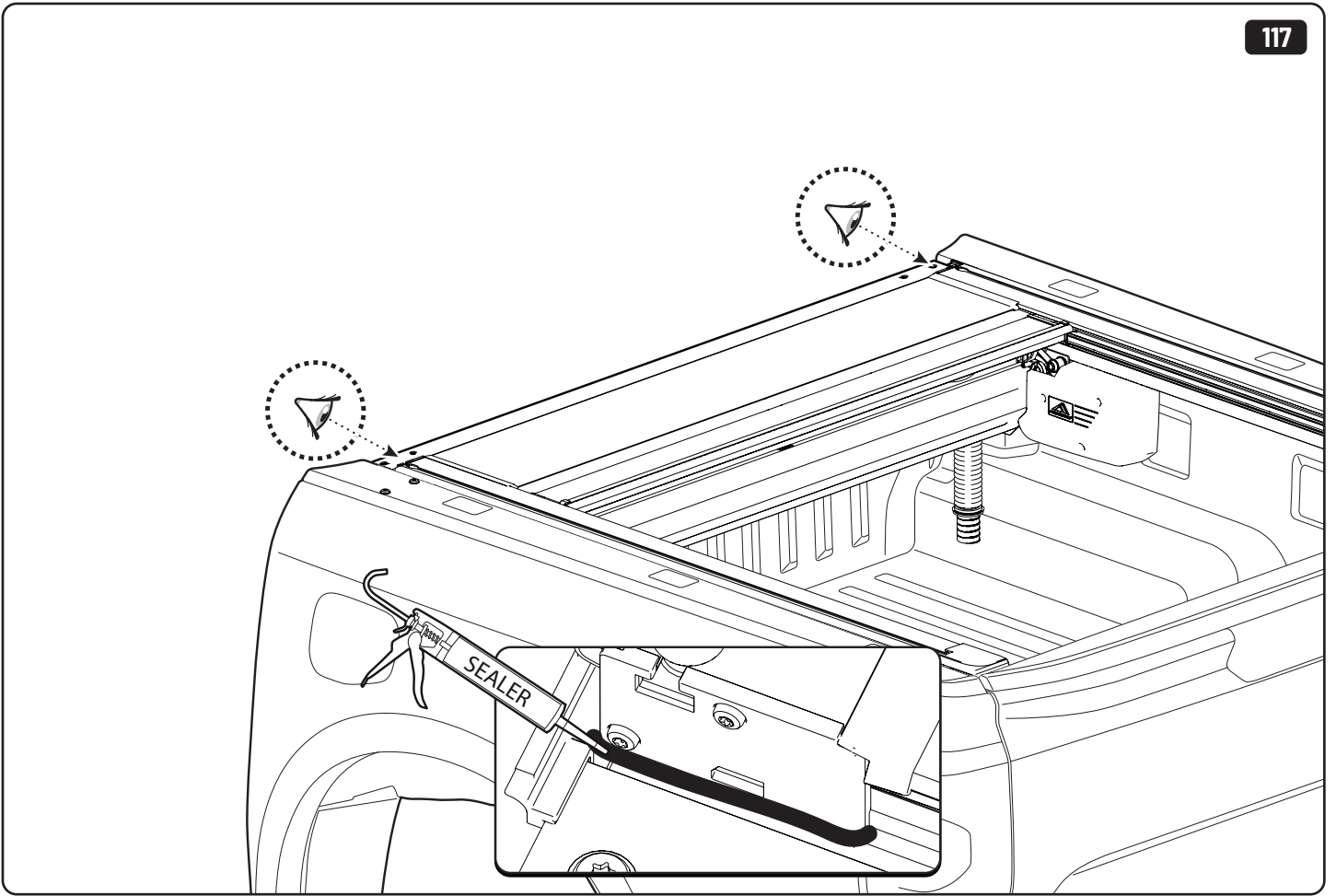

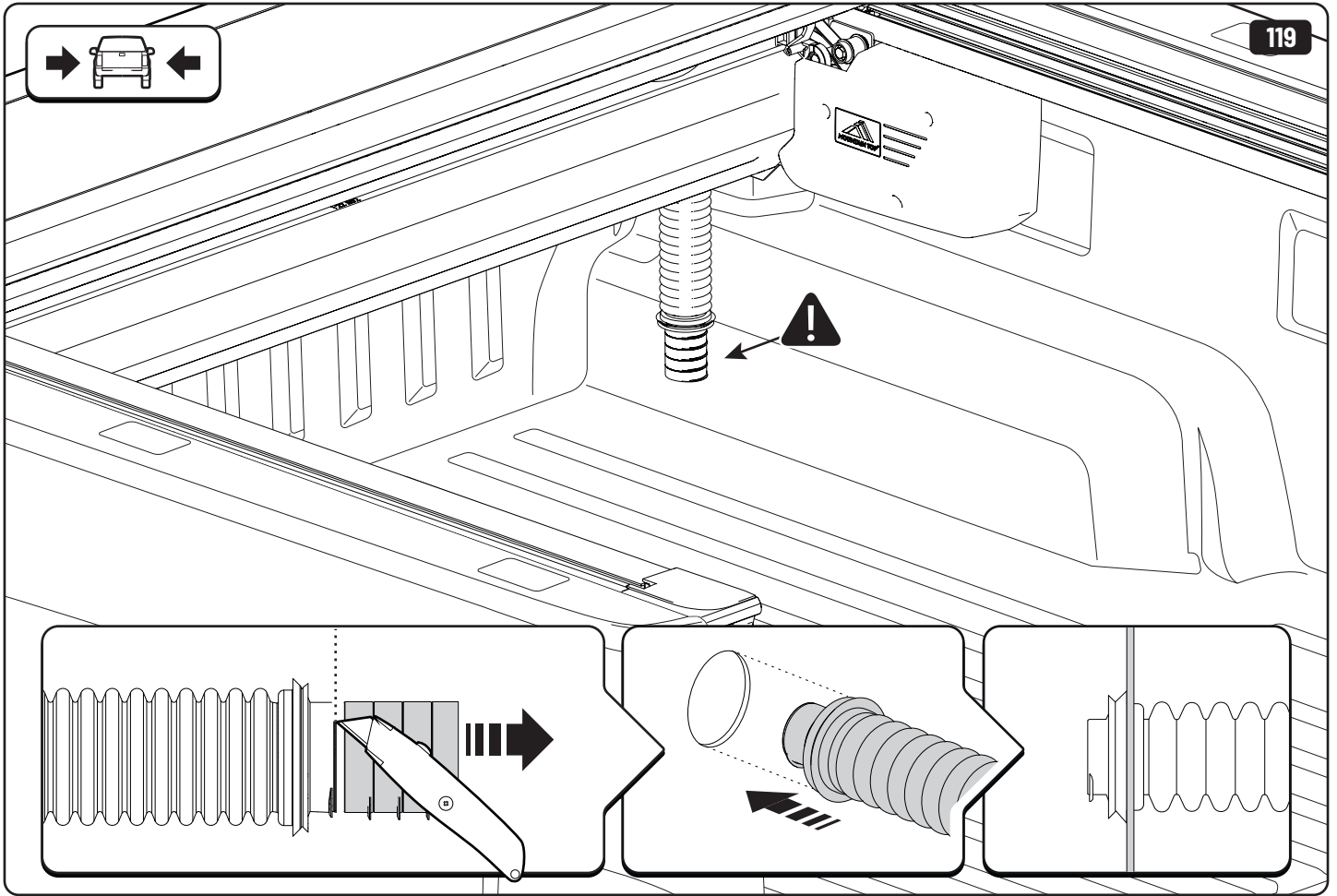
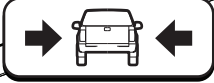

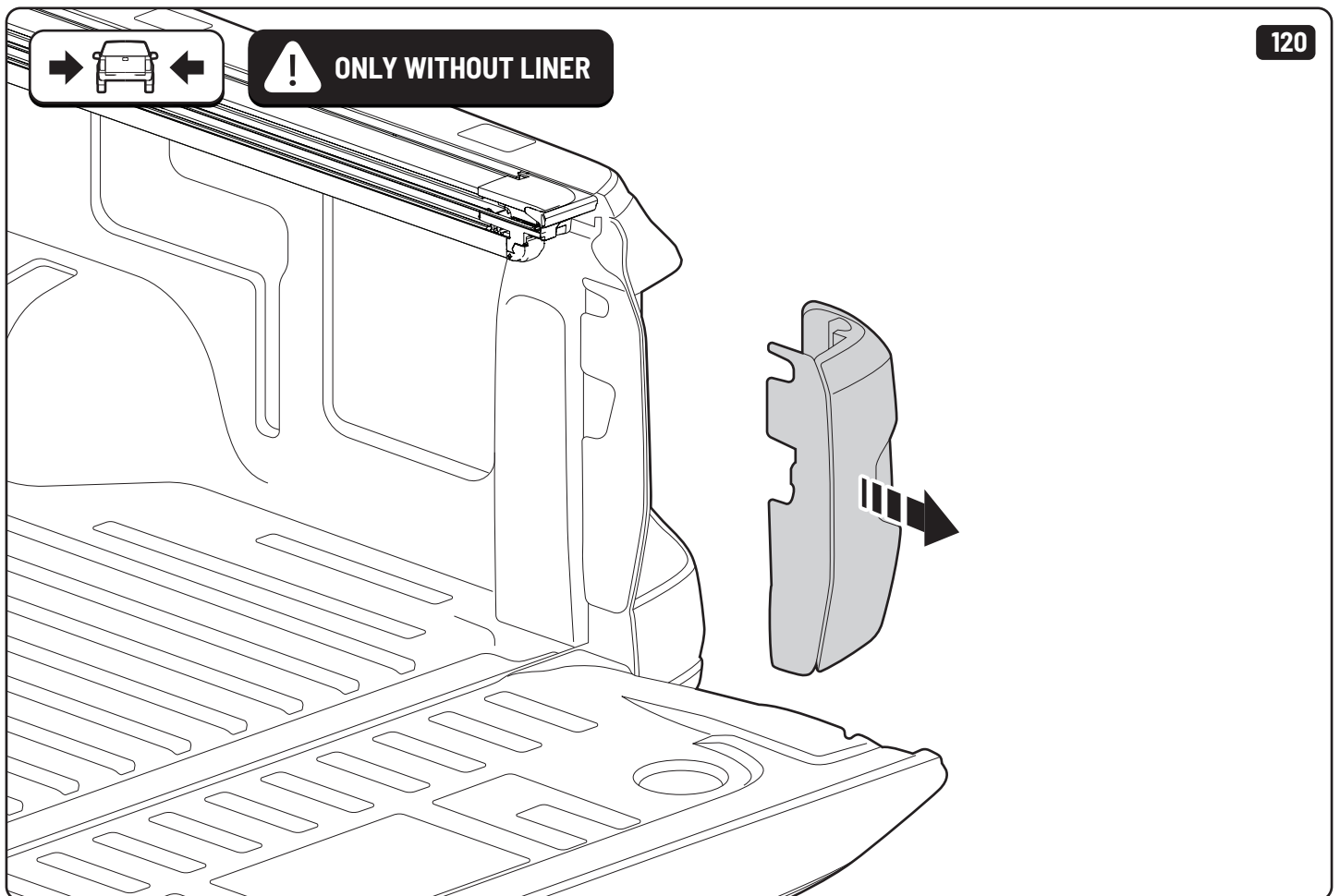
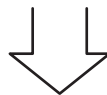
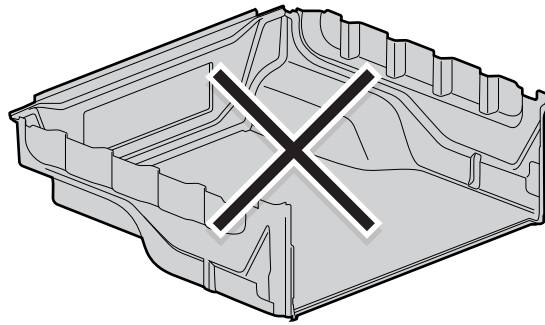
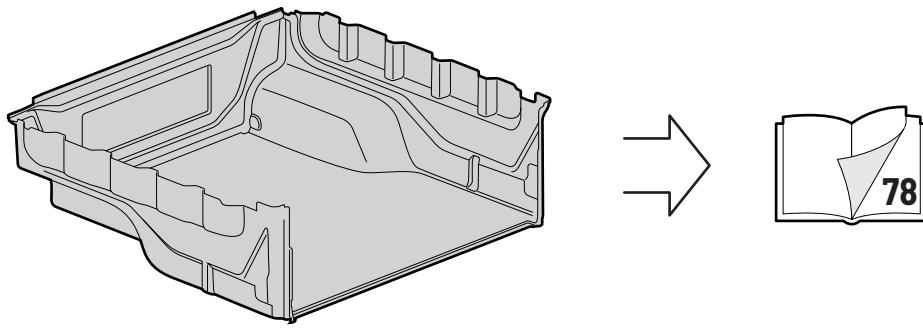



! ONLY WITHOUT LINER

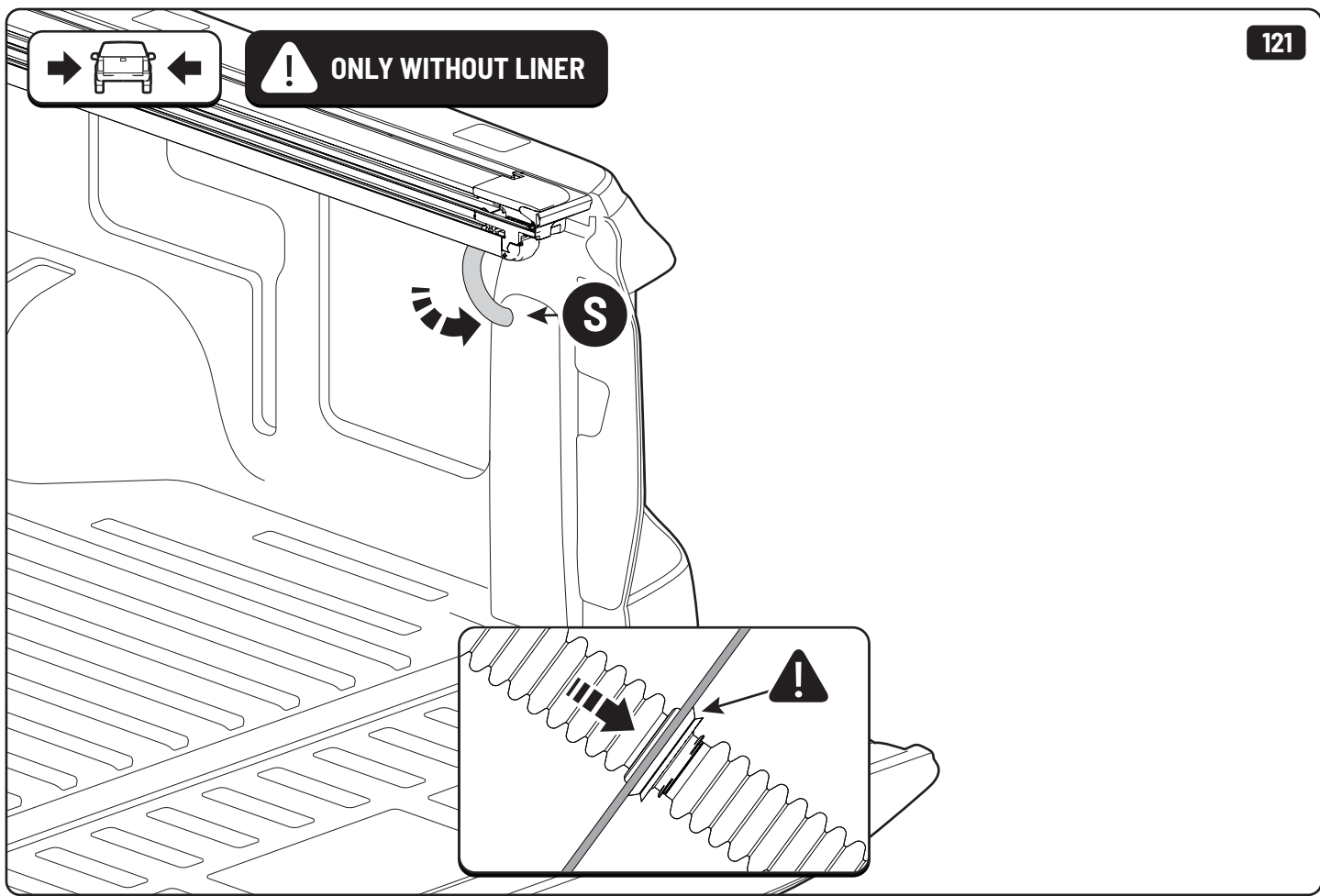

! ONLY WITHOUT LINER

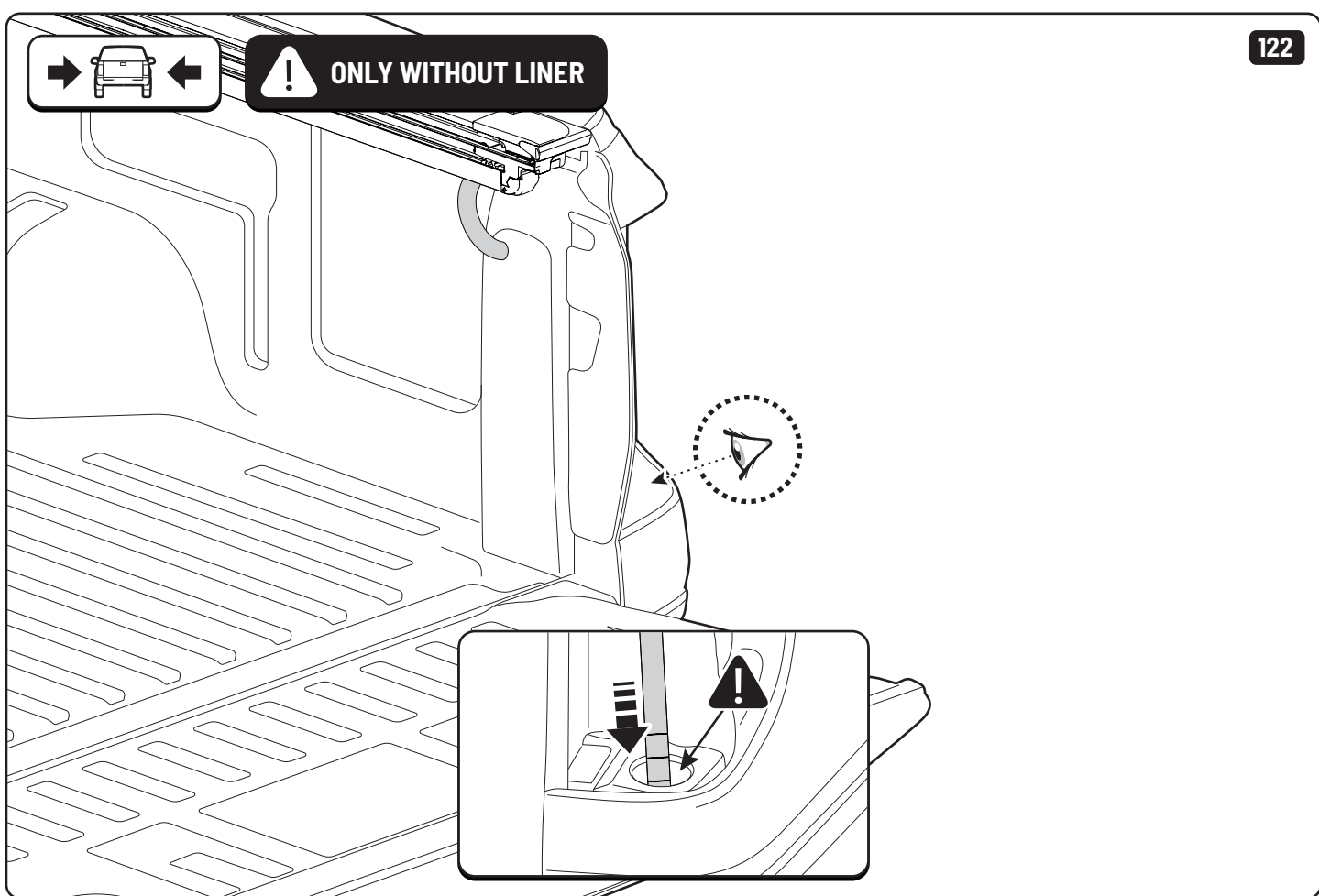



! ONLY WITHOUT LINER

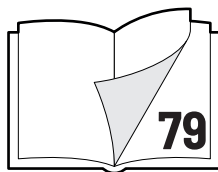
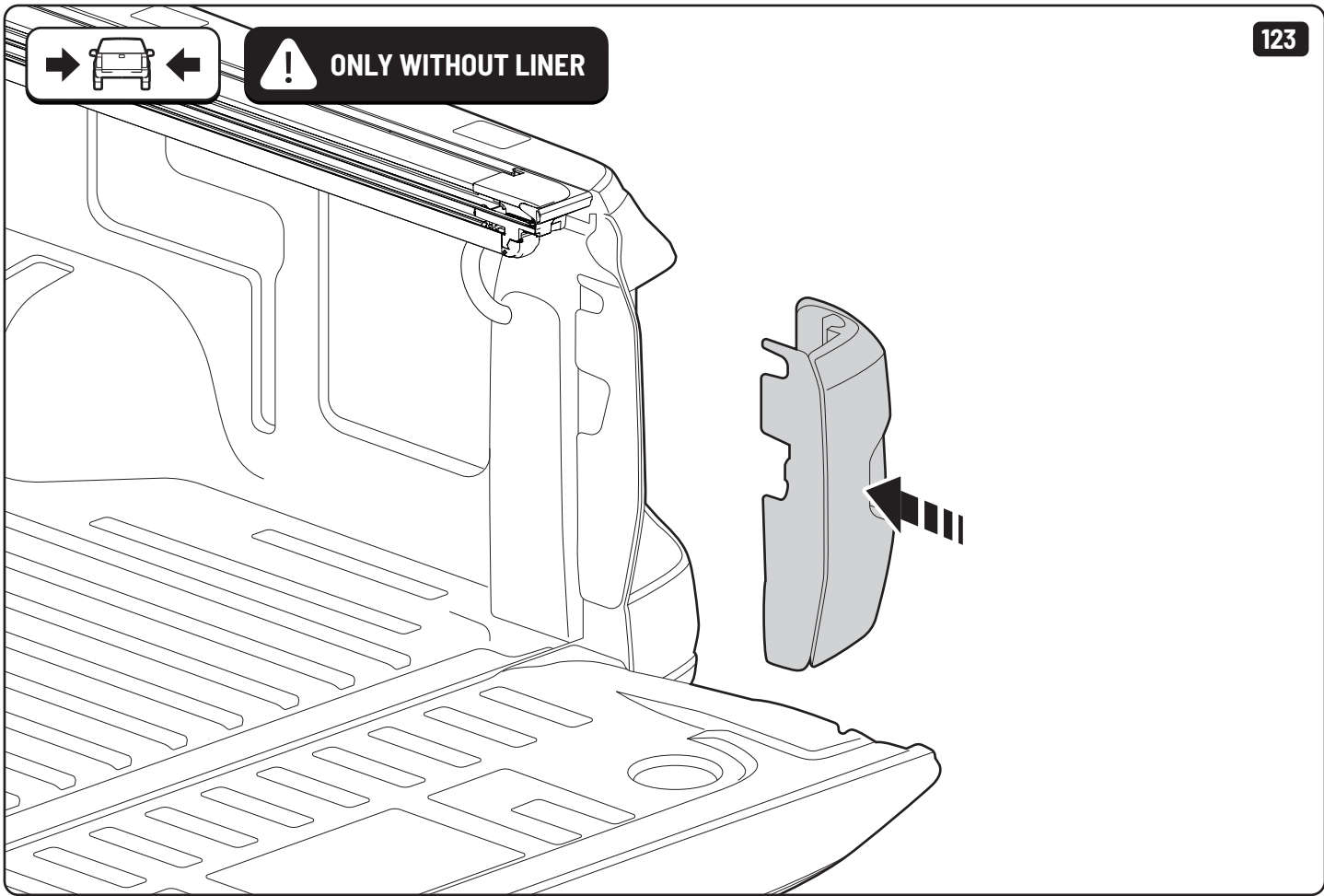

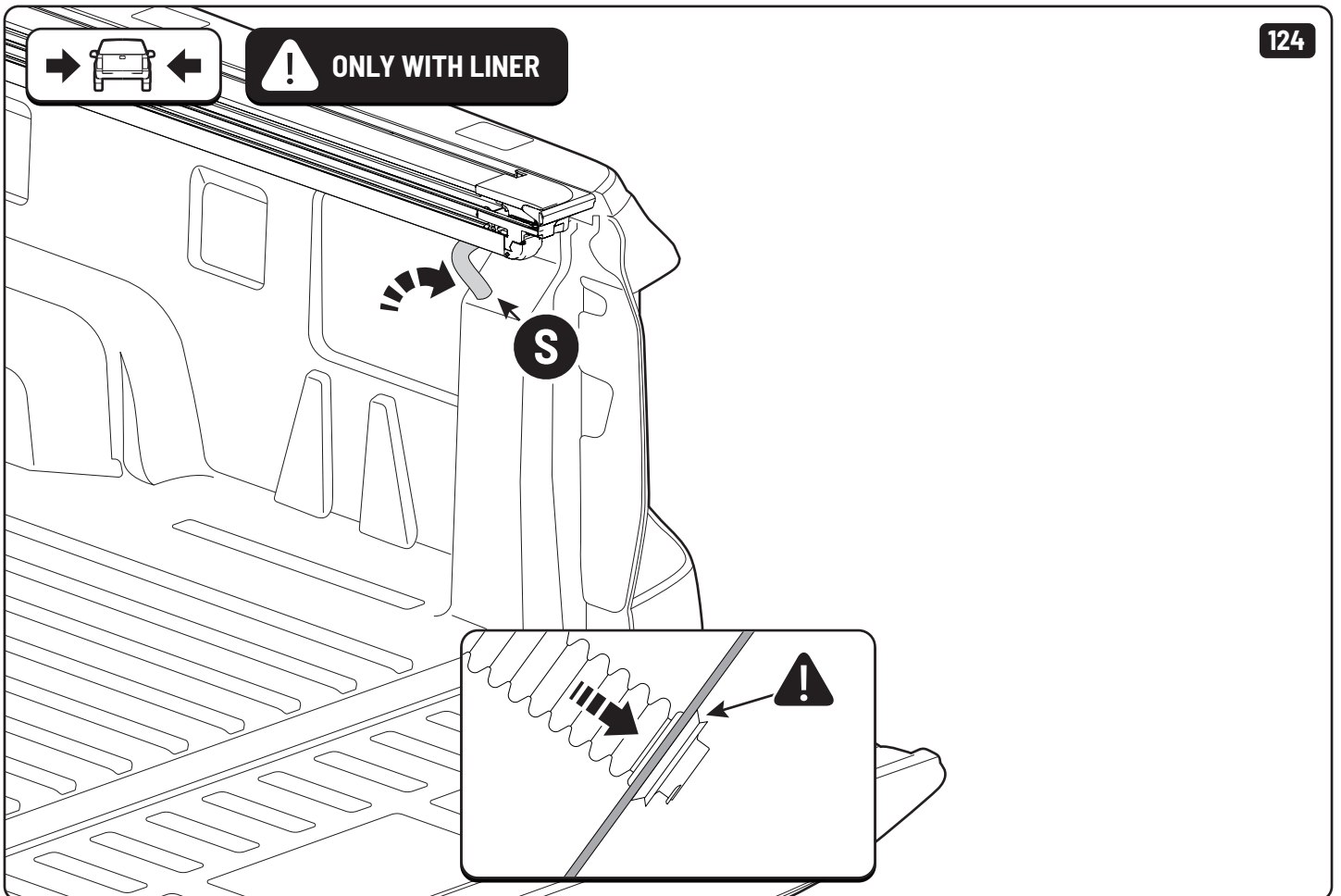
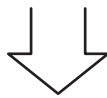
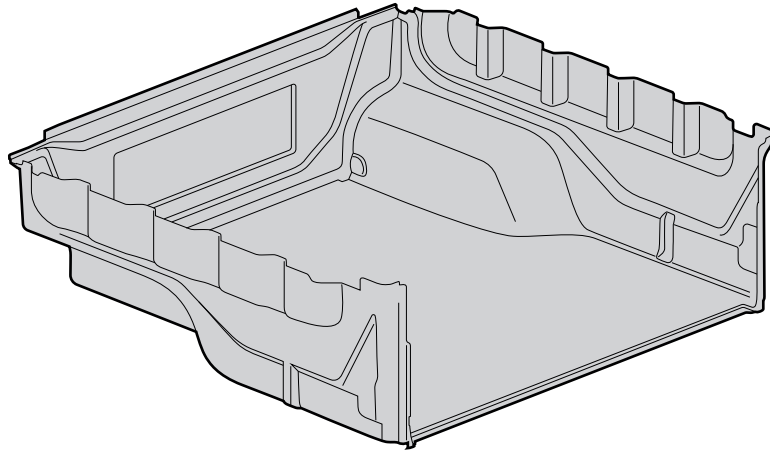

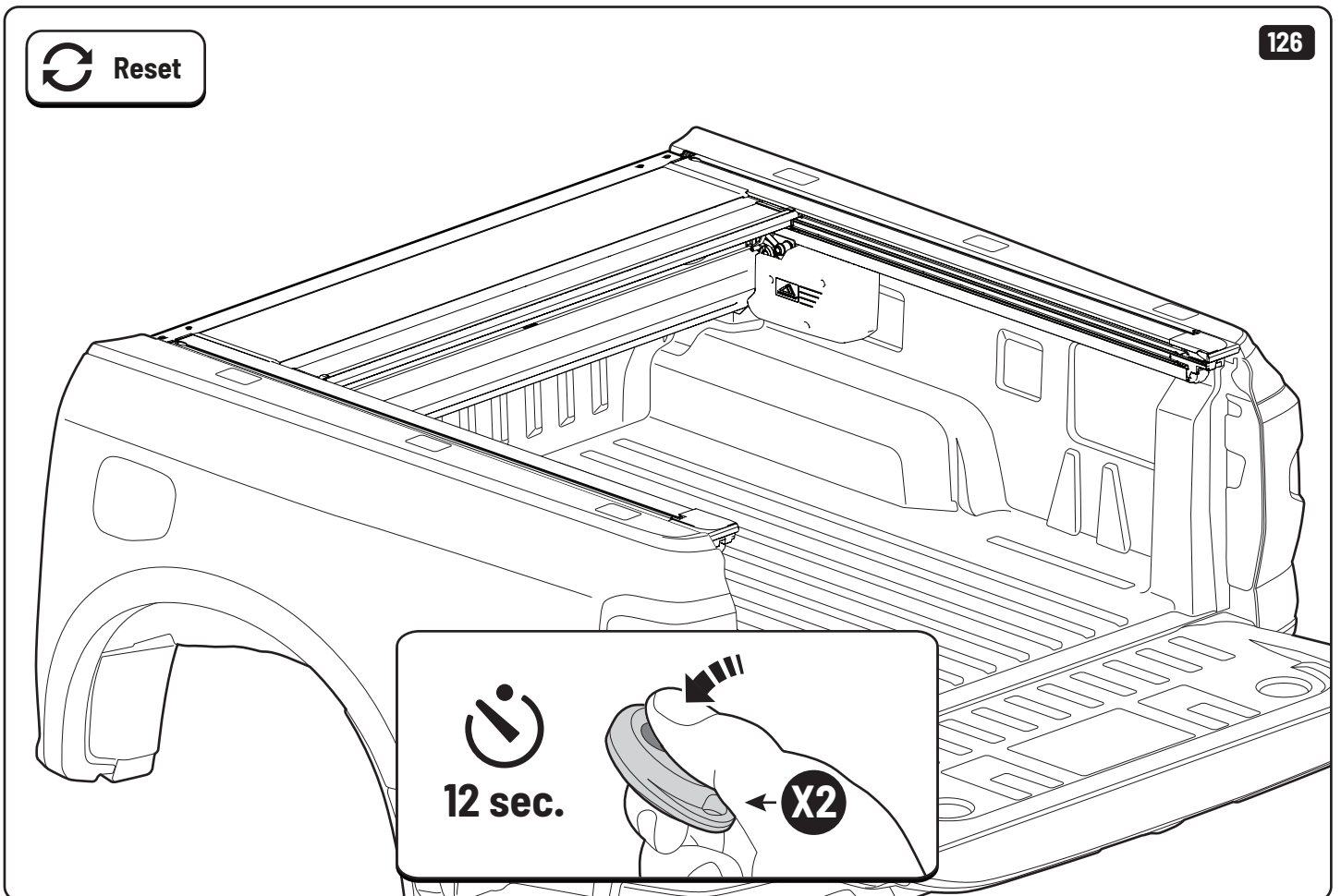
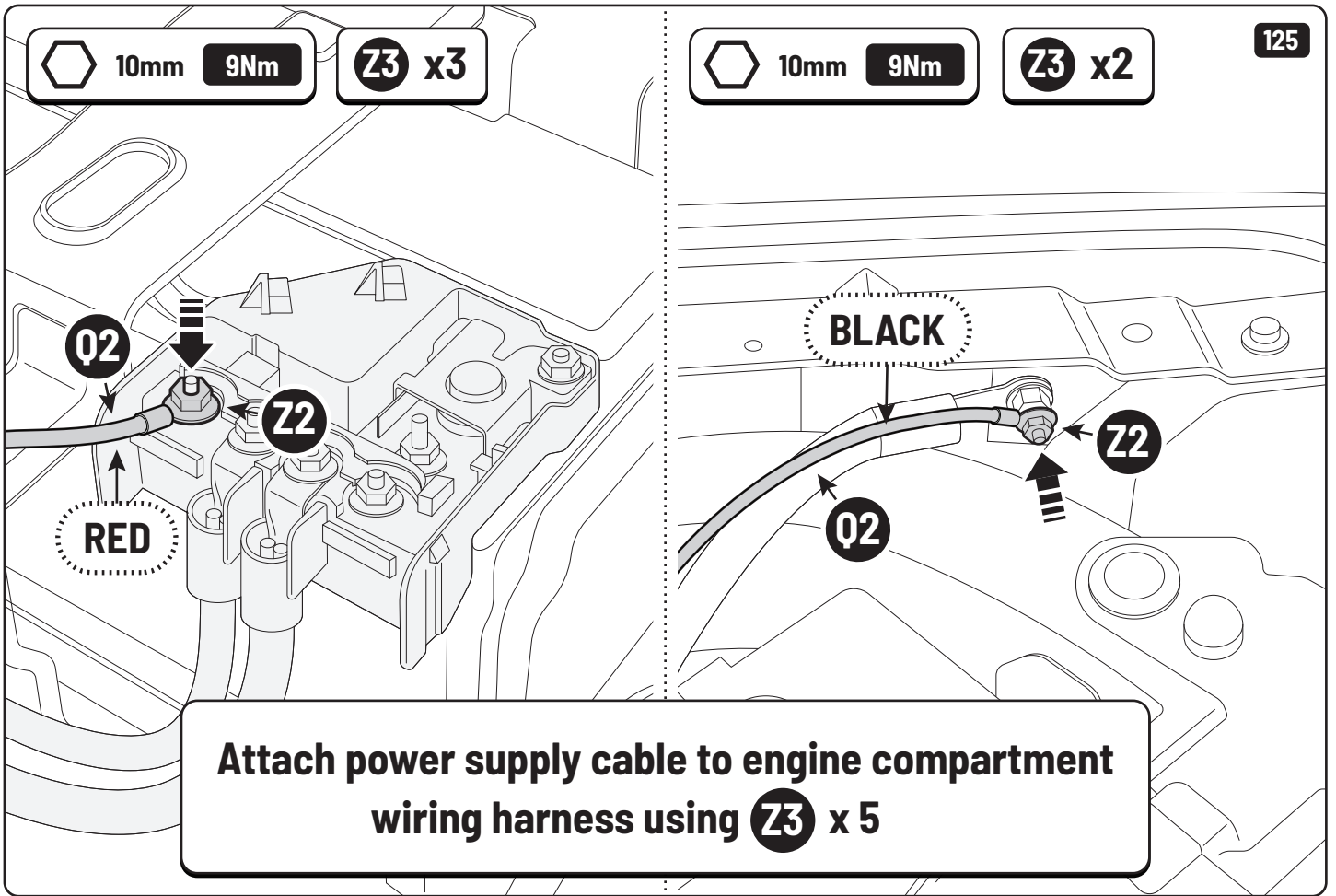

 Reset

127

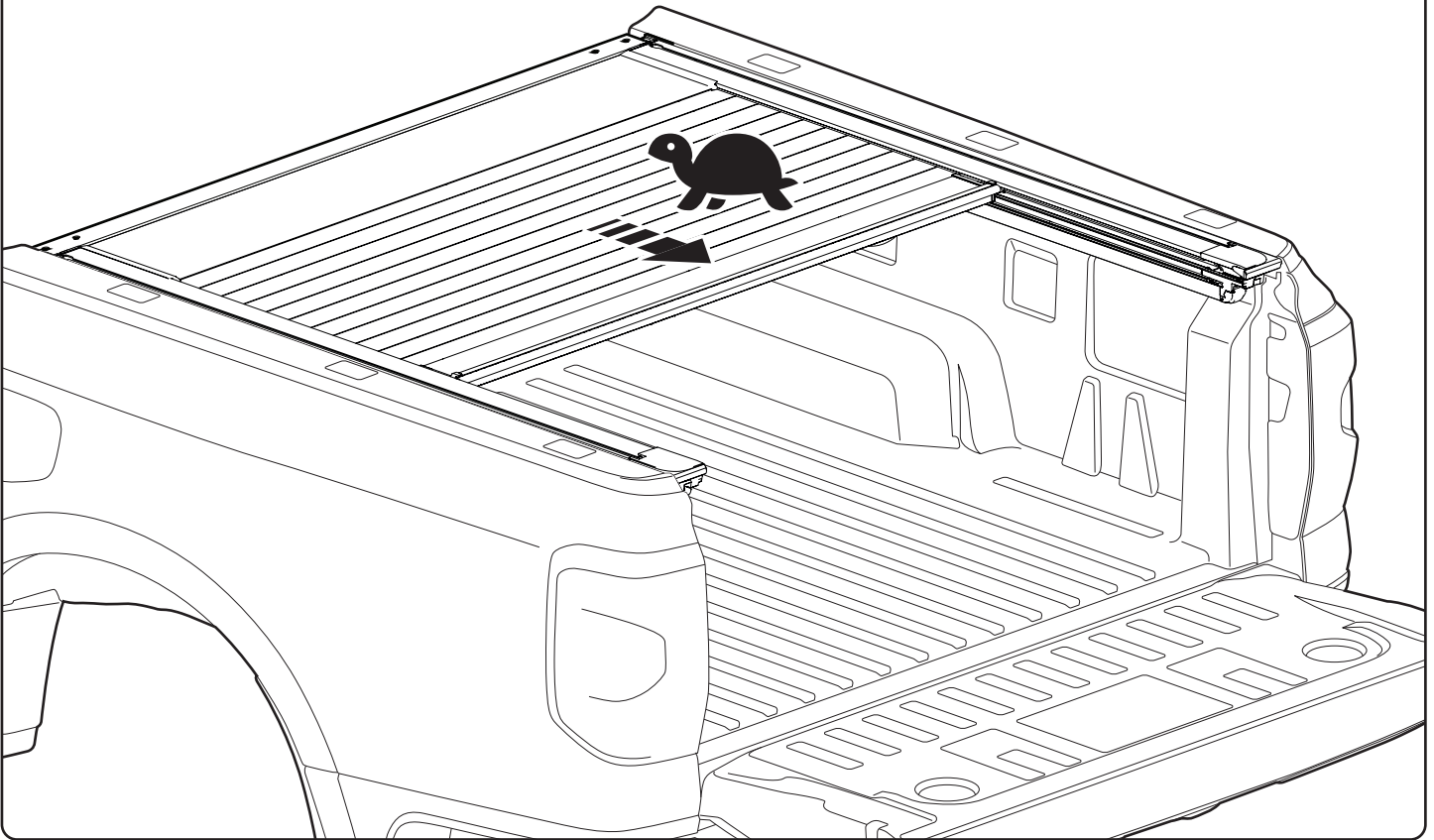

128

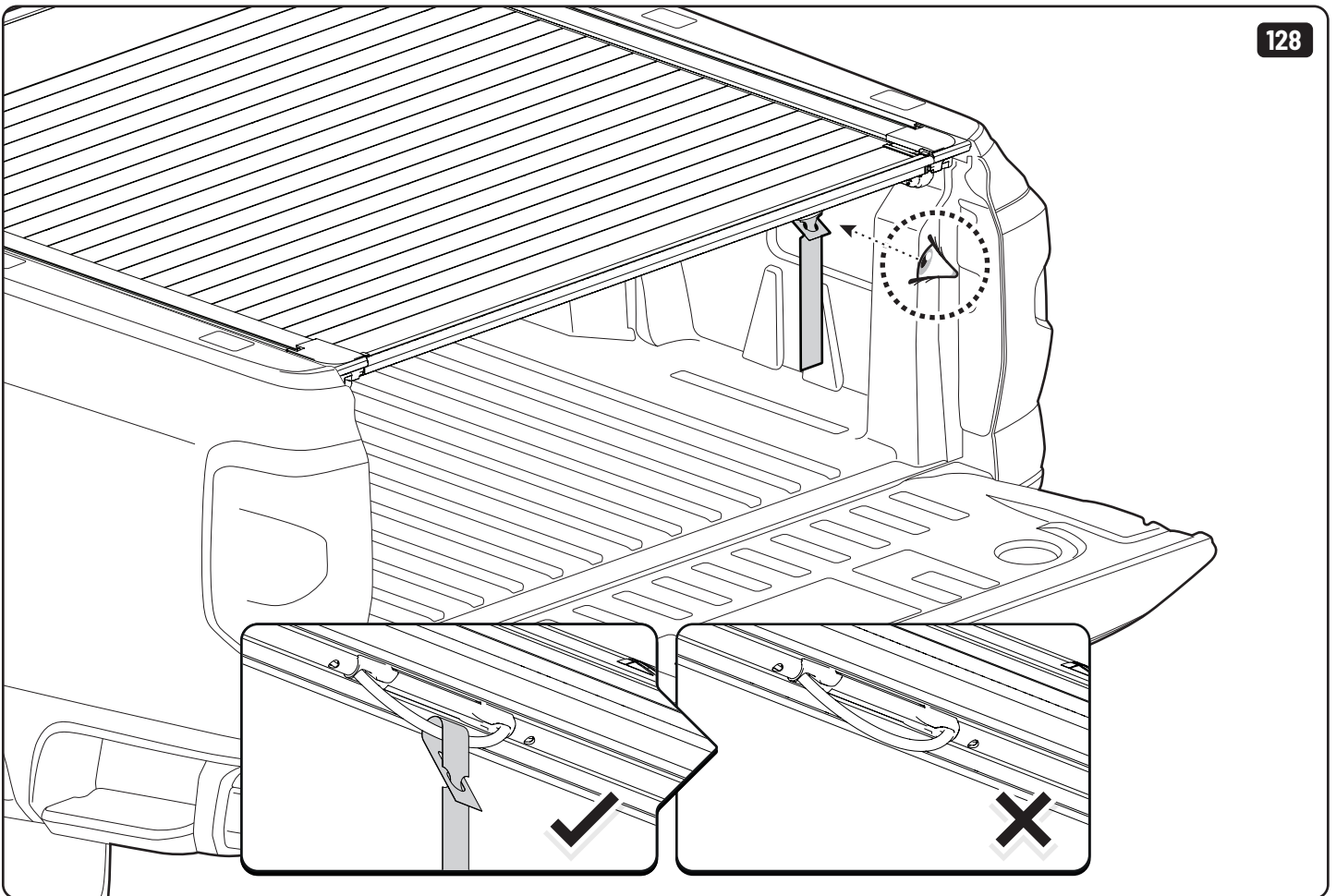

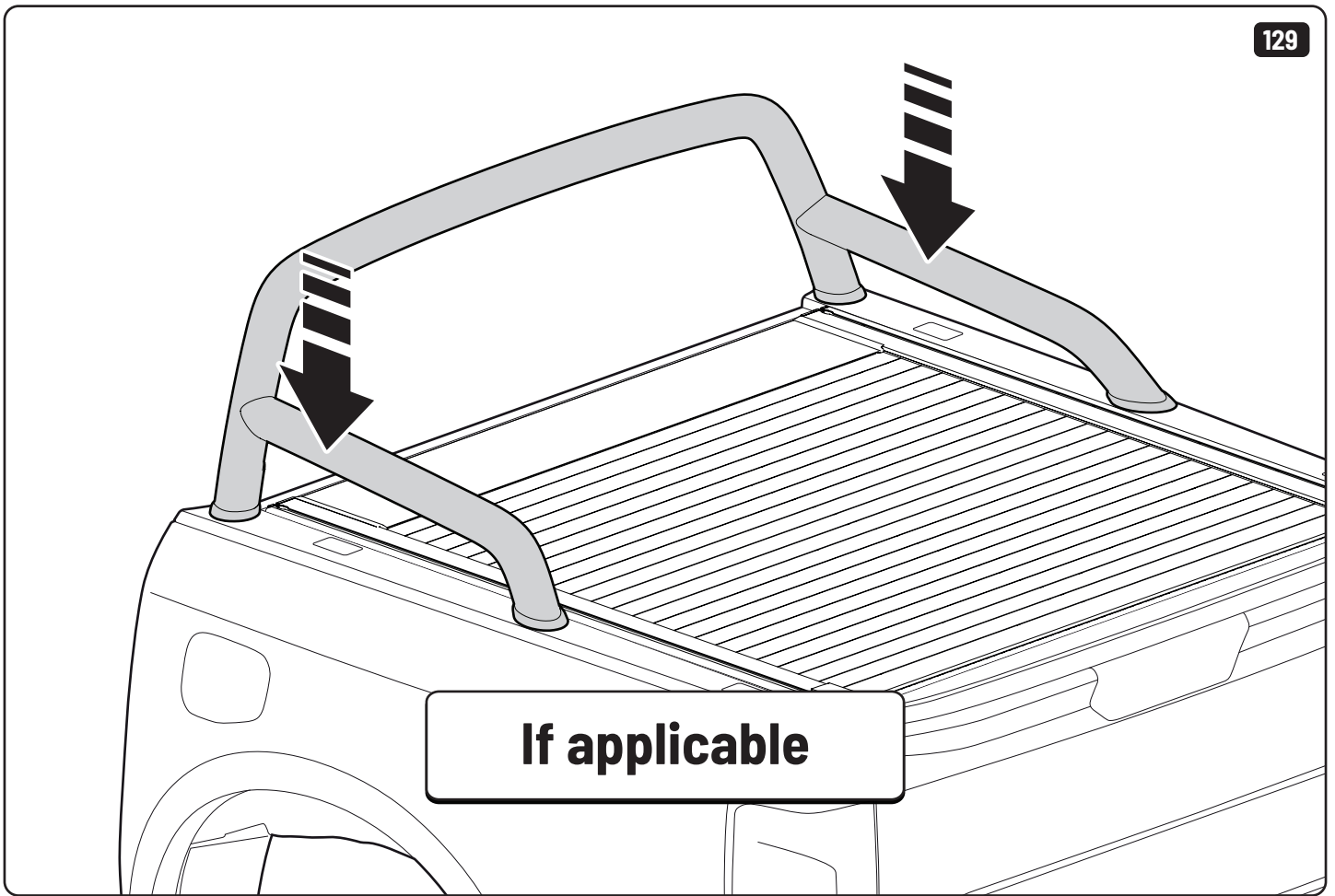

If applicable



| Steps | Page | Done by |
|-----------------------------------|---------------|---------|
| Mounting gliding rail in canister | 19-20 | |
| Holes for drain | 34-37 / 39-43 | |
| Width + Cross measurement | 70+71 | |
| Tightening bracket screws | 70-72 | |
| Mounting drain | 74+75-77 / 78 | |
| Calibrate EVOe | 79-80 | |



Customer Service +45 4810 2950 (08:00 - 16:00 CET)
Support info@mountaintop.dk
Website www.mountaintop.dk
Address Pedersholmparken 10, 3600 Frederikssund, Denmark

| Part number (s) | Model / Year | Cab type (s) | Installation time | Weight |
|-----------------|----------------------|--------------|-------------------|--------|
| EVOe FO10 HB02 | Ford Ranger/ 2022 -> | Double Cab | 2 hour (s) | 33 kg |
| EVOe FO11 HB02 | Ford Ranger/ 2022 -> | Rap Cab | 2 hour (s) | 40 kg |

| | | |
|-----------------------------------|------------------------------------|-------------------------------------|
| GB Installation manual | S Monteringsanvisning | D Einbauanleitung |
| SF Asennusohje | E Instrucciones de montaje | CZ Návod k instalaci |
| F Notice de montage | H Szerelési utasítás | I Istruzioni di montaggio |
| PL Instrukcja montażu | P Instruções de instalação | GR Οδηγίες Εγκατάστασης |
| NL Installatie-instructies | RUS Инструкция по установке | DK Monteringsvejledning |
| TR Montaj Talimatı | N Monteringsveiledning | RO Instructiuni de instalare |