

**18C
4017N**

VW T6, Modell 2019

EU-Spoilerschutzrohr 51 mm gekröpft
EU-Spoiler protective tube 51 mm cranked
Tube de protection du spoiler vinklud CE 51 mm



*Compatible with Automatic Cruise Control /Forward Collision Mitigation
Kompatibel mit Abstandsregeltempomat /Auffahrvermeidungs-oder warnsystem
compatible avec radar de régulation de distance/ freinage autonome d'urgence

ASSEMBLY INSTRUCTION

Montageanleitung • Instructions de montage

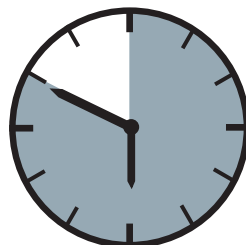

50 Minuten

article no.:

18C4017N (S) inox

18C5017N black steel

Revision 2: 06.02.2020



ULLSTEIN
CONCEPTS
GMBH

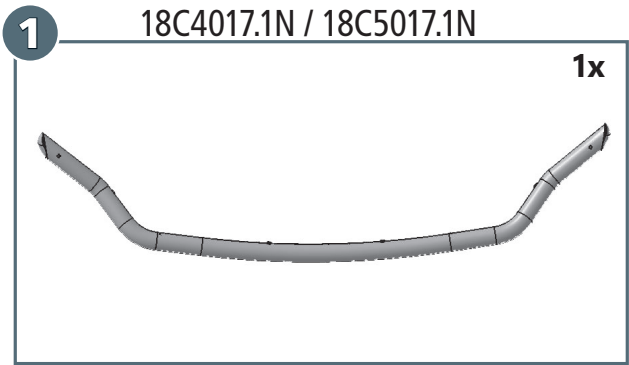
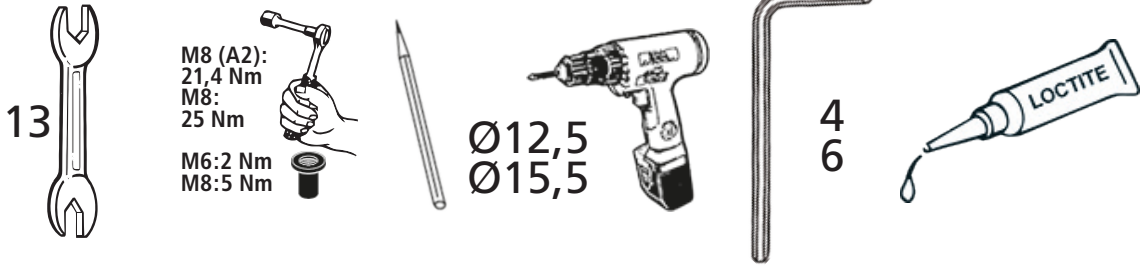

mounting kit: 18C9017N

	M8x25; DIN 933 A2	4x
	M8x25; DIN 933 Zn	2x
	M8x16; DIN 933 Zn	4x
	M6x30; DIN 912 A2	2x
	M6x25; DIN 7991	4x
	Ø 6,4; DIN 125 A2	2x
	GETO-WELL M6	6x

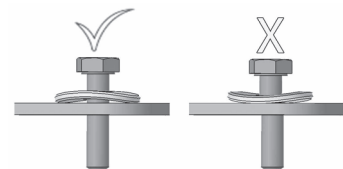
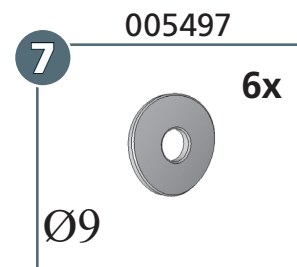
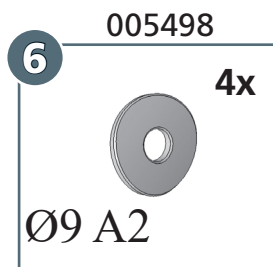
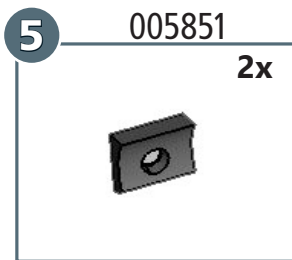
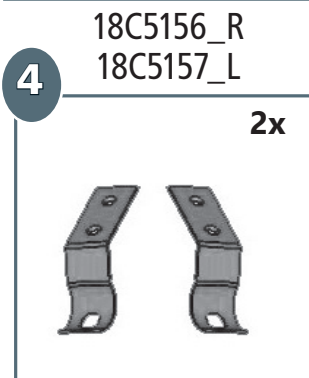
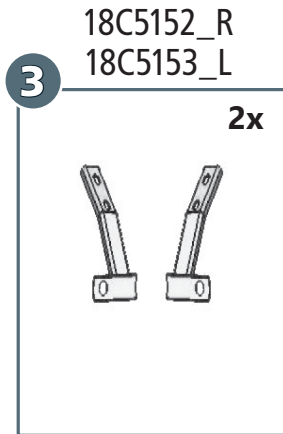
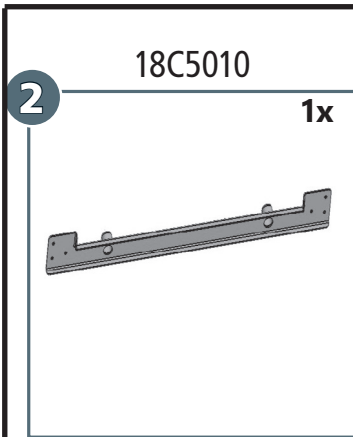

article no.:
18C4017N (S) inox
18C5017N black steel

Revision 2: 06.02.2020



ULLSTEIN
CONCEPTS
GMBH

page/Seite 2

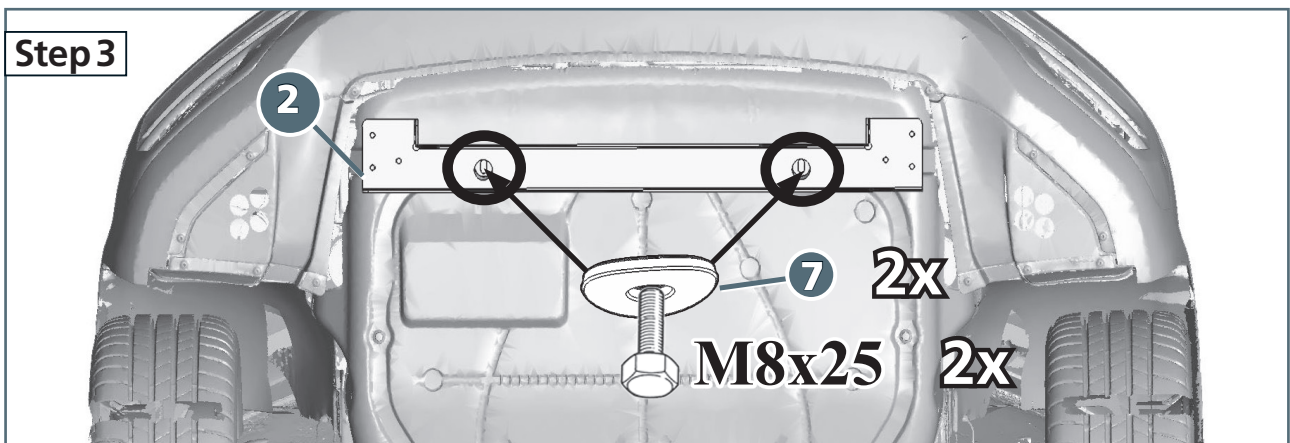
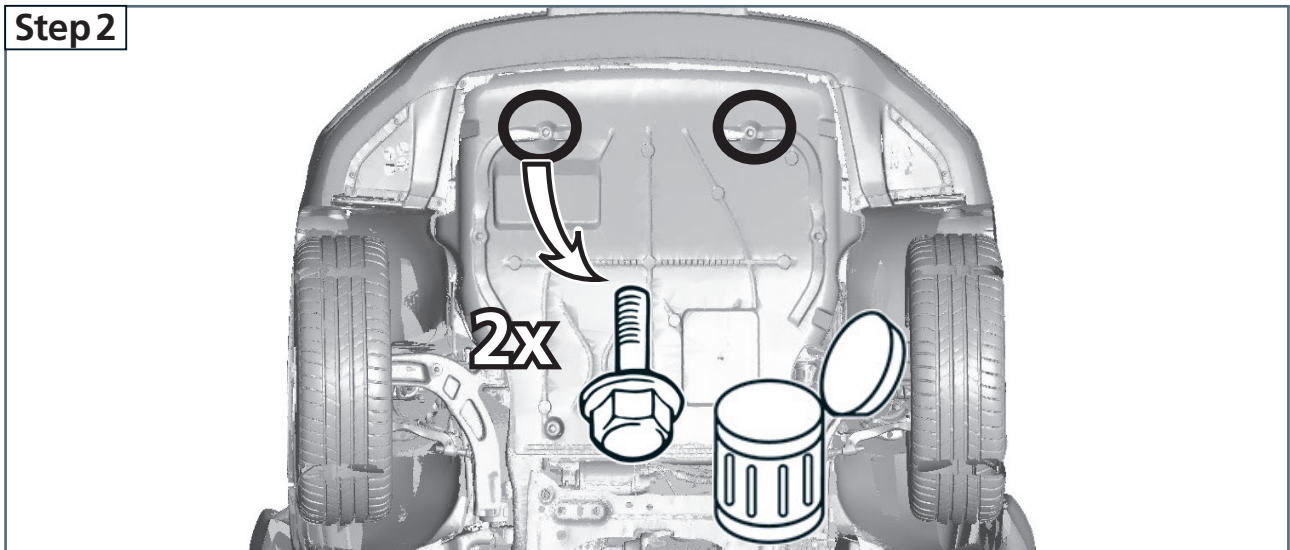
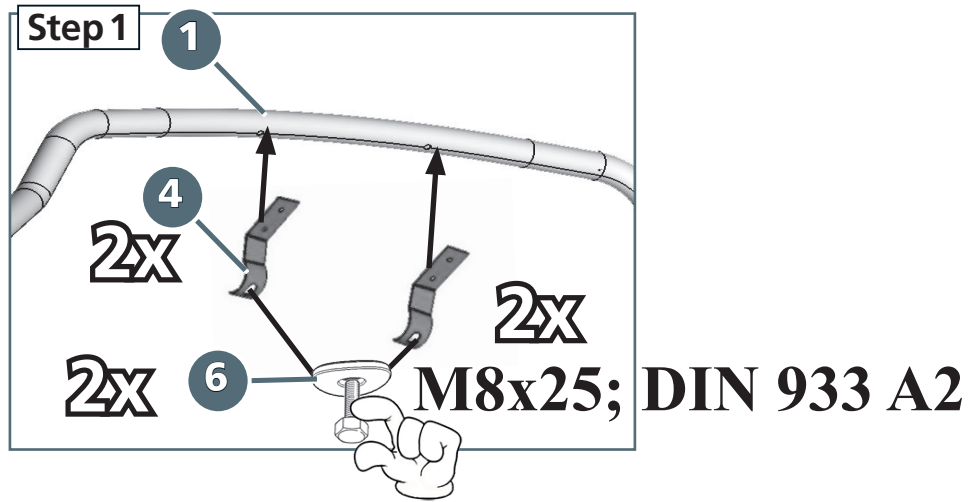

Revision 2: 06.02.2020

Step 5

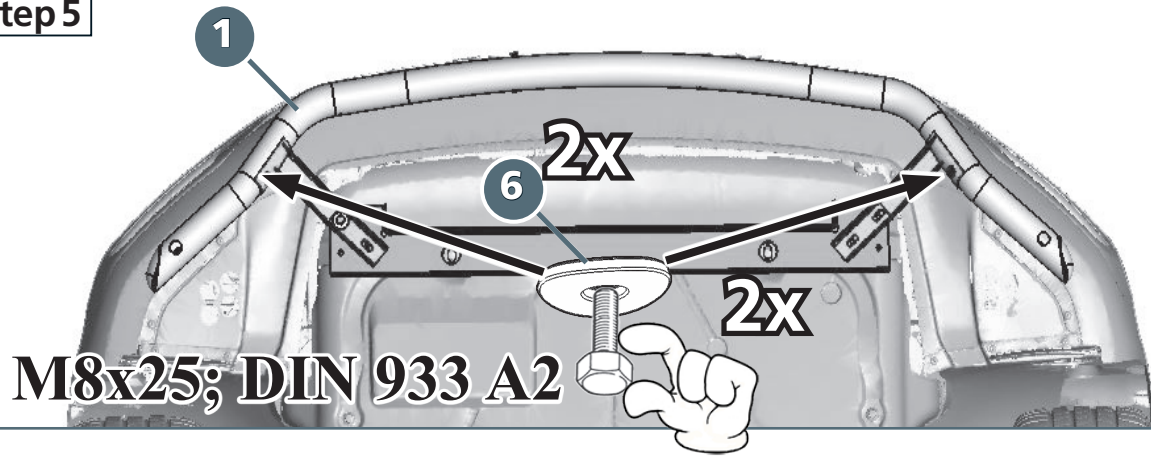

Step 6

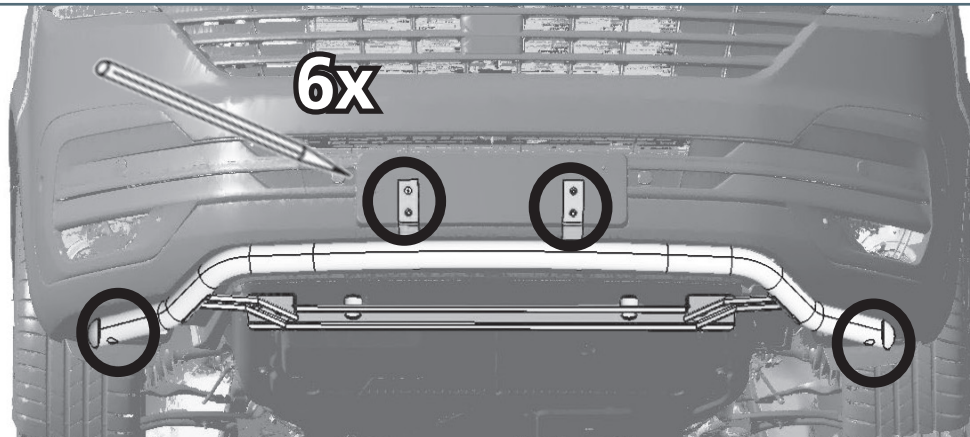

Step 7

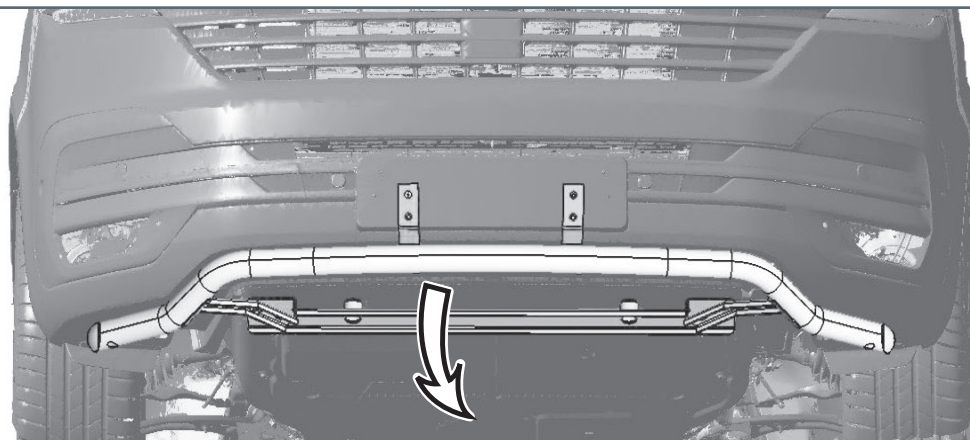

Step 8

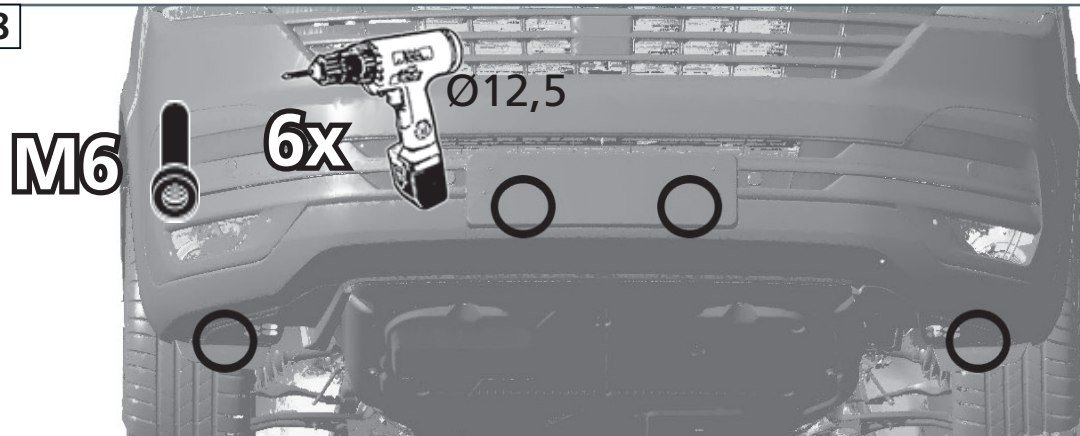

Step 9

5
2x

Ø6,4; DIN 125 A2
M6x30-A2

2x

4x
M6x25; DIN 7991

Step 10

M8 (A2):
21,4 Nm
M8:
25 Nm

M6: 2 Nm
M8: 5 Nm

Step 11

