

17W
4419

Mitsubishi L200 CC, Md. 2015+Md.2020

Roll bar 60
Überrollbügel 60
Arceau 60



ASSEMBLY INSTRUCTION

Montageanleitung • Instructions de montage

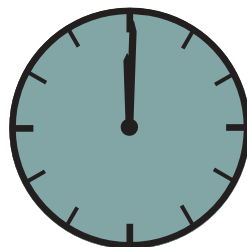

60 Minuten

article no.:

17W4419 (S) inox

17W5419 black steel

Revision 5: 16.10.2019



ULLSTEIN
CONCEPTS
GMBH

www.ullsteinconcepts.com



8
13
17



M5(A2): 5,1 Nm
M8(A2): 21,4Nm
M10(A2): 44Nm
M10: 50 Nm

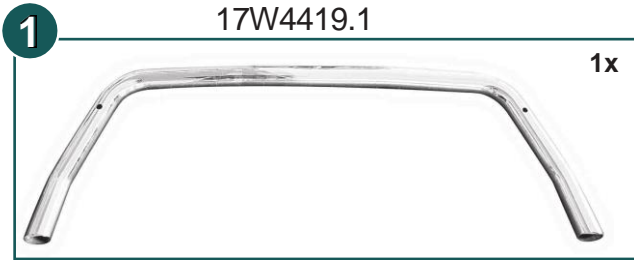
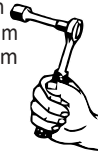

mounting kit: 17W9419

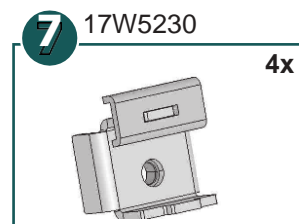
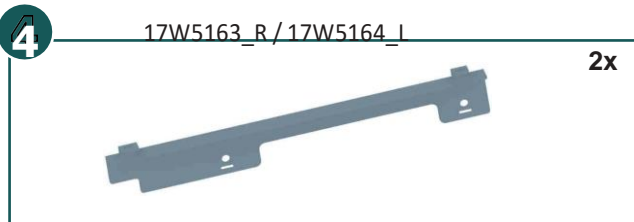
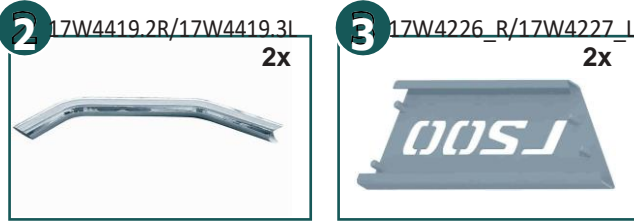

	M10x30; DIN 912 A2	2x
	M5x20(25); DIN 933 A2	8x
	M8x30; DIN 933 A2	4x
	M10x40; DIN 933 Zn	4x
	M5; DIN 985 A2	8x
	Ø8; DIN 127 A2	4x
	Ø5,3; DIN 125 A2	16x
	Ø8,4; DIN 125 A2	4x
	Ø10,5; DIN 125 Zn	4x
	SW8	16x
	SW17	4x
	Gummi Stopfen Art.Nr.0561 116	2x

Step 1

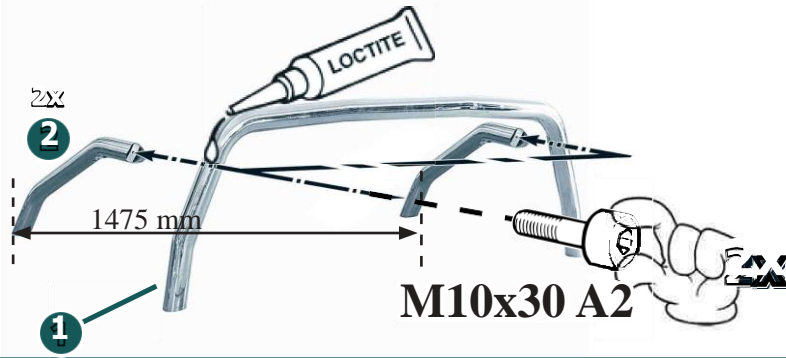

Step 2

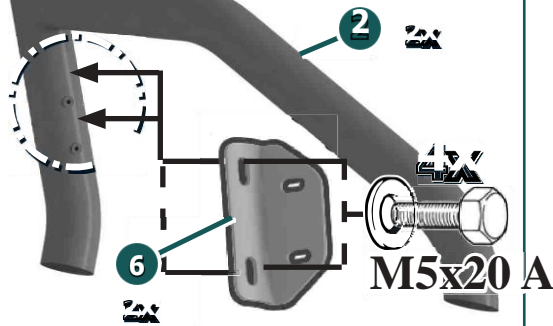

Step 3

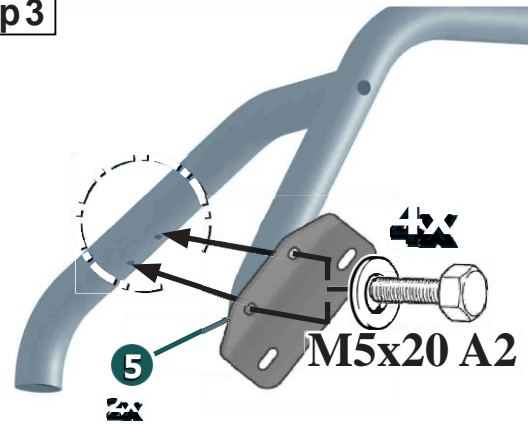

Step 4

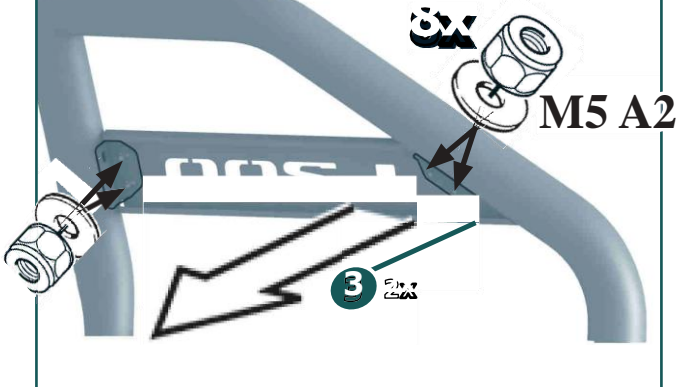

Step 5

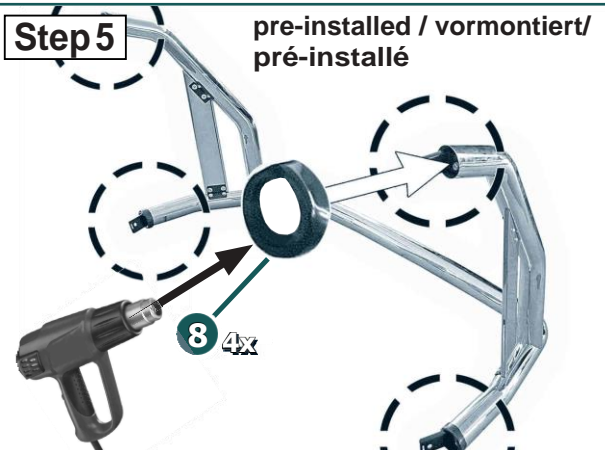

Step 6

