

# INSTALLATION INSTRUCTION

## BED LINER DBL 5 PCS









Ullstein Concepts GmbH  
 Bahnhofstr. 20  
 85416 Langenbach  
 Deutschland  
 phone: +49 (0) 89 809902880  
 fax: +49 (0) 89809902888  
 mail: mail@ullsteinconcepts.com  
 www.ULLSTEINCONCEPTS.com

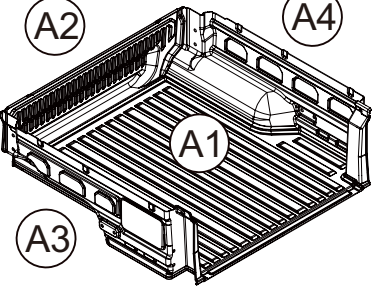
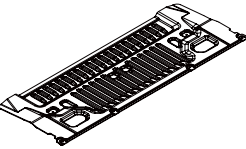
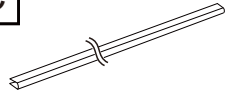
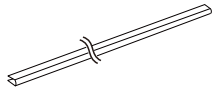

ULLSTEIN  
 CONCEPTS  
 GMBH

FORD RANGER 2022 (EU) &   
 VW AMAROK 2022

<p><b>A</b></p>  <p>x1</p>	<p><b>B</b></p>  <p>x1</p>	<p><b>C</b></p>  <p>Front PVC ( L=970 mm.) x 1</p>	<p><b>E</b></p>  <p>Tailgate Seal ( L=1350mm.) x 1</p>		
<p><b>F</b></p>  <p>Plastic push pinx2</p>	<p><b>G</b></p>  <p>Spacer x 12</p>	<p><b>H</b></p>  <p>Bolt M6x2</p>	<p><b>I</b></p>  <p>Washer OD 19mm x 2</p>	<p><b>J</b></p>  <p>Tailgate Washer ID5 OD 20mm x 6</p>	<p><b>K</b></p>  <p>ESCO tape 9mm ( L=825mm.) x 1</p>

102110000865

REV.00

1/8

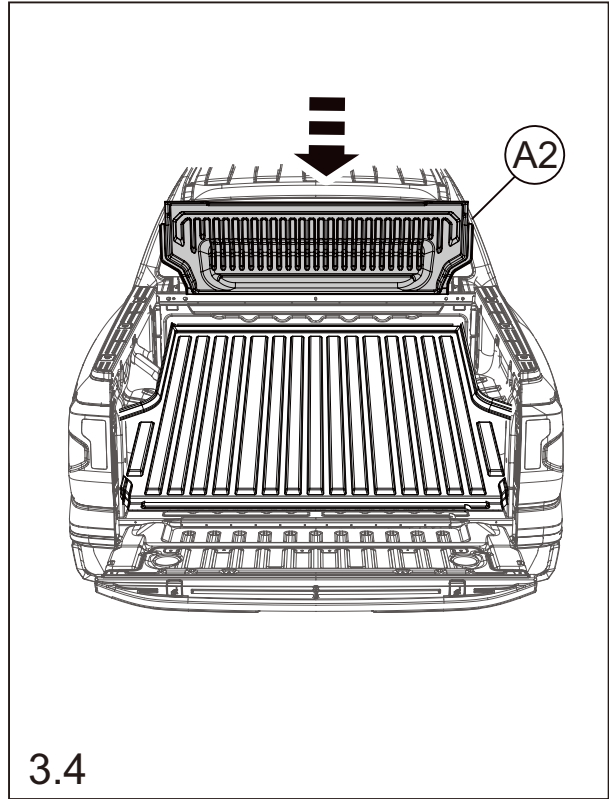
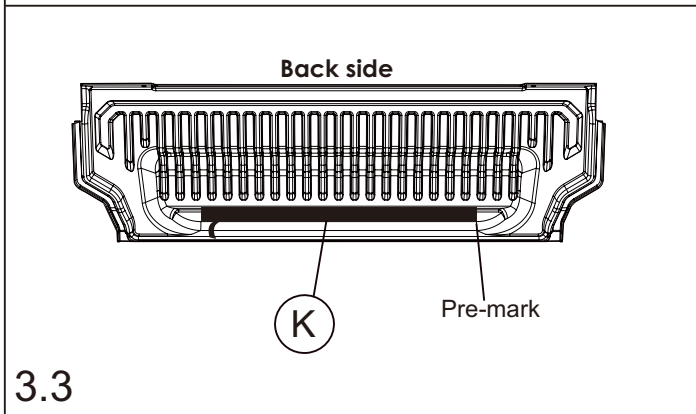
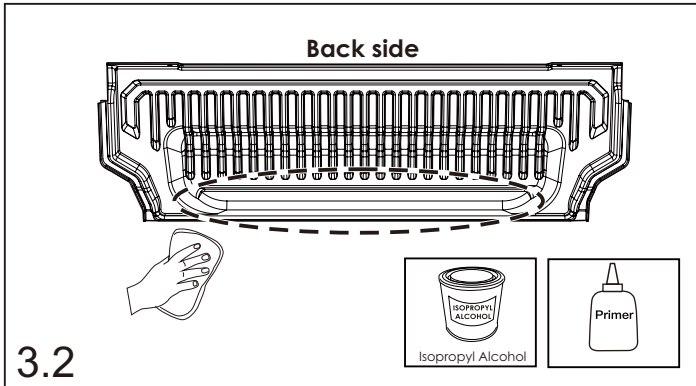
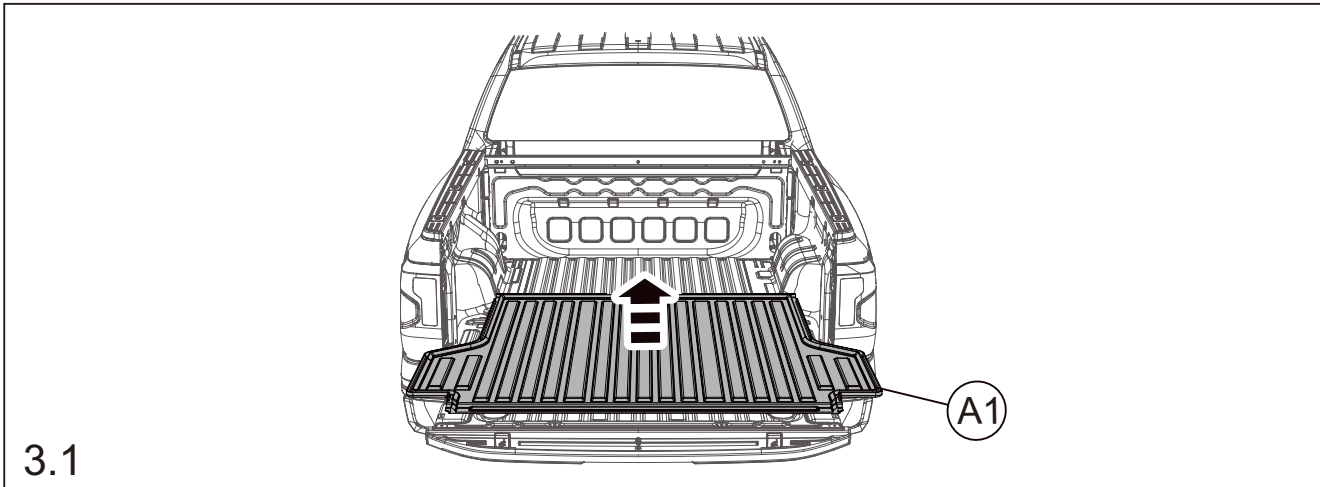
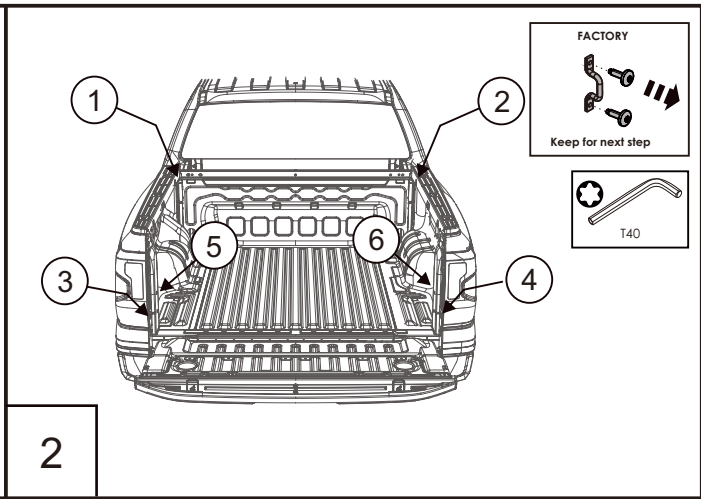
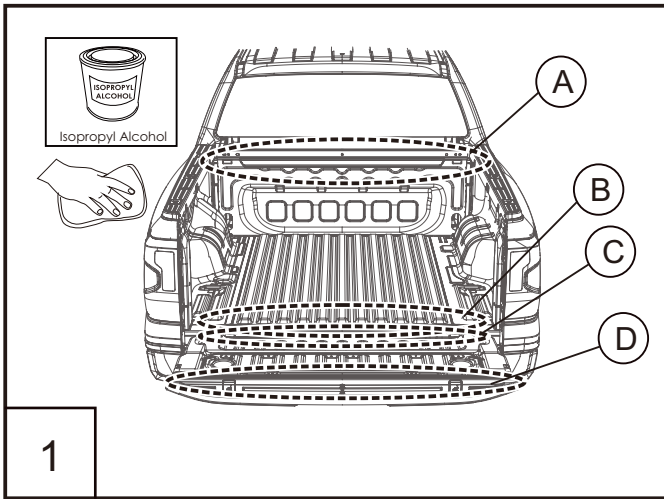

3

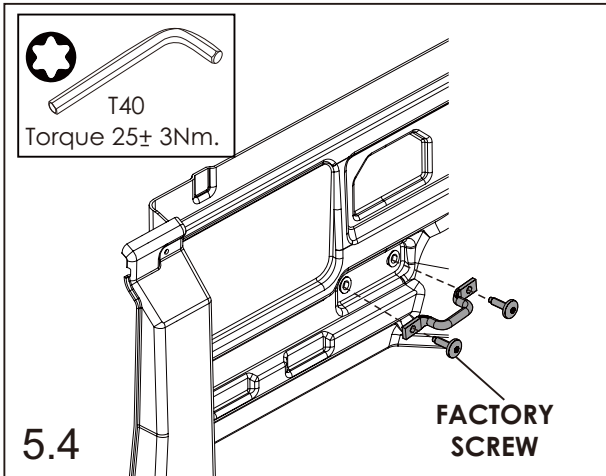
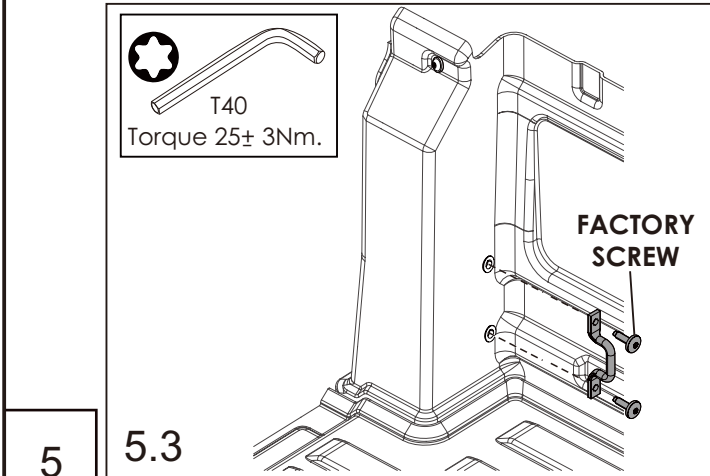
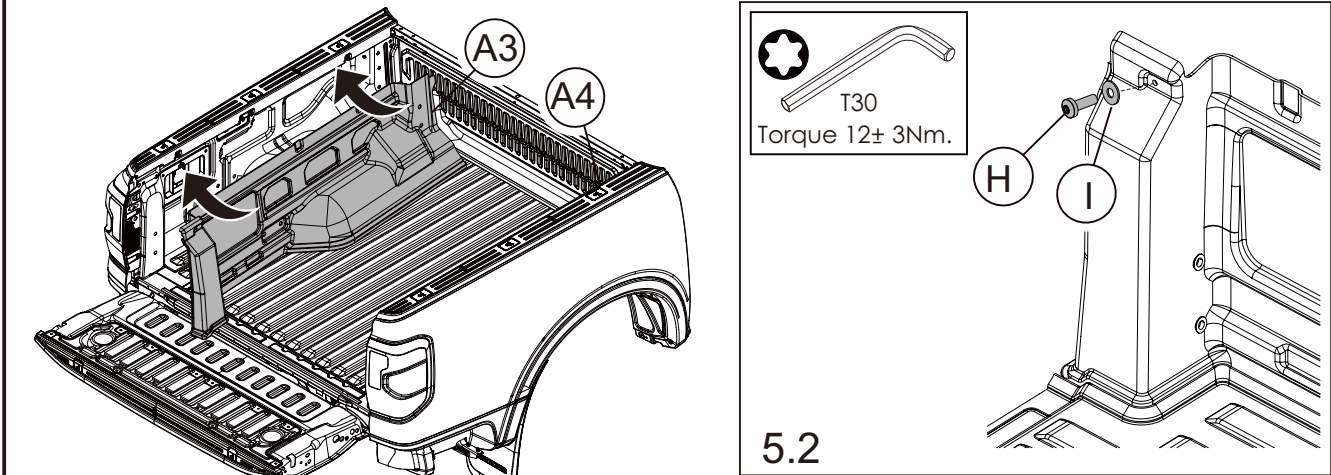
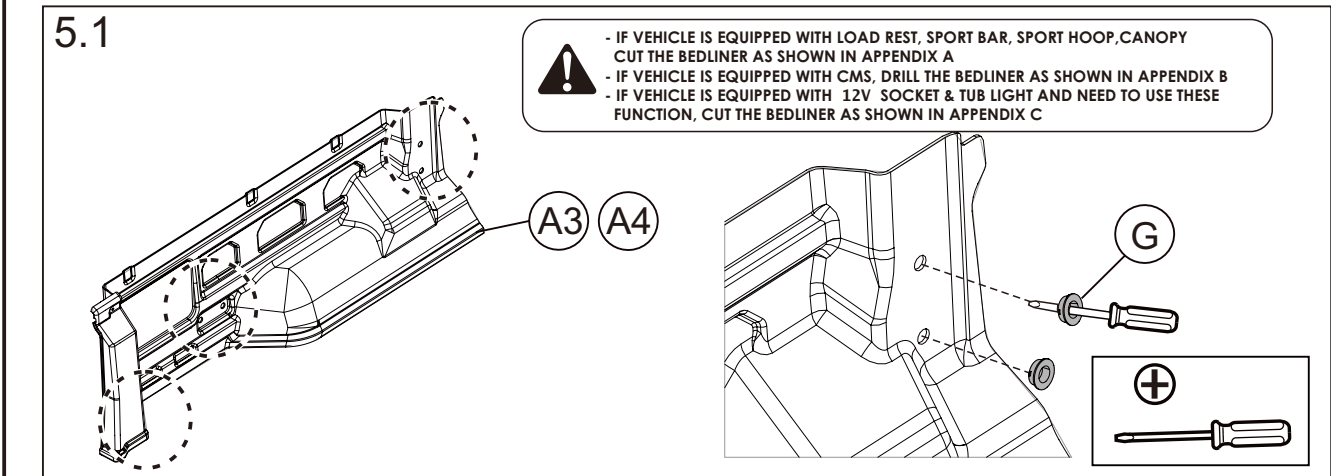
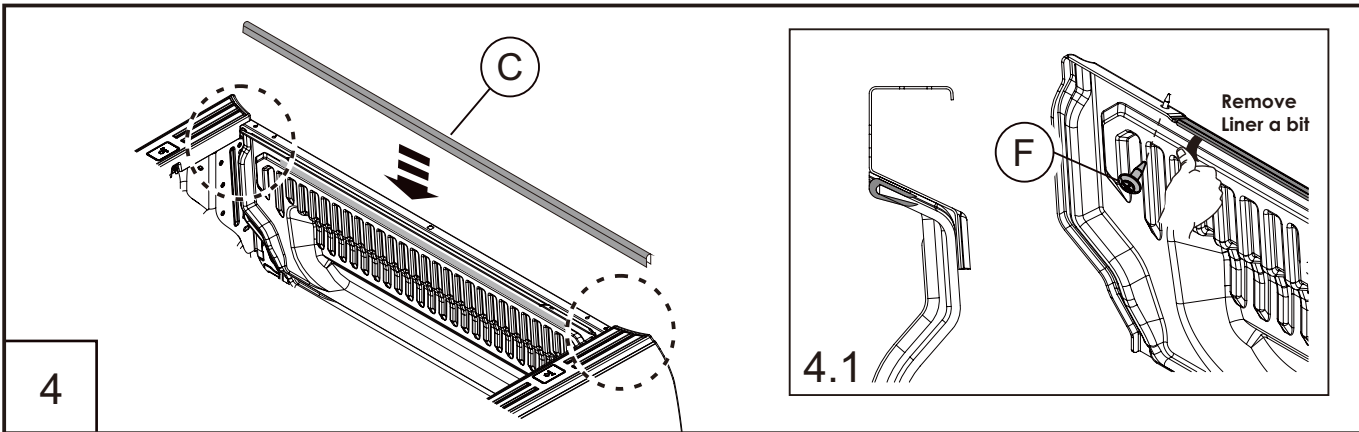

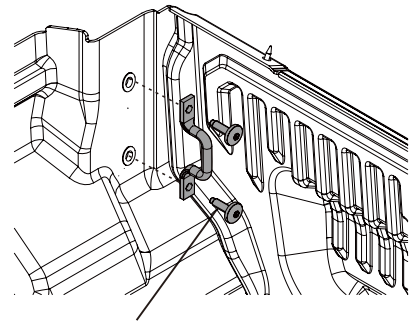
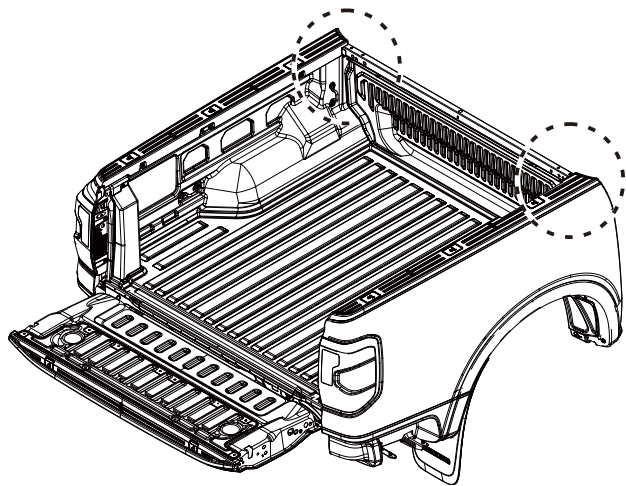

**FACTORY  
SCREW**

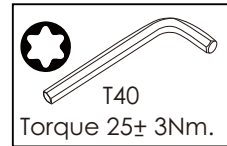

6.1

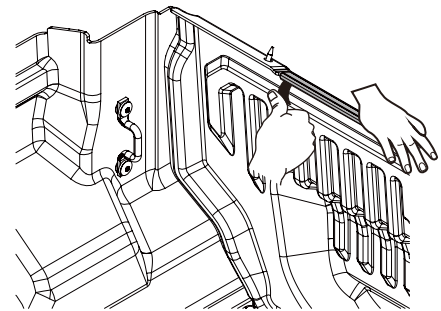

6.2

**!** MUST PRESS DOUBLE SIDE TAPE ATTACH FULLY  
A LONG THE LENGTH.

6

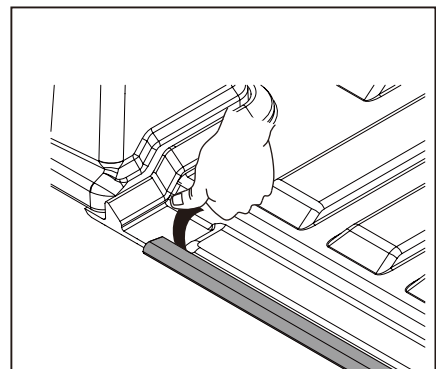
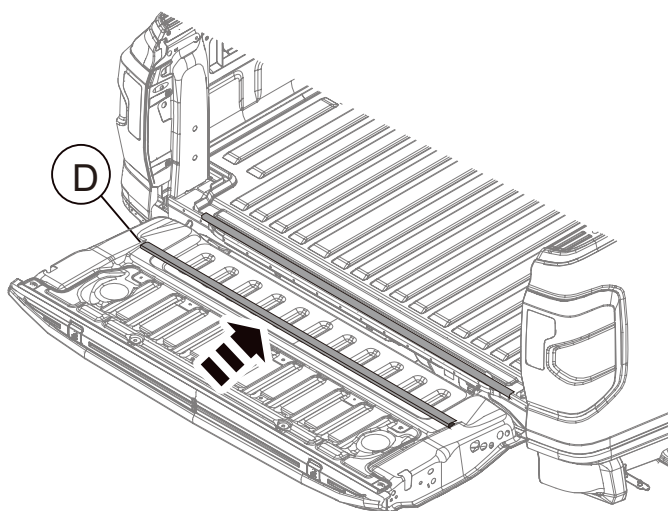

**!** MUST PRESS DOUBLE SIDE TAPE ATTACH FULLY  
A LONG THE LENGTH.

7

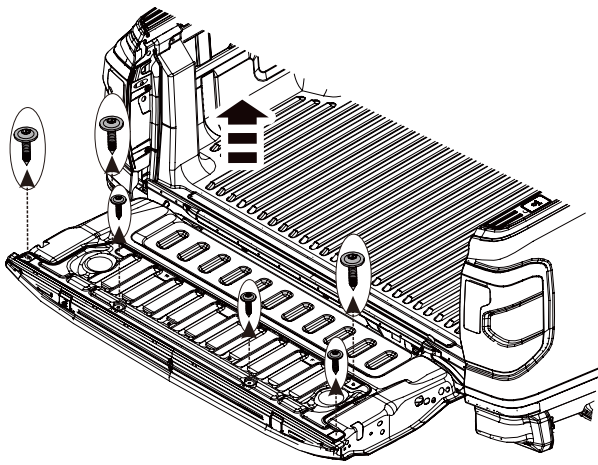

8

**FACTORY**  
Keep for next step

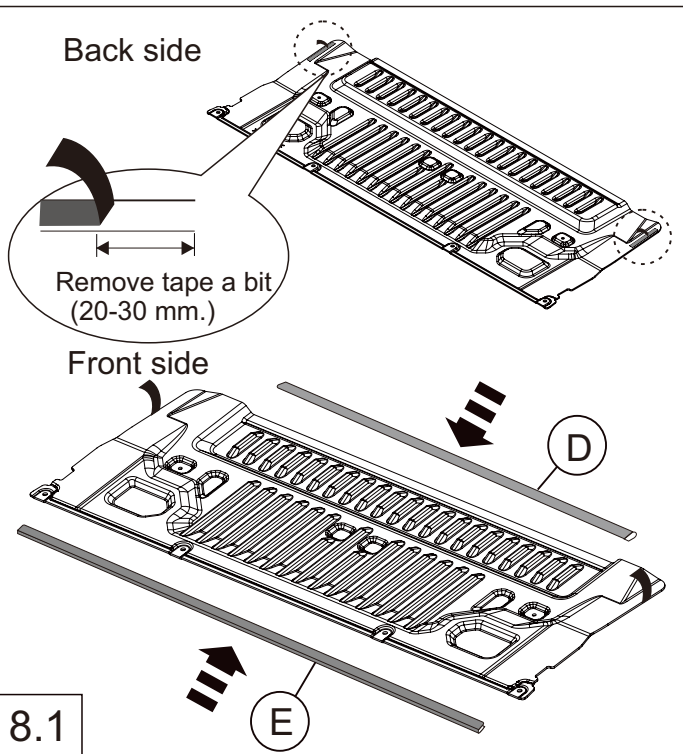
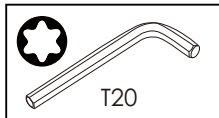

8.1

**!** Ensure bolt holes are aligned before attaching the tape

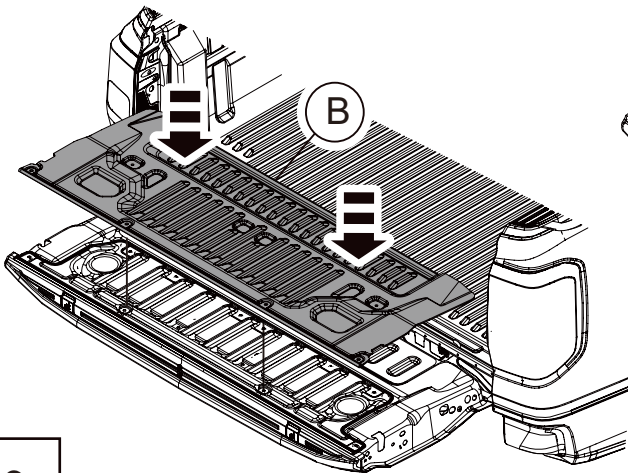

9

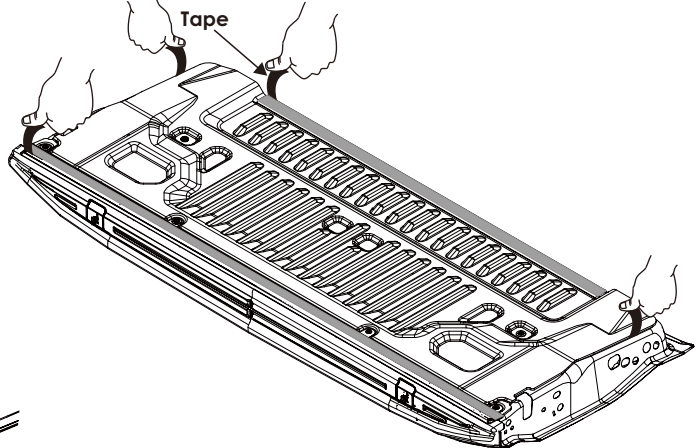

**!** MUST PRESS DOUBLE SIDE TAPE ATTACH FULLY A LONG THE LENGTH.

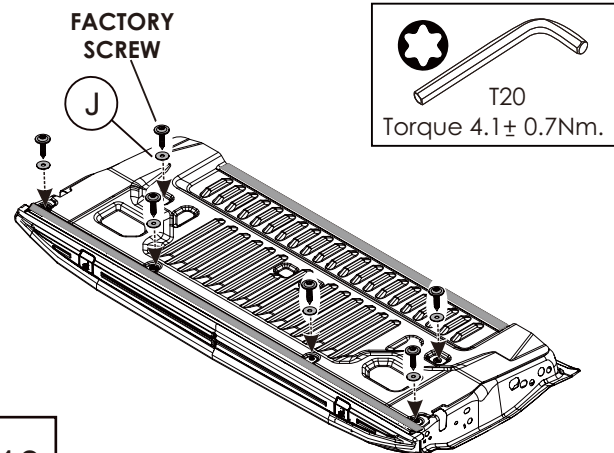

10

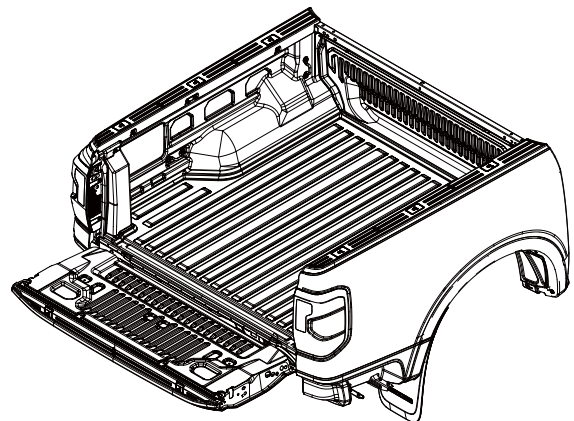

11

**!** DON'T WASH THE CAR AFTER BEDLINER INSTALL 24 Hr.

Cut the bedliner on both front LH and RH corners along the Trim line if the vehicle is equipped with OE Load rest, Sport Bar, Sport Hoop

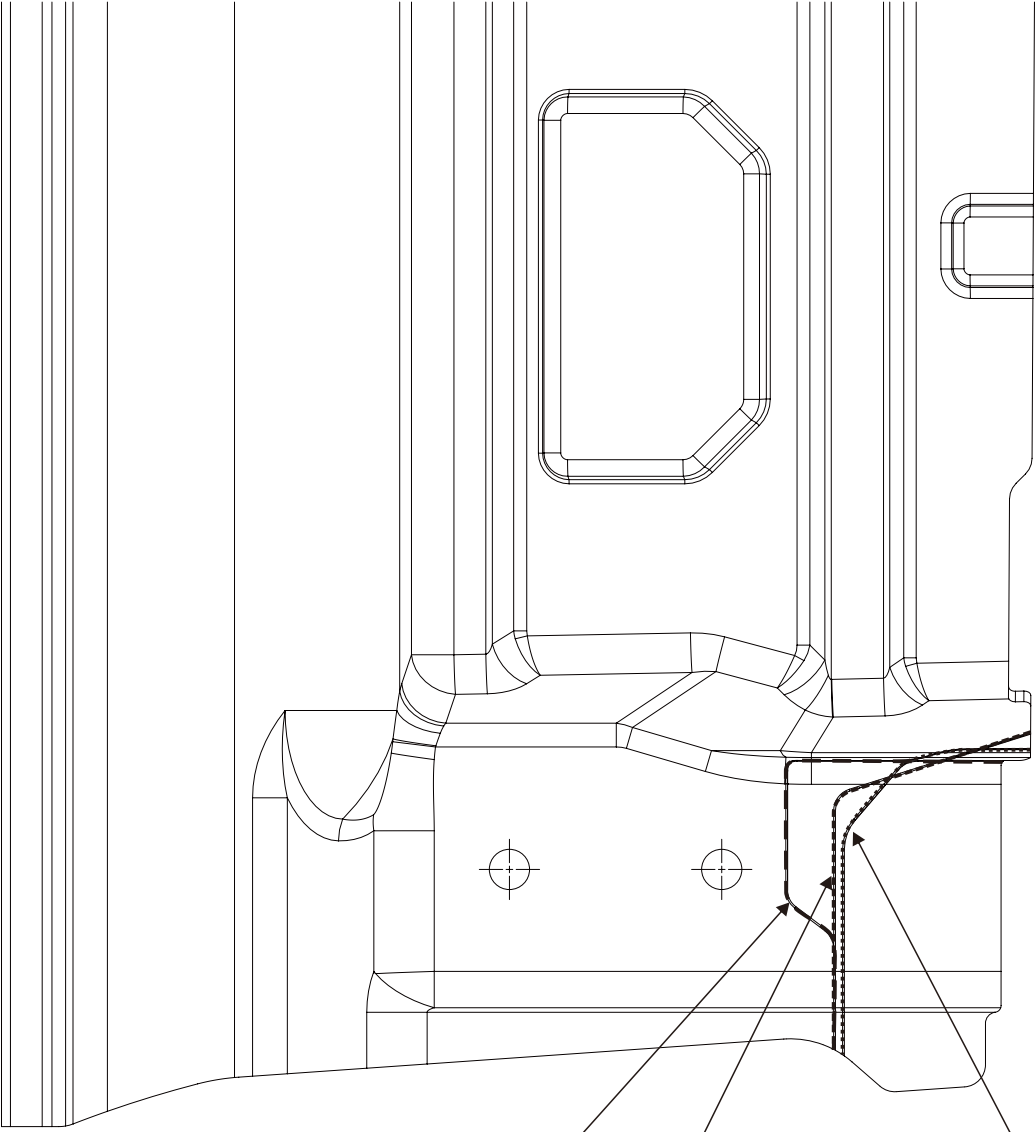

Trim line for Load Rest

Trim line for Sport Hoop,  
Aeroklas FLA Canopy

Trim line for Sport Bar

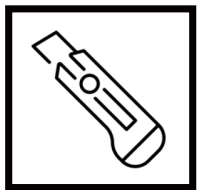
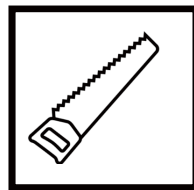

**LHS**

DRILL THE BEDLINER ON BOTH FRONT AND REAR OF LHS PANEL, IF THE VEHICLE IS EQUIPPED WITH OE CMS.

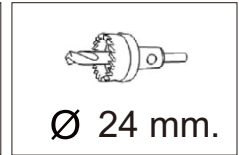
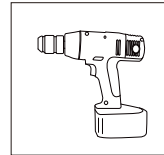

MOLD MARKING POSITION FOR CMS

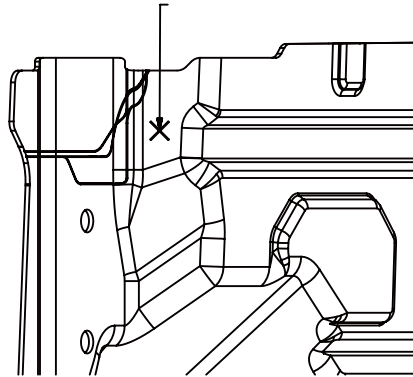

FRONT ZONE (SIDE VIEW)

MOLD MARKING POSITION FOR CMS

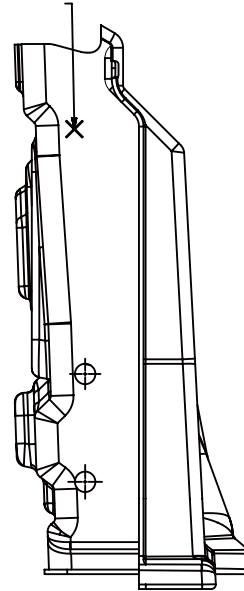

REAR ZONE (BACK VIEW)

**RHS**

DRILL THE BEDLINER ON BOTH FRONT AND REAR OF RHS PANEL, IF THE VEHICLE IS EQUIPPED WITH OE CMS.

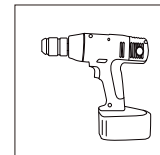

MOLD MARKING POSITION FOR CMS

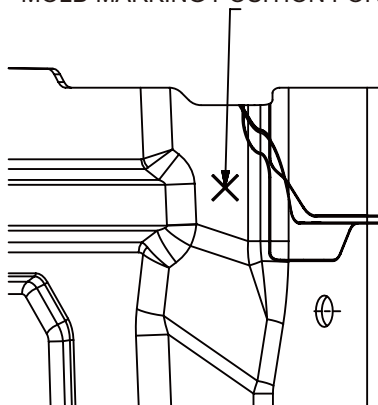

FRONT ZONE (SIDE VIEW)

MOLD MARKING POSITION FOR CMS

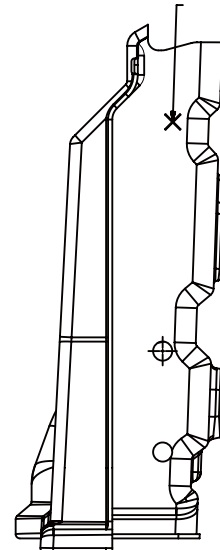

REAR ZONE (BACK VIEW)

LHS

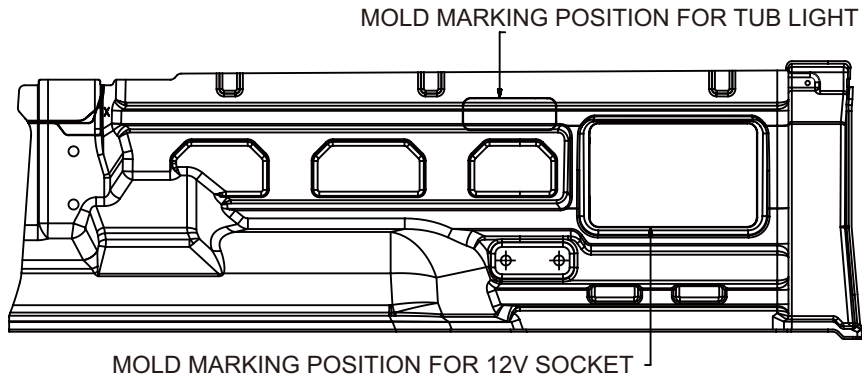

RHS

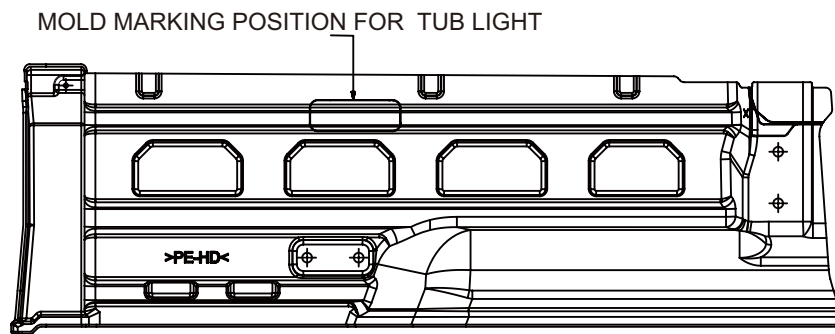

**CAUTION:** IN CASE THAT BEDLINER PARTS ARE FOUND TO SHRINK DUE TO WEATHER CONDITIONS OR PART DEFORMATION, EXPOSE THE PARTS TO SUNLIGHT FOR MORE THAN 10 MINUTES OR USE A HOT AIR BLOWER ON THE BACK OF PARTS

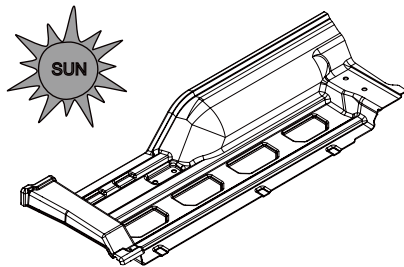

EXPOSE TO SUNLIGHT FOR 10 MINUTES OR MORE TO LENGTHEN THE BEDLINER PARTS

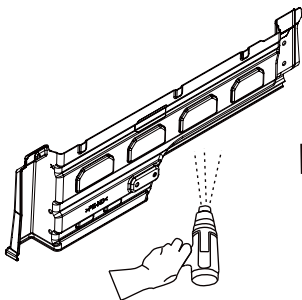

USE A HOT AIR BLOWER ON THE BACK OF PARTS

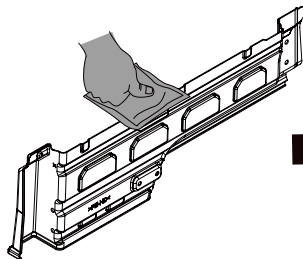

PRESS BY WET CLOTH

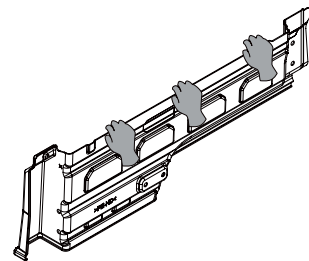

KNEAD BY HAND